

## Foreword

- (a) The Civil Aviation Requirements for Air Operator Certificate Holders - JCAR OPS 1 have been issued by Jordan Civil Aviation Regulatory under the provisions of Jordan Civil Aviation Law.
- (b) ICAO Annex 6 has been used to provide the basic structure of JCAR OPS 1, Commercial Air Transportation (Airplane). The content of Annex 6 has been used and added to where necessary by making use of existing European regulations (EU OPS).
- (c) Definitions and abbreviations of terms used in JCAR OPS 1 that are considered generally applicable are contained in General Operating Rules (GOR), Definitions and Abbreviations. However, definitions and abbreviations of terms used in JCAR OPS 1 that are specific to a Subpart of JCAR OPS 1 are normally given in the Subpart concerned or, exceptionally, in the associated compliance or interpretative material.
- (d) JCAR OPS 1 is based on the EU-OPS 1 amendment 2 and the same paragraph numbering has been used for easy reference purposes.
- (e) Section 2 of the JCAR OPS 1 contains Acceptable Means of Compliance, Advisory Circulars and Interpretative / Explanatory Material that has been agreed for inclusion in JCAR OPS 1.
  - (1) Where a particular JCAR paragraph does not have an Acceptable Means of Compliance, Advisory Circulars and or any Interpretative/Explanatory Material, it is considered that no supplementary material is required.
  - (2) A numbering system has been used in which the Acceptable Means of Compliance Advisory Circulars and Interpretative / Explanatory Material uses the same number as the JCAR OPS 1 paragraph to which it refers. The number is introduced by the letters AMC, AC or IEM to distinguish the material from the JCAR itself.
  - (3) The acronyms AMC, AC and IEM also indicate the nature of the material and for this purpose the three types of material are defined as follows:
    - Acceptable Means of Compliance (AMC) illustrate a means, or several alternative means, but not necessarily the only possible means by which a requirement can be met.

- Advisory Circulars (AC) are non-requirements that are provided as interpretations, explanations and / or acceptable means of compliance.
  - Interpretative / Explanatory Material (IEM) helps to illustrate the meaning of requirements.
- (f) New, amended and corrected text will be marked with a vertical bar to the left until a subsequent Amendment is issued
- (g) The editing practices used in this document are as follows:
- (1) 'Shall' is used to indicate a mandatory requirement and may appear in JCARs.
  - (2) 'Should' is used to indicate a recommendation and normally appears in AMCs and IEMs.
  - (3) 'May' is used to indicate discretion by CARC, the industry or the applicant, as appropriate.
  - (4) 'Will' indicates a mandatory requirement and is used to advise pilots of action incumbent on the Authority

NOTE: The use of the male gender implies the female gender and vice versa

## **JCAR OPS 1 Commercial Air Transport (A)**

### **Table of Contents**

#### **AC/AMC/IEM B**

#### **General**

AC to Appendix 1 to JCAR OPS 1.005(a)	<a href="#">Operations of performance class B airplanes</a>
AMC OPS 1.035	<a href="#">Quality System</a>
IEM OPS 1.035	<a href="#">Quality System – Organization examples</a>
AC OPS 1.037	<a href="#">Accident prevention and flight safety program</a>
AC OPS 1.037(a) (2)	<a href="#">Occurrence Reporting Scheme</a>
AC OPS 1.037(a) (4)	<a href="#">Flight Data Monitoring Program</a>
IEM OPS 1.065	<a href="#">Carriage of weapons of war and munitions of war</a>
IEM OPS 1.070	<a href="#">Carriage of sporting weapons</a>
AC OPS 1.085(e) (3)	<a href="#">Crew responsibilities</a>
AC OPS 1.160(a) (1) and (2)	<a href="#">Preservation of Recordings</a>
AC OPS 1.165(b) (2)	<a href="#">Leasing of airplanes between Jordanian operators</a>
AC OPS 1.165(c) (2)	<a href="#">Leasing of airplanes between Jordanian operator and any entity other than Jordanian operator</a>
Appendix to AC OPS 1.037 (a) (4)	<a href="#">Accident prevention and flight safety program</a>

#### **AC/AMC/IEM C**

#### **Operator Certification & Supervision**

IEM OPS 1.175	<a href="#">The management organization of an AOC holder</a>
IEM OPS 1.175(c) (2)	<a href="#">Principal place of business</a>
AC OPS 1.175(i)	<a href="#">Nominated Post holders – Competence</a>
AC OPS 1.175(j)	<a href="#">Combination of nominated post holder’s responsibilities</a>
AC OPS 1.175(j) & (k)	<a href="#">Employment of staff</a>
IEM OPS 1.185(b)	<a href="#">Maintenance Management Exposition details</a>

#### **AC/AMC/IEM D**

#### **Operational Procedures**

AC OPS 1.195	<a href="#">Operational Control</a>
AC OPS 1.205	<a href="#">Competence of Operations personnel</a>
AMC OPS 1.210(a)	<a href="#">Establishment of procedures</a>
IEM OPS 1.210(b)	<a href="#">Establishment of procedures</a>
AC OPS 1.216	<a href="#">In-flight Operational Instructions</a>
AC to JCAR OPS 1.235	<a href="#">Noise abatement departure procedures (NADP)</a>
AC OPS 1.243	<a href="#">Operations in areas with specified navigation performance requirements IEM OPS 1.245 (a) maximum distances from an adequate aerodrome for two-engine airplanes without ETOPS Approval</a>
AMC OPS 1.245(a) (2)	<a href="#">Operation of non-ETOPS compliant twin turbojet airplanes between 120 and 180 minutes from an adequate aerodrome</a>
IEM OPS 1.250	<a href="#">Establishment of Minimum Flight Altitudes</a>

AC OPS 1.255  
AC OPS 1.260  
AMC OPS 1.270  
AC OPS 1.280  
AC OPS 1.280 IEM  
AC OPS 1.297(b) (2)  
AMC OPS 1.297  
AMC OPS 1.300  
IEM OPS 1.305  
IEM OPS 1.307  
AC OPS 1.308  
AC OPS 1.310(a) (3)  
IEM OPS 1.310(b)  
AC OPS 1.311(b) (i)

AC OPS 1.345  
AC OPS 1.346  
AC OPS 1.390(a) (1)  
AC OPS 1.390(a) (2)  
AC OPS 1.390(a) (3)  
AC OPS 1.398  
IEM OPS 1.400  
Appendix 1 to AMC OPS 1.245(a) (2)

## **AC/AMC/IEM E**

## **All Weather Operations**

AC OPS 1.430  
AMC OPS 1.430(b) (4)  
  
IEM OPS 1.430

AC OPS to Appendix 1 to JCAR-OPS 1.430(d)

IEM to Appendix 1 to JCAR OPS 1.430, paragraphs (f) and (g)

IEM to Appendix 1 to JCAR OPS 1.430, paragraph (g) (5) - Table 8

AC OPS to Appendix 1 to JCAR OPS 1.430(h)  
AC to Appendix 1 to JCAR OPS 1.430, paragraph (j)

AC to Appendix 1 to JCAR OPS 1.440  
IEM to Appendix 1 to JCAR OPS 1.440, paragraph (b)

IEM OPS 1.450(g) (1)

## **AC/AMC/IEM F**

## **Performance General**

AMC OPS 1.475(b)

[Contingency Fuel Statistical Method](#)  
[Carriage of persons with Reduced Mobility](#)  
[Cargo carriage in the passenger cabin](#)  
[Passenger Seating](#)  
[Passenger Seating](#)  
[Planning Minima for Alternate Aerodromes](#)  
[Application of aerodrome forecasts](#)  
[Submission of ATS Flight plan](#)  
[Re/defueling with passengers embarking, on board or disembarking](#)  
[Refueling/Defueling with wide-cut fuel](#)  
[Push Back and Towing](#)  
[Controlled rest on flight deck](#)  
[Cabin crew seating positions](#)  
[Minimum number of cabin crew required to be on board an airplane during disembarkation when the number of passengers remaining on board is less than 20](#)  
[Ice and other contaminants](#)  
[Flight in expected or actual icing conditions](#)  
[Assessment of Cosmic Radiation](#)  
[Working Schedules and Record Keeping](#)  
[Explanatory Information](#)  
[Use of Airborne Avoidance System \(ACAS\)](#)  
[Approach and Landing Conditions](#)  
[Power supply to essential services](#)

[Continuous Descent Final Approach \(CDFA\)](#)  
[Effect on Landing Minima of temporarily failed or downgraded Ground Equipment](#)  
[Documents containing information related to All Weather Operations](#)  
[Aerodrome operating minima Determination of RVR/Visibility Minima for Category I APV and non-precision approaches](#)  
[Establishment of minimum RVR for Category II and III Operations](#)  
[Crew actions in case of autopilot failure at or below decision height in fail-passive Category III operations](#)  
[Aerodrome operating minima Enhanced vision system](#)  
[Terminology: XLS= ILS/MLS/GLS etc Visual Maneuvering \(circling\)](#)  
[Operational Demonstrations](#)  
[Criteria for a successful CAT II/III approach and automatic landing](#)  
[Low Visibility Operations Training & Qualifications](#)

[Landing - Reverse Thrust Credit](#)

IEM OPS 1.475(b)

[Factoring of Automatic Landing Distance Performance Data  
\(Performance Class A Airplanes only\)](#)

## **AC/AMC/IEM G**

## **Performance Class A**

IEM OPS 1.485(b)

[General – Wet and Contaminated Runway data](#)

IEM OPS 1.490(c) (3)

[Take-off – Runway surface condition](#)

IEM OPS 1.490(c) (6)

[Loss of runway length due to alignment](#)

IEM OPS 1.495(a)

[Take-off obstacle clearance](#)

AMC OPS 1.495(c) (4)

[Take-off obstacle clearance](#)

AMC OPS 1.495 (d) (1) & (e) (1)

[Required Navigational Accuracy](#)

IEM OPS 1.495(f)

[Engine failure procedures](#)

AMC OPS 1.500

[En-Route – One Engine Inoperative](#)

IEM OPS 1.510(b) and (c)

[Landing – Destination and Alternate Aerodromes](#)

AMC OPS 1.510 & 1.515

[Landing – Destination and Alternate Aerodromes Landing -](#)

[Dry Runways](#)

IEM OPS 1.515(c)

[Landing – Dry runway](#)

## **AC/AMC/IEM H**

## **Performance Class B**

AMC OPS 1.530(c) (4)

[Take-Off Performance Correction Factors](#)

IEM OPS 1.530(c) (4)

[Take-Off Performance Correction Factors](#)

AMC OPS 1.530(c) (5)

[Runway Slope](#)

IEM OPS 1.535

[Obstacle Clearance in Limited Visibility](#)

AMC OPS 1.535(a)

[Take-off Flight Path Construction](#)

IEM OPS 1.535(a)

[Take-off flight path construction](#)

IEM OPS 1.540

[En-Route](#)

IEM OPS 1.542

[En-route – Single-engine Airplanes](#)

AMC OPS 1.542(a)

[En-Route - Single-engine airplanes](#)

AMC OPS 1.545 & 1.550

[Landing Destination and Alternate Aerodromes Landing - Dry  
runway](#)

AMC OPS 1.550(b) (3)

[Landing Distance Correction Factors](#)

AMC OPS 1.550(b) (4)

[Runway Slope](#)

IEM OPS 1.550(c)

[Landing – Dry Runway](#)

IEM OPS 1.555(a)

[Landing on Wet Grass Runways](#)

## **AC/AMC/IEM I**

## **Performance Class C**

IEM OPS 1.565(d) (3)

[Take-off](#)

IEM OPS 1.565(d) (6)

[Loss of runway length due to alignment](#)

AMC OPS 1.565(d) (4)

[Runway Slope](#)

AMC OPS 1.570(d)

[Take-off Flight Path](#)

AMC OPS 1.570(e) (1) & (f) (1)

[Required navigational accuracy](#)

AMC OPS 1.580

[En-Route – One Engine Inoperative](#)

AMC OPS 1.590 & 1.595

[Landing – Destination and Alternate Aerodromes Landing –](#)

[Dry Runways](#)

AMC OPS 1.595(b) (3)  
AMC OPS 1.595(b) (4)  
IEM OPS 1.595(c)

[Landing Distance Correction Factors](#)  
[Runway Slope](#)  
[Landing Runway](#)

## **AC/AMC/IEM J**

## **Mass & Balance**

IEM OPS 1.605(e)  
AC OPS 1.605  
AMC to Appendix 1 to JCAR OPS 1.605  
IEM to Appendix 1 to JCAR OPS 1.605  
AMC OPS 1.620(a)  
IEM OPS 1.620(d) (2)  
IEM OPS 1.620(g)  
IEM OPS 1.620(h) & (i)  
AMC to Appendix 1 to JCAR OPS 1.620 (g)  
IEM to Appendix 1 to JCAR OPS 1.620 (g)  
IEM to Appendix 1 to JCAR OPS 1.625

[Fuel density](#)  
[Mass values](#)  
[Accuracy of weighing equipment](#)  
[Centre of gravity limits](#)  
[Passenger mass established by use of a verbal statement](#)  
[Holiday Charter](#)  
[Statistical evaluation of passenger and baggage mass data](#)  
[Adjustment of standard masses](#)  
[Guidance on passenger weighing surveys](#)  
[Guidance on passenger weighing surveys](#)  
[Mass and balance documentation](#)

## **AC/AMC/IEM K**

## **Instruments and Equipment**

IEM OPS 1.630  
AMC OPS 1.650/1.652  
IEM OPS 1.650/1.652  
AMC OPS 1.650(i) & 1.652(i)  
IEM OPS 1.650(p)/1.652(s)  
AMC OPS 1.652(d) & (k) (2)  
IEM OPS 1.668  
AC OPS 1.680(a) (2)  
AMC OPS 1.690(b) (6)  
IEM OPS 1.690(b) (7)  
AC OPS 1.700  
AC OPS 1.705/1.710  
AC OPS 1.700, 1.705 and 1.710  
AC OPS 1.715  
AC OPS 1.715(g)  
AC OPS 1.720 and 1.725  
AC OPS 1.715, 1.720 and 1.725  
AC OPS 1.727  
AC OPS 1.730(a) (3)  
AMC OPS 1.745  
AMC OPS 1.755  
IEM OPS 1.760  
IEM OPS 1.770  
AC OPS 1.770 (b) (2) (v)  
  
AMC OPS 1.790  
AMC OPS 1.810  
AC OPS 1.820

[Instruments and Equipment - Approval and Installation](#)  
[Flight and Navigational Instruments and Associated Equipment](#)  
[Flight and Navigational Instruments and Associated Equipment](#)  
[Flight and Navigational Instruments and Associated Equipment](#)  
[Flight and Navigational Instruments and Associated Equipment](#)  
[Headset, boom microphone and associated equipment](#)  
[Flight and Navigational Instruments and Associated Equipment](#)  
[Airborne Collision Avoidance System](#)  
[Quarterly Radiation Sampling](#)  
[Crew member interphone system](#)  
[Crew member interphone system](#)  
[Cockpit Voice Recorders](#)  
[Cockpit Voice Recorders](#)  
[Cockpit Voice Recorders](#)  
[Flight Data Recorders](#)  
[Extensive Modifications of Airplane Systems](#)  
[Flight Data Recorders](#)  
[Flight Data Recorders](#)  
[Combination recorders](#)  
[Seats, seat safety belts, harnesses and child restraint devices](#)  
[First-Aid Kits](#)  
[Emergency Medical Kit](#)  
[First-aid Oxygen](#)  
[Supplemental Oxygen – Pressurized Airplanes](#)  
[Supplemental Oxygen – Pressurized Airplanes \(Not certificated to fly above 25000ft\)](#)  
[Hand Fire Extinguishers](#)  
[Megaphones](#)  
[Emergency Locator Transmitter \(ELT\)](#)

IEM OPS 1.825  
AMC OPS 1.830(b) (2)  
IEM OPS 1.835  
AMC OPS 1.835(c)  
Appendix 1 to AC OPS 1.720/ 1.725

[Life Jackets](#)  
[Life-rafts and ELT for extended overwater flights](#)  
[Survival Equipment](#)  
[Survival Equipment](#)  
[Parameters to be recorded](#)

## **AC/AMC/IEM L**

## **Communication and Navigation Equipment**

IEM OPS 1.845  
AMC OPS 1.865  
AC OPS 1.865(c) (1) (i)  
AC OPS 1.865(e)  
AC OPS 1.865(f)  
AC OPS 1.870  
AC OPS 1.873

[Communications and Navigation Equipment - Approval and Installation](#)  
[Combinations of Instruments and Integrated Flight Systems](#)  
[IFR operations without ADF system](#)  
[FM Immunity Equipment Standards](#)  
[HF - equipment on certain MNPS Routes](#)  
[Additional Navigation Equipment for operations in MNPS Airspace](#)  
[Electronic navigation data management](#)

## **AC/AMC/IEM N**

## **Flight Crew**

AMC OPS 1.940(a)(4)  
AMC OPS 1.945  
IEM OPS 1.945  
AC OPS (AMC) 1.943/ 1.945(a) (9)/ 1.955 (b) (6)/ 1.965(e)  
AC OPS (IEM) 1.943/1.945 (a) (9)/ 1.955 (b) (6)/1.965(e)  
AMC OPS 1.945(a) (9)  
AMC OPS 1.965(c)  
AMC OPS 1.965(d)  
IEM OPS 1.965  
AMC to Appendix 1 to JCAR OPS 1.965  
AMC OPS 1.970  
IEM OPS 1.970(a) (2)  
AMC OPS 1.975  
AC OPS 1.978  
AC to Appendix 1 to JCAR OPS 1.978 (b) (1)  
AC to Appendix 1 to JCAR OPS 1.978 (b) (2)  
AC to Appendix 1 to JCAR OPS 1.978 (b) (3)  
AC to Appendix 1 to JCAR OPS 1.978 (b) (4)  
AC to Appendix 1 to JCAR OPS 1.978 (b) (5)  
AC to Appendix 1 to JCAR OPS 1.978 (b) (6)  
AC to Appendix 1 to JCAR OPS 1.978 (b) (9)  
AC to Appendix 1 to JCAR OPS 1.978 (c) (1) (i)  
AMC OPS 1.980  
AMC OPS 1.980(b)  
  
IEM OPS 1.980(b)  
  
IEM OPS 1.985

[Crewing of inexperienced flight crew members](#)  
[Conversion Course Syllabus](#)  
[Line Flying under Supervision](#)  
[Crew Resource Management \(CRM\)](#)  
[Crew Resource Management \(CRM\)](#)  
[Crew Resource Management - Use of Automation](#)  
[Line checks](#)  
[Emergency and Safety Equipment Training](#)  
[Recurrent training and checking](#)  
[Pilot incapacitation training](#)  
[Recency](#)  
[Co-pilot proficiency](#)  
[Route and aerodrome competence qualification](#)  
[Terminology](#)  
[Requirements, Scope and Documentation of the Program](#)  
[Task Analysis](#)  
[Training Program](#)  
[Training Personnel](#)  
[Feedback Loop](#)  
[Crew Performance Measurement and Evaluation](#)  
[Data Monitoring/Analysis Program](#)  
[Safety Case](#)  
[Operation on more than one type or variant](#)  
[Methodology - Use of Operator Difference Requirement \(ODR\)](#)  
[Tables](#)  
[Operation on more than one type or variant - Philosophy and Criteria](#)  
[Training records](#)

## **AC/AMC/IEM O**

## **Cabin Crew**

IEM OPS 1.988	<a href="#">Additional crew members assigned to specialist duties</a>
IEM OPS 1.990	<a href="#">Numbers and Composition of Cabin Crew</a>
AMC OPS 1.995(a) (2)	<a href="#">Minimum requirements</a>
IEM OPS 1.1000(c)	<a href="#">Senior Cabin Crew Training</a>
AC OPS 1.1005/1.1010/1.1015	<a href="#">Crew Resource Management Training</a>
AMC OPS 1.1012	<a href="#">Familiarization</a>
AC OPS 1.1005/1.1010/ 1.1015/ 1.1020	<a href="#">Representative Training Devices</a>
IEM OPS 1.1015	<a href="#">Recurrent training</a>
AMC OPS 1.1020	<a href="#">Refresher Training</a>
IEM OPS 1.1020(a)	<a href="#">Refresher training</a>
AMC OPS 1.1025	<a href="#">Checking</a>
AC OPS 1.1030	<a href="#">Operation on more than one type or variant</a>
IEM OPS 1.1035	<a href="#">Training records</a>
IEM to Appendix 1 to JCAR OPS 1.1005/ 1.1010/1.1015/1.1020	<a href="#">Crowd Control</a>
IEM to Appendix 1 to JCAR OPS 1.1005/ 1.1010/1.1015/1.1020	<a href="#">Training Methods</a>
IEM to Appendix 1 to JCAR OPS 1.1010/ 1.1015	<a href="#">Conversion and recurrent training</a>

## **AC/AMC/IEM P**

## **Manuals, Logs & Records**

IEM OPS 1.1040(b)	<a href="#">Elements of the Operations Manual subject to approval</a>
IEM OPS 1.1040(c)	<a href="#">Operations Manual - Language</a>
AMC OPS 1.1045	<a href="#">Operations Manual Contents</a>
IEM OPS 1.1045(c)	<a href="#">Operations Manual Structure</a>
IEM OPS 1.1055(a)(12)	<a href="#">Signature or equivalent</a>
IEM OPS 1.1055(b)	<a href="#">Journey log</a>
IEM to Appendix 1 to JCAR OPS 1.1045	<a href="#">Operations Manual Contents</a>

## **AC/AMC/IEM R**

## **Transport of Dangerous Goods by Air**

AC OPS (IEM) 1.1150(a)(5) & (a)(6)	<a href="#">Terminology - Dangerous Goods Accident and Incident Dangerous Goods</a>
AC OPS 1.1160(a)	<a href="#">Medical aid for a patient</a>
AC OPS (IEM) 1.1160(b)	<a href="#">Dangerous goods on an airplane in accordance with the relevant regulations or for operating reasons</a>
AC OPS (IEM) 1.1160 (c)(1)	<a href="#">Scope – Dangerous goods carried by passengers or crew</a>
AC OPS (IEM) 1.1165(b)	<a href="#">Exemption and approval procedures of the technical instructions</a>
AC OPS 1.1215(c)(1)	<a href="#">Information to the commander</a>
AC OPS (AMC) 1.1215(e)	<a href="#">Information in the Event of an in-flight emergency</a>
AC OPS (AMC) 1.1220	<a href="#">Training</a>
AC OPS (AMC) 1.1225	<a href="#">Dangerous Goods Incident and Accident Reports</a>

## **AC/AMC/IEM S**

## **Security**

AC OPS 1.1240	<a href="#">Training Programs</a>
---------------	-----------------------------------



## AC/AMC/IEM B GENERAL

### AC to Appendix 1 to JCAR OPS 1.005 (a) Operations of performance class B airplanes

[See Appendix 1 to JCAR OPS 1.005\(a\)](#)

1. JCAR OPS 1.037 accident prevention and flight safety program.

For operations of performance class B airplanes, a simplified program is sufficient which may consist of the following.

- Collecting case based material (such as accident reports relating to the type of operation) and submit/distribute that information material to the crew members concerned; or
- Collection and use of information from flight safety seminars (such as AOPA flight safety seminars etc)

2. Appendix 2 to JCAR OPS 1.175. The management and organization of an AOC holder.

Supervision. The supervision of personnel may be undertaken by the appropriate nominated post holder(s) subject to time available.

3. JCAR OPS 1.915, Technical Log

Two examples of acceptable ways to fulfill the requirement for a Technical Log are given in attachments 1 and 2 to this AC, where a so called Flight Log is presented. (See attachments)

4. JCAR OPS 1.1070; MME – Maintenance Management Exposition:

The MME can be simplified as relevant to the operation to be conducted.

5. Subpart R; Transport of Dangerous goods by air

- JCAR OPS 1.1145, 1.1155, 1.1160, 1.1165, 1.1215, 1.1220 and 1.1225 are applicable to all operators.

- The requirement in JCAR OPS 1.1165 may be fulfilled by the use of information pamphlets.
- The remainder of this Subpart applies only when the operator Seeks or holds an approval to carry dangerous goods.

6. Subpart S; Security

- JCAR OPS 1.1235. Security requirements in accordance with Jordan national security program applies to the operations covered in this Appendix.
- JCAR OPS 1.1240. Training programs shall be adapted to the kind of operations performed.

7. Appendix 1 to JCAR OPS 1.005(a), subparagraph (a) (3)

Civil twilight ends in the evening when the centre of the sun's disc is 6 degrees below the horizon and begins in the morning when the centre of the sun's disc is 6 degrees below the horizon.

8. JCAR OPS 1.290(b)(2)

Where a Configuration Deviation List (CDL) is provided for airplanes of this size, it is included in the Airplane Flight Manual (AFM) or an equivalent document.

**Attachment 1 to AC to Appendix 1 to JCAR OPS 1.005(a)**

<b>Name of the Operator</b> <sup>1</sup> Address of the operator		<b>Flight Log</b> <sup>2</sup> Commanders signature <sup>4</sup> :			Name of Commander:			Registration:		Sheet No. <sup>3</sup> :	
					Name and duty of other Crew Member(s):			Aeroplane Type:		Date:	

FLIGHT <sup>5</sup>				CHECK	BLOCK TIME			AIRBORNE TIME			LOAD	FUEL ON BOARD			
Nature of Flight <sup>6</sup>	From:	To:	No. of Ldg. <sup>7</sup>	Flight Preparation <sup>8</sup>	Off:	On:	Time:	Take-off:	Ldg.:	Time:	No of Pax/ Cargo (kg/lbs)	Take-off mass: (kg/lbs)	Uplift	Take-off <sup>9</sup> (ltrs/kg/lbs)	Ldg:

<b>FLIGHT DATA BLOCK TIME REPORT</b>				<b>INCIDENTS / OCCURRENCES / OBSERVATIONS REPORT/DEFECTS NOTED</b> <sup>10</sup>									
Total per Day:		Block Time:		Landings:		Mark Type of Report: Operation/ Technical/ Other <sup>11</sup> . Also note any de-/anti-icing as instructed <sup>12</sup>							
Total Previous Report:													
Total to Report:													

<b>FLIGHT DATA FLIGHT TIME REPORT</b>				<b>CERTIFICATE OF RELEASE TO SERVICE</b>			<b>ACTION TAKEN</b> <sup>13</sup>				
Total this sheet:		Flight Time:		Next Maintenance Due:		Name of certifying staff & JAR 145 approval reference (if applicable):					
Total from previous sheet:		Hours		Landings		Certifies that the work specified except as otherwise specified was carried out in accordance with JAR-145 and in respect to that work the aeroplane/aeroplane component is considered ready for release to service.			Signature		
Total to Report:		Date									

- a. Operator’s name and address pre-printed or filled in by hand
- b. Must be filled for each day; and each flight crew
- c. Sheet number (e.g. yy-nn) must be pre-printed or printed by hand. All sheets must be identifiable and numbered according to a continuous system that offers the same security when hand printed as when pre-printed.
- d. The commander’s signature states that everything on this sheet is correct
- e. For flights from A to A, a summary entry may be made. All other flights such as A to B etc., for each flight an entry must be made.
- f. Such as Private, Commercial, Technical, Training, Sailplane towing etc.
- g. Number of landings if summary entry
- h. Flight Preparation according the Operations Manual (commander’s initials) state that:
  - 1. Weight and Balance is within Limit
  - 2. Pre-flight check is done
  - 3. Technical status is checked and airplane accepted by the commander
  - 4. Passengers manifest/documentation performed
- i. Total Fuel on board (state the units unless pre-printed)
- j. Incidents/Occurrences/Observations Report (Operation, Technical, Others): if no report needs to be made state”- NIL -” If a report must be made state (mark) the type of report
- k. Number each observation sequentially for each log sheet.
- l. If de- or anti-icing has been applied, state time and amount and kind of fluid applied or other action taken, e.g. mechanical removal of snow or ice, If oil has been filled, state the time and amount
- m. Use the same number as the corresponding observation to link report and response.

Attachment 2 to AC to Appendix 1 to JCAR OPS 1.005(a)

Address of operator		Date:		CREW		LOAD		OIL		GROUND DE-ICING		Sheet number 00000001			
Name of commander:		Name of commander:		Nb of Pak :		Engine 1 / Engine 2		Type of fluid :		Last release :		Total aeroplane hours : Total aeroplane landing : Next maintenance due : In hours : In landing :			
Registration:		Name and duty of crew member		Mass (kg/lb)		Refilled :		Mixture :		Time of de-icing					
PRE-FLIGHT		BLOCK TIME		AIRBORNE TIME		FUEL ON BOARD (ltrs/kg/lbs)									
Flight Nb :	From :	To :	Nb. of Ldg :	Name / Signature	Off :	On :	Time :	Take-off:	Ldg :	Uplift :	Take-off:	Ldg :			
Defects				Signature				Actions Taken				JAR 145-50 Release to Service			
00000001-1								PN : sn off:				Agreement number: Date: Place: Time: Name: Signature:			
00000001-2								PN : sn off:				Agreement number: Date: Place: Time: Name: Signature:			
00000001-3								PN : sn off:				Agreement number: Date: Place: Time: Name: Signature:			
MEL DEFERRED DEFECT				Captain's Acceptance				Daily check / Maintenance done :				Agreement number: Date: Place: Time: Name: Signature:			
Item MEL	Open Date	Category	Limit Date												

## **AMC OPS 1.035**

### **Quality System**

[See JCAR OPS 1.035](#)

#### 1 Introduction

1.1 In order to show compliance with JCAR OPS 1.035, an operator should establish his Quality System in accordance with the instructions and information contained in the following paragraphs:

#### 2 General

##### 2.1 Terminology

- a. The terms used in the context of the requirement for an operator's Quality System have the following meanings:
  - i. **Accountable Manager.** The person acceptable to CARC who has corporate Authority for ensuring that all operations and maintenance activities can be financed and carried out to the standard required by CARC, and any additional requirements defined by the operator.
  - ii. **Quality Assurance.** All those planned and systematic actions necessary to provide adequate confidence that operational and maintenance practices satisfy given requirements.
  - iii. **Quality Manager.** The manager, acceptable to CARC, responsible for the management of the Quality System, monitoring function and requesting corrective actions

##### 2.2 Quality Policy

2.2.1 An operator should establish a formal written Quality Policy Statement that is a commitment by the Accountable Manager as to what the Quality System is intended to achieve. The Quality Policy should reflect the achievement and continued compliance with JCAR OPS 1 together with any additional standards specified by the operator.

2.2.2 The Accountable Manager is an essential part of the AOC holder's management organization. With regard to the text in JCAR OPS 1.175 (h) and the above terminology, the term 'Accountable Manager' is intended to mean the Chief Executive / President / Managing Director / Director General / General Manager etc. of the operator's organization, who by virtue of his position has overall responsibility (including financial) for managing the organization .

2.2.3 The Accountable Manager will have overall responsibility for the AOC holder's Quality System including the frequency, format and structure of the internal management evaluation activities as prescribed in paragraph 4.9 below.

### 2.3 Purpose of the Quality System

2.3.1 The Quality System should enable the operator to monitor compliance with JCAR OPS 1, the Operations Manual, the Operator's Maintenance Management Exposition, and any other standards specified by that operator, or CARC, to ensure safe operations and airworthy aircraft.

### 2.4 Quality Manager

2.4.1 The function of the Quality Manager to monitor compliance with, and the adequacy of, procedures required to ensure safe operational practices and airworthy airplanes, as required by JCAR OPS 1.035(a), may be carried out by more than one person by means of different, but complementary, Quality Assurance Programs.

2.4.2 The primary role of the Quality Manager is to verify, by monitoring activity in the fields of flight operations, maintenance, crew training and ground operations, that the standards required by CARC, and any additional requirements defined by the operator, are being carried out under the supervision of the relevant Nominated Post holder.

2.4.3 The Quality Manager should be responsible for ensuring that the Quality Assurance Program is properly established, implemented and maintained.

2.4.4 The Quality Manager should:

- a. Have direct access to the Accountable Manager;
- b. Not be one of the nominated post holders; and
- c. Have access to all parts of the operator's and, as necessary, any sub-contractor's organization.

2.4.5 In the case of small/very small operators (See paragraph 7.3 below), the posts of the Accountable Manager and the Quality Manager may be combined. However, in this event, quality audits should be conducted by independent personnel. In accordance with paragraph 2.4.4.b above, it will not be possible for the Accountable Manager to be one of the nominated post holders.

### 3 Quality System

#### 3.1 Introduction

3.1.1 The operator's Quality System should ensure compliance with and adequacy of operational and maintenance activities requirements, standards and operational procedures.

3.1.2 The operator should specify the basic structure of the Quality System applicable to the operation.

3.1.3 The Quality System should be structured according to the size and complexity of the operation to be monitored ('small operators' See also paragraph 7 below).

#### 3.2 Scope

3.2.1 As a minimum, the Quality System should address the following:

- a. The provisions of JCAR OPS 1;
- b. The operator's additional standards and operating procedures;
- c. The operator's Quality Policy;
- d. The operator's organizational structure;
- e. Responsibility for the development, establishment and management of the Quality System;
- f. Documentation, including manuals, reports and records;
- g. Quality Procedures;

- h. Quality Assurance Program;
- i. The required financial, material, and human resources;
- j. Training requirements.

3.2.2 The quality system should include a feedback system to the Accountable Manager to ensure that corrective actions are both identified and promptly addressed. The feedback system should also specify who is required to rectify discrepancies and non-compliance in each particular case, and the procedure to be followed if corrective action is not completed within an appropriate timescale.

### 3.3 Relevant Documentation

3.3.1 Relevant documentation includes the relevant part of the Operations Manual and the Operator's Maintenance Management Exposition, which may be included in a separate Quality Manual.

3.3.2 In addition, relevant documentation should also include the following:

- a. Quality Policy;
- b. Terminology;
- c. Specified operational standards;
- d. A description of the organization;
- e. The allocation of duties and responsibilities;
- f. Operational procedures to ensure regulatory compliance;
- g. Accident Prevention and Flight Safety Program;
- h. The Quality Assurance Program, reflecting;
  - i. Schedule of the monitoring process;
  - ii. Audit procedures;
  - iii. Reporting procedures;
  - iv. Follow-up and corrective action procedures;
  - v. Recording system;
- i. The training syllabus; and
- j. Document control.



## 4 Quality Assurance Program (See JCAR OPS 1.035(b).)

### 4.1 Introduction

4.1.1 The Quality Assurance Program should include all planned and systematic actions necessary to provide confidence that all operations and maintenance are conducted in accordance with all applicable requirements, standards and operational procedures.

4.1.2 When establishing a Quality Assurance Program, consideration should, at least, be given to the paragraphs 4.2 to 4.9 below:

### 4.2 Quality Inspection

4.2.1 The primary purpose of a quality inspection is to observe a particular event / action / document etc., in order to verify whether established operational procedures and requirements are followed during the accomplishment of that event and whether the required standard is achieved.

4.2.2 Typical subject areas for quality inspections are:

- a. Actual flight operations;
- b. Ground De-icing/Anti-icing;
- c. Flight Support Services;
- d. Load Control;
- e. Maintenance;
- f. Technical Standards; and
- g. Training Standards.

### 4.3 Audit

4.3.1 An audit is a systematic and independent comparison of the way in which an operation is being conducted against the way in which the published operational procedures say it should be conducted.

4.3.2 Audits should include at least the following quality procedures and processes:

- a. A statement explaining the scope of the audit;
- b. Planning and preparation;
- c. Gathering and recording evidence; and
- d. Analysis of the evidence.

4.3 Techniques which contribute to an effective audit are:

- a. Interviews or discussions with personnel;
- b. A review of published documents;
- c. The examination of an adequate sample of records;
- d. The witnessing of the activities which make up the operation; and
- e. The preservation of documents and the recording of observations.

4.4 Auditors

4.4.1 An operator should decide, depending on the complexity of the operation, whether to make use of a dedicated audit team or a single auditor. In any event, the auditor or audit team should have relevant operational and/or maintenance experience.

4.4.2 The responsibilities of the auditors should be clearly defined in the relevant documentation.

4.5 Auditor's Independence

4.5.1 Auditors should not have any day-to-day involvement in the area of the operation and/or maintenance activity which is to be audited. An operator may, in addition to using the services of full-time dedicated personnel belonging to a separate quality department, undertake the monitoring of specific areas or activities by the use of part-time auditors. An operator whose structure and size does not justify the establishment of full-time auditors, may undertake the audit function by the use of part-time personnel from within his own organization or from an external source under the terms of an agreement acceptable to CARC. In all cases the operator should develop suitable procedures to ensure that persons directly responsible for the activities to be audited are not selected as part of the auditing team. Where external auditors are used, it is essential that any external specialist is familiar with the type of operation and/or maintenance conducted by the operator.

4.5.2 The operator's Quality Assurance Program should identify the persons within the company who have the experience, responsibility and Authority to:

- a. Perform quality inspections and audits as part of ongoing Quality Assurance;
- b. Identify and record any concerns or findings, and the evidence necessary to substantiate such concerns or findings;
- c. Initiate or recommend solutions to concerns or findings through designated reporting channels;
- d. Verify the implementation of solutions within specific timescales;
- e. Report directly to the Quality Manager.

#### 4.6 Audit Scope

4.6.1 Operators are required to monitor compliance with the operational procedures they have designed to ensure safe operations, airworthy aircraft and the serviceability of both operational and safety equipment. In doing so they should as a minimum, and where appropriate, monitor:

- a. Organization;
- b. Plans and Company objectives;
- c. Operational Procedures;
- d. Flight Safety;
- e. Operator certification (AOC/Operations specification);
- f. Supervision;
- g. Aircraft Performance;
- h. All Weather Operations;
- i. Communications and Navigational Equipment and Practices;
- j. Mass, Balance and Aircraft Loading;
- k. Instruments and Safety Equipment;
- l. Manuals, Logs, and Records;
- m. Flight and Duty Time Limitations, Rest Requirements, and Scheduling;
- n. Aircraft Maintenance/Operations interface;
- o. Use of the MEL;
- p. Maintenance Programs and Continued Airworthiness;
- q. Airworthiness Directives management;
- r. Maintenance Accomplishment;
- s. Defect Deferral;
- t. Flight Crew;

- u. Cabin Crew;
- v. Dangerous Goods;
- w. Security;
- x. Training.

#### 4.7 Audit Scheduling

- 4.7.1 A Quality Assurance Program should include a defined audit schedule and a periodic review cycle area by area. The schedule should be flexible, and allow unscheduled audits when trends are identified. Follow-up audits should be scheduled when necessary to verify that corrective action was carried out and that it was effective.
- 4.7.2 An operator should establish a schedule of audits to be completed during a specified calendar period. All aspects of the operation should be reviewed within every period of 12 months in accordance with the program unless an extension to the audit period is accepted as explained below. An operator may increase the frequency of audits at his discretion but should not decrease the frequency without the agreement of CARC. It is considered unlikely that an interval between audits greater than 24 months would be acceptable for any audit topic.
- 4.7.3 When an operator defines the audit schedule, significant changes to the management, organization, operation, or technologies should be considered as well as changes to the regulatory requirements.

#### 4.8 Monitoring and Corrective Action

- 4.8.1 The aim of monitoring within the Quality System is primarily to investigate and judge its effectiveness and thereby to ensure that defined policy, operational, and maintenance standards are continuously complied with. Monitoring activity is based upon quality inspections, audits, corrective action and follow-up. The operator should establish and publish a quality procedure to monitor regulatory compliance on a continuing basis. This monitoring activity should be aimed at eliminating the causes of unsatisfactory performance.

- 4.8.2 Any non-compliance identified as a result of monitoring should be communicated to the manager responsible for taking corrective action or, if appropriate, the Accountable Manager. Such non-compliance should be recorded, for the purpose of further investigation, in order to determine the cause and to enable the recommendation of appropriate corrective action.
- 4.8.3 The Quality Assurance Program should include procedures to ensure that corrective actions are taken in response to findings. These quality procedures should monitor such actions to verify their effectiveness and that they have been completed. Organizational responsibility and accountability for the implementation of corrective action resides with the department cited in the report identifying the finding. The Accountable Manager will have the ultimate responsibility for resourcing the corrective action and ensuring, through the Quality Manager, that the corrective action has re-established compliance with the standard required by CARC, and any additional requirements defined by the operator.
- 4.8.4 Corrective action
- a. Subsequent to the quality inspection/audit, the operator should establish:
    - i. The seriousness of any findings and any need for immediate corrective action;
    - ii. The origin of the finding;
    - iii. What corrective actions are required to ensure that the non-compliance does not recur;
    - iv. A schedule for corrective action;
    - v. The identification of individuals or departments responsible for implementing corrective action;
    - vi. Allocation of resources by the Accountable Manager, where appropriate.
- 4.8.5 The Quality Manager should:
- a. Verify that corrective action is taken by the manager responsible in response to any finding of non-compliance;
  - b. Verify that corrective action includes the elements outlined in paragraph 4.8.4 above;
  - c. Monitor the implementation and completion of corrective action;
  - d. Provide management with an independent assessment of corrective action, implementation and completion;
  - e. Evaluate the effectiveness of corrective action through the follow-up process.

## 4.9 Management Evaluation

4.9.1 A management evaluation is a comprehensive, systematic, documented review by the management of the quality system, operational policies and procedures, and should consider:

- a. The results of quality inspections, audits and any other indicators;
- b. The overall effectiveness of the management organization in achieving stated objectives.

4.9.2 A management evaluation should identify and correct trends, and prevent, where possible, future non-conformities. Conclusions and recommendations made as a result of an evaluation should be submitted in writing to the responsible manager for action. The responsible manager should be an individual who has the Authority to resolve issues and take action.

4.9.3 The Accountable Manager should decide upon the frequency, format, and structure of internal management evaluation activities.

## 4.10 Recording

4.10.1 Accurate, complete, and readily accessible records documenting the results of the Quality Assurance Program should be maintained by the operator. Records are essential data to enable an operator to analyze and determine the root causes of non-conformity, so that areas of non-compliance can be identified and addressed.

4.10.2 The following records should be retained for a period of 5 years:

- a. Audit Schedules;
- b. Quality inspection and Audit reports;
- c. Responses to findings;
- d. Corrective action reports;
- e. Follow-up and closure reports; and
- f. Management Evaluation reports.

## 5 Quality Assurance Responsibility for Sub-Contractors

### 5.1 Sub-Contractors

5.1.1 Operators may decide to sub-contract out certain activities to external agencies for the provision of services related to areas such as:

- a. Ground De-icing/Anti-icing;
- b. Maintenance;
- c. Ground handling;
- d. Flight Support (including Performance calculations, flight planning, navigation database and dispatch);
- e. Training;
- f. Manual preparation.

5.1.2 The ultimate responsibility for the product or service provided by the sub-contractor always remains with the operator. A written agreement should exist between the operator and the sub-contractor clearly defining the safety related services and quality to be provided. The sub-contractor's safety related activities relevant to the agreement should be included in the operator's Quality Assurance Program.

5.1.3 The operator should ensure that the sub-contractor has the necessary authorization/approval when required and commands the resources and competence to undertake the task. If the operator requires the sub-contractor to conduct activity which exceeds the sub-contractor's authorization / approval, the operator is responsible for ensuring that the sub-contractor's quality assurance takes account of such additional requirements.

## 6 Quality System Training

### 6.1 General

6.1.1 An operator should establish effective, well planned and resourced quality related briefing for all personnel.

6.1.2 Those responsible for managing the Quality System should receive training covering:

- a. An introduction to the concept of the Quality System;
- b. Quality management;
- c. The concept of Quality Assurance;

- d. Quality manuals;
- e. Audit techniques;
- f. Reporting and recording; and
- g. The way in which the Quality System will function in the company.

6.1.3 Time should be provided to train every individual involved in quality management and for briefing the remainder of the employees. The allocation of time and resources should be governed by the size and complexity of the operation concerned.

## 6.2 Sources of Training

6.2.1 Quality management courses are available from the various National or International Standards Institutions, and an operator should consider whether to offer such courses to those likely to be involved in the management of Quality Systems. Operators with sufficient appropriately qualified staff should consider whether to carry out in-house training.

## 7 Organizations with 20 or less full time employees

### 7.1 Introduction

The requirement to establish and document a Quality System and to employ a Quality Manager applies to all operators. References to large and small operators elsewhere in the requirements are governed by aircraft capacity (i.e more or less than 20 seats) and by mass (greater or less than 10 tones Maximum Take-Off Mass). Such terminology is not relevant when considering the scale of an operation and the Quality System required. In the context of quality systems therefore, operators should be categorized according to the number of full time staff employees.

### 7.2 Scale of Operation

7.2.1 Operators who employ 5 or less full time staff are considered to be 'very small' while those employing between 6 and 20 full time employees are regarded as 'small' operators as far as quality systems are concerned. Full-time in this context means employed for not less than 35 hours per week excluding vacation periods.



7.2.2 Complex quality systems could be inappropriate for small or very small operators and the clerical effort required drawing up manuals and quality procedures for a complex system may stretch their resources. It is therefore accepted that such operators should tailor their quality systems to suit the size and complexity of their operation and allocate resources accordingly.

### 7.3 Quality Systems for small/very small Operators

7.3.1 For small and very small operators it may be appropriate to develop a Quality Assurance Program that employs a checklist. The checklist should have a supporting schedule that requires completion of all checklist items within a specified timescale, together with a statement acknowledging completion of a periodic review by top management. An occasional independent overview of the checklist content and achievement of the Quality Assurance should be undertaken.

7.3.2 The 'small' operator may decide to use internal or external auditors or a combination of the two. In these circumstances it would be acceptable for external specialists and or qualified organizations to perform the quality audits on behalf of the Quality Manager.

7.3.3 If the independent quality audit function is being conducted by external auditors, the audit schedule should be shown in the relevant documentation.

7.3.4 Whatever arrangements are made, the operator retains the ultimate responsibility for the quality system and especially the completion and follow-up of corrective actions.

**IEM OPS 1.035**  
**Quality System-Organization examples**

See JCAR OPS 1.035

The following diagrams illustrate two typical examples of Quality organizations.

- 1. Quality System within the AOC holder’s organization when the AOC holder also holds a JCAR 145 approval.

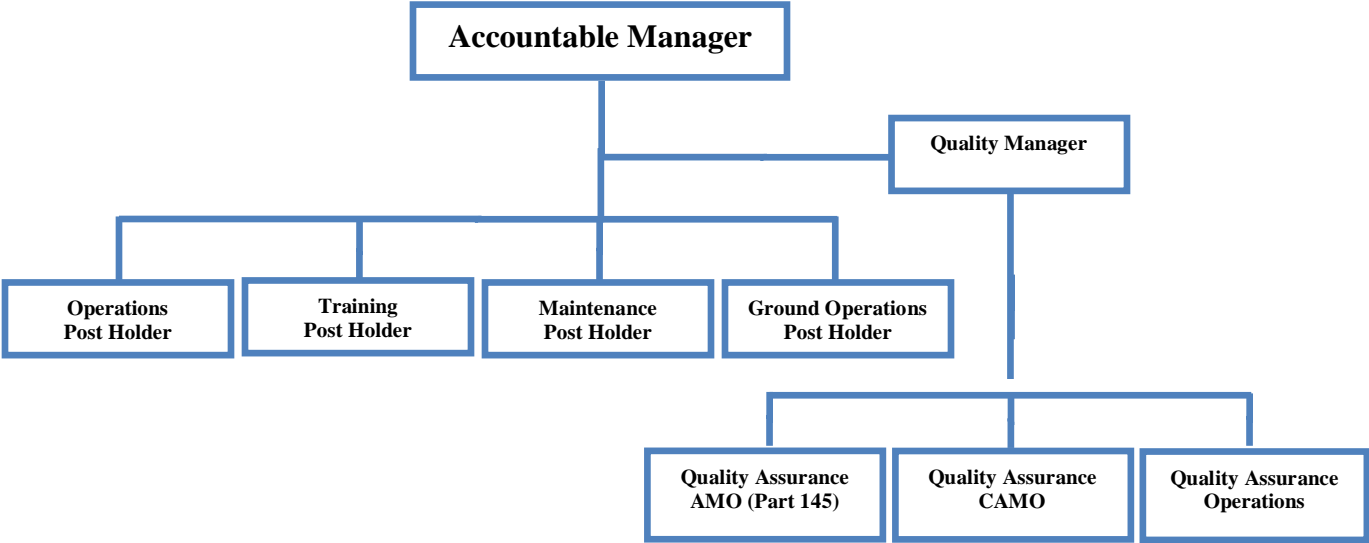

- 2. Quality Systems related to an AOC holder’s organization where aircraft maintenance is contracted out to a JCAR 145 approved organization which is not integrated with the AOC holder:

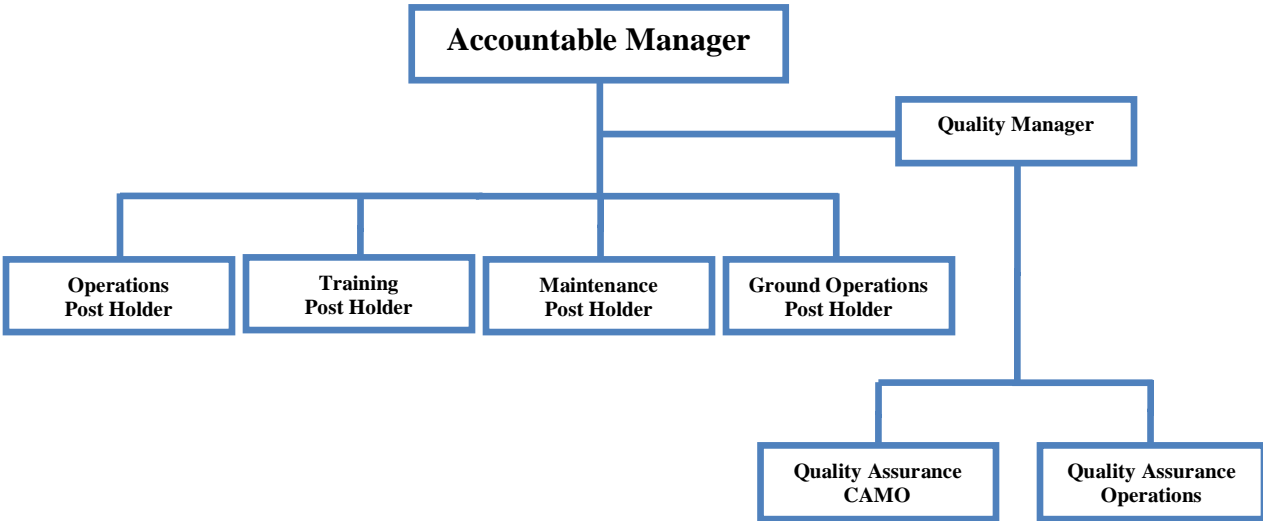

Note. The Quality System and Quality Audit Program of the AOC holder should assure that the maintenance carried out by the JCAR 145 approved organization is in accordance with requirements specified by the AOC holder.

## **AC OPS 1.037**

### **Accident prevention and flight safety program**

(See JCAR OPS 1.037)

1. Guidance material for the establishment of a safety program and Flight Data Monitoring can be found in:
  - a. ICAO Doc 9422 (Accident Prevention Manual); and
  - b. ICAO Doc 9376 (Preparation of an Operational Manual).
  - c. CAP 739 (UK CAA)

## **AC OPS 1.037(a) (2)**

### **Occurrence Reporting Scheme**

See JCAR OPS 1.037(a) (2)

1. The overall objective of the scheme described in JCAR OPS 1.037(a) (2) is to use reported information to improve the level of flight safety and not to attribute blame.
2. The detailed objectives of the scheme are:
  - a. To enable an assessment of the safety implications of each relevant incident and accident to be made, including previous similar occurrences, so that any necessary action can be initiated; and
  - b. To ensure that knowledge of relevant incidents and accidents is disseminated so that other persons and organizations may learn from them.
3. The scheme is an essential part of the overall monitoring function; it is complementary to the normal day to day procedures and 'control' systems and is not intended to duplicate or supersede any of them. The scheme is a tool to identify those occasions where routine procedures have failed. (Occurrences that have to be reported and responsibilities for submitting reports are described in JCAR OPS 1.420.)

4. Occurrences should remain in the database when judged reportable by the person submitting the report as the significance of such reports may only become obvious at a later date.

### **AC OPS 1.037(a) (4)**

#### **Flight Data Monitoring Program**

See JCAR OPS 1.037(a) (4)

1. Flight Data Monitoring (FDM) is the pro-active and non-punitive use of digital flight data from routine operations to improve aviation safety.
2. The manager of the accident prevention and flight safety program, which includes the FDM program, is accountable for the discovery of issues and the transmission of these to the relevant manager(s) responsible for the process (es) concerned. The latter are accountable for taking appropriate and practicable safety action within a reasonable period of time that reflects the severity of the issue.

Note: While an operator may contract the operation of a flight data analysis program to another party the overall responsibility remains with the operator's accident prevention and flight safety program manager.

3. An FDM program will allow an operator to:
  - 3.1 Identify areas of operational risk and quantify current safety margins.
  - 3.2 Identify and quantify operational risks by highlighting when non-standard, unusual or unsafe circumstances occur.
  - 3.3 Use the FDM information on the frequency of occurrence, combined with an estimation of the level of severity, to assess the safety risks and to determine which may become unacceptable if the discovered trend continues.
  - 3.4 Put in place appropriate procedures for remedial action once an unacceptable risk, either actually present or predicted by trending, has been identified.
  - 3.5 Confirm the effectiveness of any remedial action by continued monitoring.

4. Flight Data Monitoring Analysis Techniques:
  - 4.1 Exceedence Detection: This looks for deviations from flight manual limits, and standard operating procedures. A set of core events should be selected to cover the main areas of interest to the operator. A sample list is in the Appendix. The event detection limits should be continuously reviewed to reflect the operator's current operating procedures.
  - 4.2 All Flights Measurement: A system that defines what is normal practice. This may be accomplished by retaining various snapshots of information from each flight.
  - 4.3 Statistics: A series of measures collected to support the analysis process. These would be expected to include the numbers of flights flown and analyzed, aircraft and sector details sufficient to generate rate and trend information.
5. Flight Data Monitoring Analysis, Assessment and Process Control Tools: The effective assessment of information obtained from digital flight data is dependent on the provision of appropriate information technology tool sets. A program suite may include: Annotated data trace displays, engineering unit listings, visualization for the most significant incidents, access to interpretative material, links to other safety information, and statistical presentations.
6. Education and Publication: Sharing safety information is a fundamental principle of aviation safety in helping to reduce accident rates. The operator should pass on the lessons learnt to all relevant personnel and, where appropriate, industry. Similar media to air safety systems may be used. These may include: Newsletters, flight safety magazines, highlighting examples in training and simulator exercises, periodic reports to industry and CARC.
7. Accident and incident data requirements specified in JCAR OPS 1.160 take precedence over the requirements of an FDM program. In these cases the FDR data should be retained as part of the investigation data and may fall outside the de-identification agreements.

8. Every crew member has a responsibility to report events described in JCAR OPS 1.085(b) using the company occurrence reporting scheme detailed in JCAR OPS 1.037(a) (2). Mandatory Occurrence Reporting is a requirement under JCAR OPS 1.420. Significant risk-bearing incidents detected by FDM will therefore normally be the subject of mandatory occurrence reporting by the crew. If this is not the case then they should submit a retrospective report that will be included under the normal accident prevention and flight safety process without prejudice.
9. The data recovery strategy should ensure a sufficiently representative capture of flight information to maintain an overview of operations. Data analysis should be performed sufficiently frequently to enable action to be taken on significant safety issues.
10. The data retention strategy should aim to provide the greatest safety benefits practicable from the available data. A full data set should be retained until the action and review processes are complete; thereafter, a reduced data set relating to closed issues can be maintained for longer term trend analysis. Program managers may wish to retain samples of de-identified full-flight data for various safety purposes (detailed analysis, training, benchmarking etc.).
11. Data Access and Security policy should restrict information access to authorized persons. When data access is required for airworthiness and maintenance purposes, a procedure should be in place to prevent disclosure of crew identity.
12. Procedure Document; this document signed by all parties (airline management, flight crew member representatives nominated either by the union or the flight crew themselves) will, as a minimum, define:
  - a) The aim of the FDM program.
  - b) A data access and security policy that should restrict access to information to specifically authorized persons identified by their position.

- c) The method to obtain de-identified crew feedback on those occasions that require specific flight follow-up for contextual information; where such crew contact is required the authorized person(s) need not necessarily be the program manager, or safety manager, but could be a third party (broker) mutually acceptable to unions or staff and management.
  - d) The data retention policy and accountability including the measures taken to ensure the security of the data.
  - e) The conditions under which, on rare occasions, advisory briefing or remedial training should take place; this should always be carried out in a constructive and non-punitive manner.
  - f) The conditions under which the confidentiality may be withdrawn for reasons of gross negligence or significant continuing safety concern.
  - g) The participation of flight crew member representative(s) in the assessment of the data, the action and review process and the consideration of recommendations.
  - h) The policy for publishing the findings resulting from FDM.
13. Airborne systems and equipment used to obtain FDM data will range from an already installed full Quick Access Recorder, in a modern aircraft with digital systems, to a basic crash protected recorder in an older or less sophisticated aircraft. The analysis potential of the reduced data set available in the latter case may reduce the safety benefits obtainable. The operator shall ensure that FDM use does not adversely affect the serviceability of equipment required for accident investigation.

### **IEM OPS 1.065**

#### **Carriage of weapons of war and munitions of war**

See JCAR OPS 1.065

1. There is no internationally agreed definition of weapons of war and munitions of war. Some States may have defined them for their particular purposes or for national need.

2. It should be the responsibility of the operator to check, with the State(s) concerned, whether or not a particular weapon or munitions is regarded as a weapon of war or munitions of war. In this context, States which may be concerned with granting approvals for the carriage of weapons of war or munitions of war are those of origin, transit, over flight and destination of the consignment and CARC.
3. Where weapons of war or munitions of war are also dangerous goods by definition (e.g. torpedoes, bombs, etc.), Subpart R will also apply. (See also IEM OPS 1.070.)

## **IEM OPS 1.070**

### **Carriage of sporting weapons**

See JCAR OPS 1.070

1. There is no internationally agreed definition of sporting weapons. In general they may be any weapon which is not a weapon of war or munitions of war (See IEM OPS 1.065). Sporting weapons include hunting knives, bows and other similar articles. An antique weapon, which at one time may have been a weapon of war or munitions of war, such as a musket, may now be regarded as a sporting weapon.
2. A firearm is any gun, rifle or pistol which fires a projectile.
3. In the absence of a specific definition, for the purpose of JCAR OPS 1 and in order to provide some guidance to operators, the following firearms are generally regarded as being sporting weapons:
  - a. Those designed for shooting game, birds and other animals;
  - b. Those used for target shooting, clay-pigeon shooting and competition shooting, providing the weapons are not those on standard issue to military forces;
  - c. Air guns, dart guns, starting pistols, etc.
4. A firearm, which is not a weapon of war or munitions of war, should be treated as a sporting weapon for the purposes of its carriage on an airplane.



5. Other procedures for the carriage of sporting weapons may need to be considered if the airplane does not have a separate compartment in which the weapons can be stowed. These procedures should take into account the nature of the flight, its origin and destination, and the possibility of unlawful interference. As far as possible, the weapons should be stowed so they are not immediately accessible to the passengers (e.g. in locked boxes, in checked baggage which is stowed under other baggage or under fixed netting). If procedures other than those in JCAR OPS 1.070(b) (1) are applied, the commander should be notified accordingly.

### **AC OPS 1.085(e) (3)**

#### **Crew responsibilities**

See JCAR OPS 1.085(e) (3)

Information on the effects of medication, drugs, other treatments and alcohol, is to be found in JCAR FCL 3 Medical, IEM FCL 3.040.

### **AC OPS 1.160(a) (1) and (2)**

#### **Preservation of Recordings**

See JCAR OPS 1.060(a) (1) and (2)

In JCAR OPS 1.160(a) (1) and (2), the phrase ‘to the extent possible’ means that either:

1. There may be technical reasons why all of the data cannot be preserved; or
2. The airplane may have been dispatched with unserviceable recording equipment as permitted by the MEL Policy.

### **AC OPS 1.165(c) (2)**

#### **Leasing of airplanes between Jordanian operators**

See JCAR OPS 1.165(c) (2)

1. Approval for a Jordanian operator to wet lease-in a replacement airplane from another Jordanian operator when the need is immediate, unforeseen and urgent may be given in anticipation by CARC in accordance with the method described below.

2. CARC may issue a general approval that allows the lesSee to use a replacement airplane supplied by another Jordanian operator provided that:
  - (a) The routes intended to be flown are contained within the authorized areas of operations specified in the AOC of the lessor; and
  - (b) The lease period does not exceed five consecutive days; and
  - (c) For the duration of the lease, the flight and duty time limitations and rest requirements used by the lessor are not more permissive than apply in lesSee operations manual.

### **AC OPS 1.165(d) (2)**

#### **Leasing of airplanes between Jordanian operator and any entity other than Jordanian operator**

See JCAR OPS 1.165(d) (2)

1. Approval for Jordanian operator to wet lease-in a replacement airplane from an operator other than Jordanian operator to cater for situations in which the need is immediate, unforeseen and urgent may be given in anticipation by CARC in accordance with the method described below. The lesSee should maintain a record of occasions when lessors are used, for inspection by the State that issued his AOC.
2. CARC may approve non- Jordanian operators whose names should then be placed in a list maintained by the lesSee provided that:
  - (a) The lessor is an operator holding an AOC issued by a State which is a signatory to the Convention on International Civil Aviation; and
  - (b) Unless otherwise agreed by CARC, the lesSee audits the operation of the lessor to confirm compliance with operating and aircrew training standards equivalent to JCAR OPS 1, maintenance standards equivalent to JCAR 145, and aircraft certification standards as prescribed in JCAR, and
  - (c) The routes intended to be flown are contained within the authorized areas of operations specified in the AOC of the lessor; and

- (d) The lease period does not exceed five consecutive days; and
- (e) For the duration of the lease, the flight and duty time limitations and rest requirements used by the lessor are not more permissive than apply in the State of the lesSee.

3 Lessors, when first approved by CARC, and any revalidations, remain valid for a period not exceeding 12 months

Note 1. The lesSee is responsible for providing information to CARC to support the initial application and any revalidations.

## Appendix to AC OPS 1.037 (a) (4)

The following table provides examples of FDM events that may be further developed using operator and airplane specific limits. The table is considered illustrative and not exhaustive

<b>Event Group</b>	<b>Description</b>
Rejected take-Off	High Speed Rejected take-off
Take-off Pitch	Pitch rate high on take-off
	Pitch attitude high during take-off
Un stick Speeds	Un stick speed high
	Un stick speed low
Height Loss in Climb-out	Initial climb height loss 20 ft AGL to 400 ft AAL
	Initial climb height loss 400 ft to 1 500 ft AAL
Slow Climb-out	Excessive time to 1 000 ft AAL after take-off
Climb-out Speeds	Climb out speed high below 400 ft AAL
	Climb out speed high 400 ft AAL to 1 000 ft AAL
	Climb out speed low 35 ft AGL to 400 ft AAL
	Climb out speed low 400 ft AAL to 1 500 ft AAL
High Rate of Descent	High rate of descent below 2 000 ft AGL
Go-around	Go-around below 1 000 ft AAL
	Go-around above 1 000 ft AAL
Low Approach	Low on approach
Glide slope	Deviation under glide slope
	Deviation above glide slope (below 600 ft AGL)
Approach Power	Low power on approach
Approach Speeds	Approach speed high within 90 sec of touchdown
	Approach speed high below 500 ft AAL
	Approach speed high below 50 ft AGL
	Approach speed low within 2 minutes of touchdown
Landing Flap	Late land flap (not in position below 500 ft AAL)
	Reduced flap landing
	Flap load relief system operation
Landing Pitch	Pitch attitude high on landing
	Pitch attitude low on landing
Bank Angles	Excessive bank below 100 ft AGL
	Excessive bank 100 ft AGL to 500 ft AAL
	Excessive bank above 500 ft AGL
	Excessive bank near ground (below 20 ft AGL)
Normal Acceleration	High normal acceleration on ground
	High normal acceleration in flight flaps up (+/- increment)
	High normal acceleration in flight flaps down(+/- increment)
	High normal acceleration at landing
Abnormal Configuration	Take-off configuration warning
	Early configuration change after take-off (flap)
	Speed brake with flap
	Speed brake on approach below 800 ft AAL
	Speed brake not armed below 800 ft AAL
Ground Proximity Warning	GPWS operation - hard warning
	GPWS operation - soft warning
	GPWS operation - wind shear warning
	GPWS operation - false warning
TCAS Warning	TCAS operation – Resolution Advisory
Margin to Stall/Buffer	Stick shake
	False stick shake
	Reduced lift margin except near ground
	Reduced lift margin at take-off
	Low buffet margin (above 20 000 ft)
Flight Manual Limitations	Vmo exceedence
	Mmo exceedence
	Flap placard speed exceedence
	Gear down speed exceedence
	Gear selection up/down speed exceedence
	Flap/ Slat altitude exceedence
	Maximum operating altitude exceedence

## **AC/AMC/IEM C**

### **Operator Certification & Supervision**

#### **IEM OPS 1.175**

#### **The management organization of an AOC holder**

See JCAR OPS 1.175(g)-(o)

#### 1 Function and Purpose

1.1 The safe conduct of air operations is achieved by an operator and CARC working in harmony towards a common aim. The functions of the two bodies are different, well defined, but complementary. In essence, the operator complies with the standards set through putting in place a sound and competent management structure. CARC working within a framework of law (statutes) sets and monitors the standards expected from operators.

#### 2 Responsibilities of Management

2.1 The responsibilities of management related to JCAR OPS 1 should include at least the following five main functions:

- a. Determination of the operator's flight safety policy;
- b. Allocation of responsibilities and duties and issuing instructions to individuals, sufficient for implementation of company policy and the maintenance of safety standards;
- c. Monitoring of flight safety standards;
- d. Recording and analysis of any deviations from company standards and ensuring corrective action;
- e. Evaluating the safety record of the company in order to avoid the development of undesirable trends.

## **IEM OPS 1.175(c) (2)**

### **Principal place of business**

See JCAR OPS 1.175(c) (2)

1. JCAR OPS 1.175(c) (2) requires an operator to have his principal place of business located in Jordan.
2. In order to ensure proper jurisdiction over the operator, the term ‘principal place of business’ is interpreted as meaning the State in which the administrative headquarters and the operator’s financial, operational and maintenance management are based.

## **AC OPS 1.175(i)**

### **Nominated Post holders – Competence**

See JCAR OPS 1.175(i)

1. **General.** Nominated Post holders should, in the normal way, is expected to satisfy CARC that they possess the appropriate experience and licensing requirements which are listed in paragraphs 2 to 6 below. In particular cases, and exceptionally, CARC may accept a nomination which does not meet the requirements in full but, in this circumstance, the nominee should be able to demonstrate experience which CARC will accept as being comparable and also the ability to perform effectively the functions associated with the post and with the scale of the operation.
2. Nominated post holders should have:
  - 2.1 Practical experience and expertise in the application of aviation safety standards and safe operating practices;
  - 2.2 Comprehensive knowledge of:
    - a. JCAR OPS 1 and any associated requirements and procedures;
    - b. The AOC holder's Operations Specifications;
    - c. The need for, and content of, the relevant parts of the AOC holder's Operations Manual;
  - 2.3 Familiarity with Quality Systems;
  - 2.4 Appropriate management experience in a comparable organization; and

- 2.5 Five years relevant work experience of which at least two years should be from the aeronautical industry in an appropriate position.
3. Flight operations. The nominated person should hold or have held a valid Airline Transport Pilot License as a pilot in command and the associated ratings appropriate to a type of operation conducted under the AOC. In case the nominated person's Airline Transport Pilot License and ratings are not current, his/her deputy should hold a valid Airline Transport Pilot License as a pilot in command and the associated ratings.
4. Maintenance System. The nominated post holder should possess the following:
  - 4.1 Relevant engineering degree or aircraft maintenance technician with additional education acceptable to CARC. 'Relevant engineering degree' means an engineering degree from Aeronautical, Mechanical, Electrical, Electronic, Avionic or other studies relevant to the maintenance of aircraft/aircraft components.
  - 4.2 Thorough familiarity with the organization's Maintenance Management Exposition.
  - 4.3 Knowledge of the relevant type (s) of aircraft.
  - 4.4 Knowledge of maintenance methods.
5. Crew training. The nominated person and his/her deputy should hold a valid Airline Transport Pilot License as a pilot in command and to be a current type rating instructor on a type operated under the AOC. The nominated person should have a thorough knowledge of the AOC holder's crew training concept for flight, cabin and when relevant other crew
6. Ground Operations. The nominated post holder should have a thorough knowledge of the AOC holder's ground operations concept.

## **AC OPS 1.175(j)**

### **Combination of nominated post holder's responsibilities**

See JCAR OPS 1.175(j)

1. The acceptability of a single person holding several posts, possibly in combination with being the accountable manager as well, will depend upon the nature and scale of the operation. The two main areas of concern are competence and an individual's capacity to meet his responsibilities.
2. As regards competence in the different areas of responsibility, there should not be any difference from the requirements applicable to persons holding only one post.
3. The capacity of an individual to meet his responsibilities will primarily be dependent upon the scale of the operation. However the complexity of the organization or of the operation may prevent, or limit, combinations of posts which may be acceptable in other circumstances.
4. In most circumstances, the responsibilities of a nominated post holder will rest with a single individual. However, in the area of ground operations, it may be acceptable for these responsibilities to be split, provided that the responsibilities of each individual concerned are clearly defined.
5. The intent of JCAR OPS 1.175 is neither to prescribe any specific organizational hierarchy within the operator's organization nor to prevent CARC from requiring a certain hierarchy before it is satisfied that the management organization is suitable.

## **AC OPS 1.175(j) & (k)**

### **Employment of staff**

See JCAR OPS 1.175(j) & (k)

In the context of JCAR OPS 1.175(j) & (k), the expression "full-time staff" means members of staff who are employed for not less than 35 hours per week excluding vacation periods. For the purpose of establishing the scale of operation, administrative staff, not directly involved in operations or maintenance, should be excluded.



## **IEM OPS 1.185(b)**

### **Maintenance Management Exposition details**

See JCAR OPS 1.185(b)

1. The JCAR 145 Organization's Maintenance Management Exposition should reflect the details of any sub-contract(s).
2. A change of airplane type or of the JCAR 145 approved maintenance organization may require the submission of an acceptable amendment to the JCAR 145 Maintenance Management Exposition.

## **AC/AMC/IEM D**

### **Operational Procedures**

#### **AC OPS 1.195**

##### **Operational Control**

See JCAR OPS 1.195

1. Operational control means the exercise by the operator, in the interest of safety, of responsibility for the initiation, continuation, termination or diversion of a flight. There is a requirement for licensed flight dispatchers and a full flight watch system for ETOPS operations.
2. The organization and methods established to exercise operational control should be included in the operations manual and should cover at least a description of responsibilities concerning the initiation, continuation, termination or diversion of each flight.

#### **AC OPS 1.205**

##### **Competence of Operations personnel**

See JCAR OPS 1.205

If an operator employs Flight Operations Officers in conjunction with a method of Operational Control as defined in JCAR OPS 1.195, training for these personnel should be based on relevant parts of ICAO Doc 7192 D3. This training should be described in Subpart D of the Operations Manual.

#### **AMC OPS 1.210(a)**

##### **Establishment of procedures**

See JCAR OPS 1.210(a)

1. An operator should specify the contents of safety briefings for all cabin crew members prior to the commencement of a flight or series of flights.
2. An operator should specify procedures to be followed by cabin crew with respect to:
  - a. Arming and disarming of slides;
  - b. The operation of cabin lights, including emergency lighting;
  - c. The prevention and detection of cabin, oven and toilet fires;
  - d. Action to be taken when turbulence is encountered; and
  - e. Actions to be taken in the event of an emergency and/or an evacuation.

## **IEM OPS 1.210(b)**

### **Establishment of procedures**

See JCAR OPS 1.210(b)

When an operator establishes procedures and a checklist system for use by cabin crew with respect to the airplane cabin, at least the following items should be taken into account:

No	Item	Pre-Takeoff	In-Flight	Pre Landing	Post Landing
1	Brief of cabin crew by the senior cabin crew member prior to commencement of a flight or series of flights	x			
2	Check of safety equipment in accordance with operator's policies and procedures.	x			
3	Security checks as required by Subpart S (JCAR OPS 1.1250).	x			x
4	Supervision of passenger embarkation and disembarkation (JCAR OPS 1.075; JCAR OPS 1.105; JCAR OPS 1.270; JCAR OPS 1.280; JCAR OPS 1.305).	x			x
5	Securing of passenger cabin (e.g. seat belts, cabin cargo/baggage etc. (JCAR OPS 1.280; JCAR OPS 1.285; JCAR OPS 1.310).	x		x	
6	Securing of galleys and stowage of equipment (JCAR OPS 1.325).	x		x	
7	Arming of door slides.	x		x	
8	Safety information to passengers (JCAR OPS 1.285).	x		x	
9	'Cabin secure' report to flight crew.	x	x	x	x
10	Operation of cabin lights	x	If required	x	
11	Cabin crew at crew stations for take-off and landing. (JCAR OPS 1.310, JCAR OPS 1.210(c)/IEM OPS 1.210(c)).	x	If required	x	x
12	Surveillance of passenger cabin.	x	x	x	x
13	Prevention and detection of fire in the cabin (including the combi-cargo area), crew rest areas, galleys and toilets and instructions for actions to be taken.	x	x	x	x
14	Action to be taken when turbulence is encountered or in-flight incidents (pressurization failure, medical emergency etc.). (See also JCAR OPS 1.320 and JCAR OPS 1.325).		x		
15	Disarming of door slides				x
16	Reporting of any deficiency and/or un serviceability of equipment and/or any incident (See also JCAR OPS 1.420).	x	x	x	x

## **AC OPS 1.216**

### **In-flight Operational Instructions**

See JCAR OPS 1.216

When co-ordination with an appropriate Air Traffic Service unit has not been possible, in-flight operational instructions do not relieve a commander of responsibility for obtaining an appropriate clearance from an Air Traffic Service unit, if applicable, before making a change in flight plan.

## **AC JCAR OPS 1.1235**

### **Noise abatement departure procedures (NADP)**

See JCAR OPS 1.235

JCAR OPS 1.235 deals only with the vertical profile of the departure procedures. Lateral track has to comply with the SID.

“Climb profile” in JCAR OPS 1.235(c) means the vertical path of the NADP as it result from the pilots actions (engine power reduction, acceleration, slats/flaps retraction)

“Sequence of action” means the order and the timing in which these pilots action are carried out.

Example: for a given airplane type when establishing the distant NADP, an operator should choose either to reduce power first or then accelerate or to accelerate first and then wait until slats/flaps are retracted before reducing power. The two methods constitute two different sequences of action within the meaning of this AC

For an airplane type, each of the two departure climb profiles should be defined by:

- One sequence of action (one for close in, one for distant)
- Two AAL altitude (heights):
  - The altitude of the first pilot’s action (generally power reduction with or without acceleration). This altitude should not be less than 800 ft AAL
  - The altitude of the end of the noise abatement procedures. This altitude should usually not be more than 300 ft AAL

These two altitudes may be runway specific when the airplane FMS has the relevant function which permits the crew to change thrust reduction and/or acceleration altitude/height.

If the airplane is not FMS equipped or the FMS is not fitted with the relevant function, two fixed heights should be defined and used for each of the two NADPs

## **AC OPS 1.243**

### **Operations in areas with specified navigation performance requirements**

See JCAR OPS 1.243

1. The equipment carriage requirements, operational and contingency procedures and operator approval requirements relating to areas, portions of airspace or on routes where navigation performance requirements have so far been specified can be found in the following documentation:
  - a. For the North Atlantic MNPS - ICAO document Doc 7030/4 Regional Supplementary Procedures (NAT Supps)
  - b. For RVSM in the North Atlantic and Europe (ECAC States) - Doc 7030/4 (NAT and EUR Supps)
  - c. For General Guidance on Required Navigation Performance (RNP) Operations - ICAO Doc 9613
  - d. For European RNAV (ECAC States) - Doc 7030/4 (EUR Supps )
  - e. TGL 2 – B RNAV
  - f. TGL 10 – P RNAV
  - g. Euro control Standard Document 009-93 (RNAV Operations)
2. Operators should be aware that requirements relating to navigation performance parameters, including area navigation (RNAV) and required navigation performance (RNP), are currently under rapid development. Pending the development.

**IEM OPS 1.245(a)**

**Maximum distance from an adequate aerodrome for two-engine airplanes without ETOPS**

**Approval**

See JCAR OPS 1.245

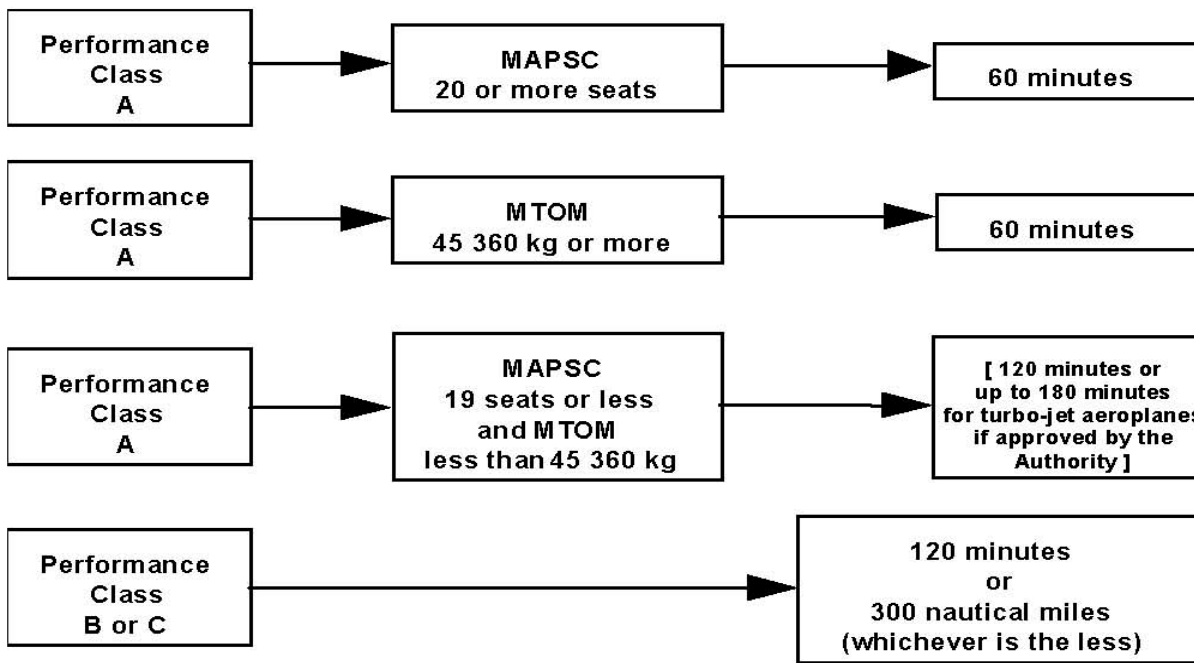

Notes:

1. MAP - Maximum Approved Passenger Seating Configuration
2. MTO - Maximum Take-Off

Mass

## **AMC OPS 1.245(a)(2)**

### **Operation of non-ETOPS compliant twin turbojet airplanes between 120 and 180 minutes from an adequate aerodrome**

See JCAR OPS 1.245(a) (2)

1. As prescribed in JCAR OPS 1.245(a) (2), an operator may not operate a twin turbo-jet powered airplane having a maximum approved passenger seating configuration of 19 or less and a MTOM less than 45360Kg beyond 120 minutes from an adequate aerodrome at the one engine inoperative cruise speed calculated in accordance with JCAR OPS 1.245(b) unless approved by CARC. This 120 minute threshold may be exceeded by no more than 60 minutes. In order for operations between 120 and 180 minutes to be approved, due account should be taken of the airplane's design and capabilities (as outlined below) and an operator's experience related to such operations. An operator should ensure that the following items are addressed. Where necessary, information should be included in the Operations Manual and the Operator's Maintenance Management Exposition.

Note: Mention of "the airplane's design" in paragraph 1 above does not imply any additional Type Design Approval requirements (beyond the applicable original Type Certification requirements) before CARC will permit operations beyond the 120 minute threshold.

2. **Systems capability.** Airplanes should be certificated to JCAR CS 25 as appropriate (or equivalent). With respect to the capability of the airplane systems, the objective is that the airplane is capable of a safe diversion from the maximum diversion distance with particular emphasis on operations with one engine inoperative or with degraded system capability. To this end, the operator should give consideration to the capability of the following systems to support such a diversion:
  - a. Propulsion systems. The airplane power plant should meet the applicable requirements prescribed in JCAR CS 25 and JCAR CS E or equivalents, concerning engine type certification, installation and system operation. In addition to the performance standards established by ARC at the time of engine certification, the engines should comply with all subsequent mandatory safety standards specified by CARC, including those necessary to maintain an acceptable level of reliability. In addition, consideration should be given to the effects of extended duration single engine operation (e.g. the effects of higher power demands such as bleed and electrical).

- b. Airframe systems. With respect to electrical power, three or more reliable (as defined by JCAR CS 25 or equivalent) and independent electrical power sources should be available, each of which should be capable of providing power for all essential services (See Appendix 1). For single engine operations, the remaining power (electrical, hydraulic, pneumatic) should continue to be available at levels necessary to permit continued safe flight and landing, and to provide those services necessary for the overall safety of the passengers and crew. As a minimum, following the failure of any two of the three electrical power sources, the remaining source should be capable of providing power for all of the items necessary for the duration of any diversion. If one or more of the required electrical power sources are provided by an APU, hydraulic system or Air Driven Generator/Ram Air Turbine (ADG/RAT), the following criteria should apply as appropriate:
    - i. To ensure hydraulic power (Hydraulic Motor Generator) reliability, it may be necessary to provide two or more independent energy sources.
    - iii. The ADG/RAT, if fitted, should not require engine dependent power for deployment.
    - iv. The APU should meet the criteria in sub-paragraph c below.
  - c. APU. The APU, if required for extended range operations, should be certificated as an essential APU and should meet the applicable JCAR CS 25 provisions or equivalent.
  - d. Fuel supply system. Consideration should include the capability of the fuel supply system to provide sufficient fuel for the entire diversion taking account of aspects such as fuel boost and fuel transfer.
3. **Power plant Events and corrective action.**
- a. All power plant events and operating hours should be reported by the operator to the Airframe and Engine manufacturers as well as to CARC.



- b. These events should be evaluated by the operator in consultation with CARC and with the engine and airframe manufacturers. CARC may consult with the type design Authority to ensure that world wide data is evaluated.
- c. Where statistical assessment alone may not be applicable eg where the fleet size or accumulated flight hours are small, individual power plant events should be reviewed on a case by case basis.
- d. The evaluation or statistical assessment, when available, may result in corrective action or the application of operational restrictions.

Note. Power plant events could include engine shut downs, both on ground and in flight, (excluding normal training events) including flameout, occurrences where the intended thrust level was not achieved or where crew action was taken to reduce thrust below the normal level for whatever reason, and unscheduled removals.

4. **Maintenance:** The operator's maintenance requirements should address the following:
  - a. Release to service. A pre-departure check, additional to the pre-flight inspection required by JCAR OPS 1.890(a) (1) should be reflected in the Operator's Maintenance Management Exposition. These checks should be conducted and certified by an organization appropriately approved/accepted in accordance with JCAR 145 or by an appropriately trained flight crew member prior to an extended range flight to ensure that all maintenance actions are complete and all fluid levels are at prescribed levels for the flight duration.
  - b. Engine oil consumption programs. Such programs are intended to support engine condition trend monitoring (See below).
  - c. Engine condition trend monitoring program. A program for each power plant that monitors engine performance parameters and trends of degradation that provides for maintenance actions to be undertaken prior to significant performance loss or mechanical failure.

- d. Arrangements to ensure that all corrective actions required by the type design Authority are implemented.
5. **Flight Crew Training:** Flight crew training for this type of operation should include, in addition to the requirements of JCAR OPS 1 Sub part N, particular emphasis on the following:
- a. Fuel management. Verifying required fuel on board prior to departure and monitoring fuel on board en-route including calculation of fuel remaining. Procedures should provide for an independent cross-check of fuel quantity indicators (e.g. fuel flow used to calculate fuel burned compared to indicated fuel remaining). Confirmation that the fuel remaining is sufficient to satisfy the critical fuel reserves.
  - b. Procedures for single and multiple failures in flight that may give rise to go/no-go and diversion decisions - Policy and guidelines to aid the flight crew in the diversion decision making process and the need for constant awareness of the closest suitable alternate aerodrome in terms of time.
  - c. One-engine inoperative performance data. Drift down procedures and one-engine inoperative service ceiling data.
  - d. Weather reports and flight requirements. METAR and TAF reports and obtaining in flight weather updates on en-route alternate, destination and destination alternate aerodromes. Consideration should also be given to forecast winds (including the accuracy of the forecast compared to actual wind experienced during flight) and meteorological conditions along the expected flight path at the one-engine inoperative cruising altitude and throughout the approach and landing.
  - e. Pre-departure check. Flight crew members who are responsible for the pre-departure check of an airplane (See paragraph 3.a above) should be fully trained and competent to do so. The training program required, which should be approved by CARC, should cover all relevant maintenance actions with particular emphasis on checking required fluid levels.

- 6 **MEL.** The MEL should take into account all items specified by the manufacturer relevant to operations in accordance with this AMC.
7. **Dispatch/Flight Planning Requirements.** The operator's dispatch requirements should address the following:
  - a. **Fuel and oil supply.** An airplane should not be dispatched on an extended range flight unless it carries sufficient fuel and oil to comply with the applicable operational requirements and any additional reserves determined in accordance with sub-paragraphs (a) (i) (ii) and (iii) below.
    - (i) **Critical fuel scenario.** The critical point is the furthest point from an alternate aerodrome assuming a simultaneous failure of an engine and the pressurization system. For those airplanes that are type certificated to operate above Flight Level 450, the critical point is the furthest point from an alternate aerodrome assuming an engine failure. The operator should carry additional fuel for the worst case fuel burn condition (one engine vs two engines operating), if this is greater than the additional fuel calculated in accordance with AMC OPS 1.255 1.6a and b, as follows:
      - A. Fly from the critical point to an alternate aerodrome:
        - At 10 000ft; or
        - At 25 000ft or the single-engine ceiling, whichever is lower, provided that all occupants can be supplied with and use supplemental oxygen for the time required to fly from the critical point to an alternate aerodrome; or
        - At the single-engine ceiling, provided that the airplane is type certificated to operate above Flight Level 450.
      - B. Descend and hold at 1 500 feet for 15 minutes in ISA conditions;
      - C. Descend to the applicable MDA/DH followed by a missed approach (taking into account the complete missed approach procedure); followed by
      - D. A normal approach and landing.

- (ii) **Ice protection.** Additional fuel used when operating in icing conditions (e.g. operation of ice protection systems (engine/airframe as applicable)) and, when manufacturer’s data is available, take account of ice accumulation on unprotected surfaces if icing conditions are likely to be encountered during a diversion;
  - (iii) **APU operation.** If an APU has to be used to provide additional electrical power, consideration should be given to the additional fuel required.
- b. **Communication facilities.** The availability of communications facilities in order to allow reliable two-way voice communications between the airplane and the appropriate air traffic control unit at one-engine inoperative cruise altitudes.
- c. Aircraft Technical Log review to ensure proper MEL procedures, deferred items, and required maintenance checks completed.
- d. **En-route alternate aerodrome(s).** Ensuring that en-route alternate aerodromes are available for the intended route, within 180 minutes based upon the one-engine inoperative cruise speed which is a speed within the certificated limits of the airplane, selected by the operator and approved by CARC, and confirmation that, based on the available meteorological information, the weather conditions at en-route alternate aerodromes are at or above the applicable minima for the period of time during which the aerodrome(s) may be used. (See also JCAR OPS 1.297).

**Planning minima**

<b>Planning Minima (RVR visibility required &amp; ceiling if applicable)</b>				
Aerodrome with				
	at least 2 separate approach procedures based on 2 separate aids serving 2 separate runways (See IEM OPS 1.295(c)(1)(ii))	at least 2 separate approach procedures based on 2 separate aids serving 1 runway	or	at least 1 approach procedure based on 1 aid serving 1 runway
Precision Approach Cat II, III (ILS, MLS)	Precision Approach Cat I Minima	Non-Precision Approach Minima		
Precision Approach Cat I (ILS, MLS)	Non-Precision Approach Minima		Circling minima or, if not available, non-precision approach minima plus 200 ft / 1 000 m	
Non-Precision Approach	The lower of non-precision approach minima plus 200 ft / 1 000 m or circling minima	The higher of circling minima or non-precision approach minima plus 200 ft / 1 000 m		
Circling Approach	Circling minima			

## **IEM OPS 1.250**

### **Establishment of Minimum Flight Altitudes**

See JCAR OPS 1.250

1. The following are examples of some of the methods available for calculating minimum flight altitudes.
2. KSS Formula
  - 2.1 Minimum obstacle clearance altitude (MOCA). MOCA is the sum of:
    - i. The maximum terrain or obstacle elevation whichever is highest; plus
    - ii. 1 000 ft for elevation up to and including 6 000 ft; or
    - iii. 2 000 ft for elevation exceeding 6 000 ft rounded up to the next 100 ft.
  - 2.1.1 The lowest MOCA to be indicated is 2 000 ft.
  - 2.1.2 From a VOR station, the corridor width is defined as a borderline starting 5 nm either side of the VOR, diverging  $4^\circ$  from centerline until a width of 20 nm is reached at 70 nm out, thence paralleling the centerline until 140 nm out, thence again diverging  $4^\circ$  until a maximum width of 40 nm is reached at 280 nm out. Thereafter the width remains constant (See figure 1).

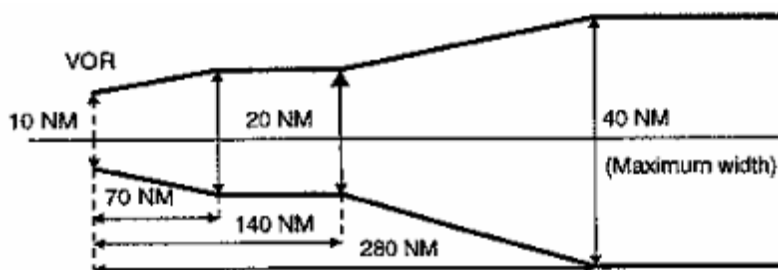

**FIGURE 1**

- 2.1.3 From an NDB, similarly, the corridor width is defined as a borderline starting 5 nm either side of the NDB diverging  $7^\circ$  until a width of 20 nm is reached 40 nm out, thence paralleling the centerline until 80 nm out, thence again diverging  $7^\circ$  until a maximum width of 60 nm is reached 245 nm out. Thereafter the width remains constant (See figure 2).

2.1.4 MOCA does not cover any overlapping of the corridor.

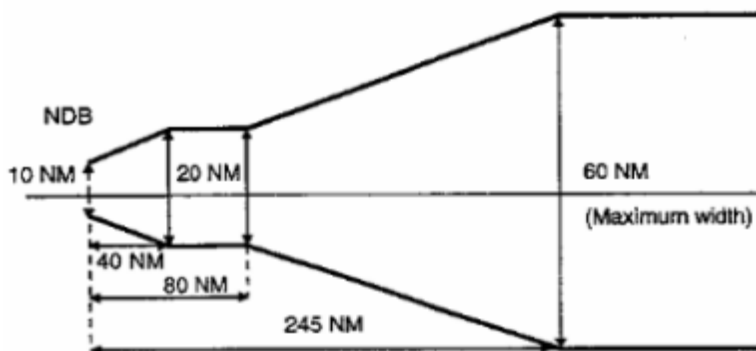

FIGURE 2

2.2 Minimum off-route altitude (MORA). MORA is calculated for an area bounded by every or every second LAT/LONG square on the Route Facility Chart (RFC)/Terminal Approach Chart (TAC) and is based on a terrain clearance as follows:

- i. Terrain with elevation up to 6 000 ft (2 000 m) – 1 000 ft above the highest terrain and obstructions;
- ii. Terrain with elevation above 6 000 ft (2 000 m) – 2 000 ft above the highest terrain and obstructions.

3 Jeppesen Formula (See figure 3)

3.1 MORA is a minimum flight altitude computed by Jeppesen from current ONC or WAC charts. Two types of MORAs are charted which are:

- i. Route MORAs e.g. 9800a; and
- ii. Grid MORAs e.g. 98.

3.2 Route MORA values are computed on the basis of an area extending 10 nm to either side of route centerline and including a 10 nm radius beyond the radio fix/reporting point or mileage break defining the route segment.

3.3 MORA values clear all terrain and man-made obstacles by 1 000 ft in areas where the highest terrain elevation or obstacles are up to 5 000 ft. A clearance of 2 000 ft is provided above all terrain or obstacles which are 5 001 ft and above.

3.4 A Grid MORA is an altitude computed by Jeppesen and the values are shown within each Grid formed by charted lines of latitude and longitude. Figures are shown in thousands and hundreds of feet (omitting the last two digits so as to avoid chart congestion). Values followed by ± are believed not to exceed the altitudes shown. The same clearance criteria as explained in paragraph 3.3 above apply.

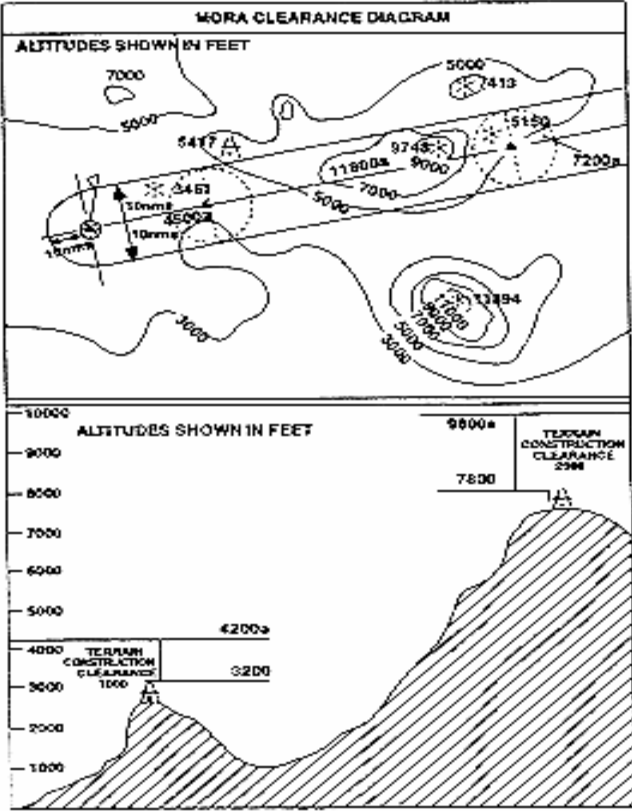

4. ATLAS Formula

- 4.1 Minimum safe En-route Altitude (MEA). Calculation of the MEA is based on the elevation of the highest point along the route segment concerned (extending from navigational aid to navigational aid) within a distance on either side of track as specified below:
- i. Segment length up to 100 nm - 10 nm (See Note 1 below).
  - ii. Segment length more than 100 nm – 10% of the segment length up to a maximum of 60 nm See Note 2 below).

NOTE 1. This distance may be reduced to 5 nm within TMAs where, due to the number and type of available navigational aids, a high degree of navigational accuracy is warranted

NOTE 2. In exceptional cases, where this calculation results in an operationally impracticable value, an additional special MEA may be calculated based on a distance of not less than 10 nm either side of track. Such special MEA will be shown together with an indication of the actual width of protected airspace.

- 4.2 The MEA is calculated by adding an increment to the elevation specified above as appropriate:

Elevation of highest point	Increment
Not above 5 000 ft	1 500 ft
Above 5 000 ft but not above 10 000 ft	2 000 ft
Above 10 000 ft	10% of elevation plus 1 000 ft

NOTE: For the last route segment ending over the initial approach fix, a reduction to 1 000 ft is permissible within TMAs where, due to the number and type of available navigation aids, a high degree of navigational accuracy is warranted.

The resulting value is adjusted to the nearest 100 ft.

- 4.3 Minimum safe Grid Altitude (MGA). Calculation of the MGA is based on the elevation of the highest point within the respective grid area.

The MGA is calculated by adding an increment to the elevation specified above as appropriate:

Elevation of highest point	Increment
Not above 5 000 ft	1 500 ft
Above 5 000 ft but not above 10 000 ft	2 000 ft
Above 10 000 ft	10% of elevation plus 1 000 ft

The resulting value is adjusted to the nearest 100 ft.



## **AC OPS 1.255**

### **Contingency Fuel Statistical Method**

See Appendix 1 to JCAR OPS 1.255 (a) (3) (i) (D)

1. As an example, the following values of statistical coverage of the deviation from the planned to the actual trip fuel provides appropriate statistical coverage:
  - a. 99% coverage plus 3% of the trip fuel, if the calculated flight time is less than two hours, or more than two hours and no suitable en-route alternate aerodrome is available;
  - b. 99% coverage if the calculated flight time is more than two hours and a suitable en-route alternate aerodrome is available;
  - c. 90% coverage if:
    - i. The calculated flight time is more than two hours; and
    - ii. A suitable en-route alternate aerodrome is available; and
    - iii. At the destination aerodrome two ( 2 ) separate runways are available and usable, one of which is equipped with an ILS/MLS, and the weather conditions are in compliance with JCAR OPS 1.295(c)(1)(ii); or the ILS/MLS is operational to Cat II/III operating minima and the weather conditions are at or above 500ft/2 500m.
2. The fuel consumption database used in conjunction with these values shall be based on fuel consumption monitoring for each route/airplane combination over a rolling two-year period.

## **AC OPS 1.260**

### **Carriage of persons with Reduced Mobility**

See JCAR OPS 1.260

1. A person with reduced mobility (PRM) is understood to mean a person whose mobility is reduced due to physical incapacity (sensory or locomotory), an intellectual deficiency, age, illness or any other cause of disability when using transport and when the situation needs special attention and the adaptation to a person's need of the service made available to all passengers.

2. In normal circumstances PRMs should not be seated adjacent to an emergency exit.
3. In circumstances in which the number of PRMs forms a significant proportion of the total number of passengers carried on board:
  - a. The number of PRMs should not exceed the number of able-bodied persons capable of assisting with an emergency evacuation; and
  - b. The guidance given in paragraph 2 above should be followed to the maximum extent possible.

### **AMC OPS 1.270**

#### **Cargo Carriage in the passenger cabin**

See JCAR OPS 1.270

1. In establishing procedures for the carriage of Cargo in the passenger cabin of an airplane, an operator should observe the following:
  - a. That dangerous goods are not permitted (See also JCAR OPS 1.1210(a));
  - b. That a mix of the passengers and live animals should not be permitted except for pets (weighing not more than 8 kg) and guide dogs;
  - c. That the weight of the Cargo does not exceed the structural loading limit(s) of the cabin floor or seat(s);
  - d. That the number/type of restraint devices and their attachment points should be capable of restraining the cargo in accordance with JCAR CS 25.789 or equivalent;
  - e. That the location of the cargo should be such that, in the event of an emergency evacuation, it will not hinder egress nor impair the cabin crew's view.

## **AC OPS 1.280**

### **Passenger Seating**

See JCAR OPS 1.280

1. An operator should establish procedures to ensure that:
  - a. Those passengers who are allocated seats which permit direct access to emergency exits appear to be reasonably fit, strong and able to assist the rapid evacuation of the airplane in an emergency after an appropriate briefing by the crew.
  - b. In all cases, passengers who, because of their condition, might hinder other passengers during an evacuation or who might impede the crew in carrying out their duties should not be allocated seats which permit direct access to emergency exits. If the operator is unable to establish procedures which can be implemented at the time of passenger 'check-in', he should establish an alternative procedure acceptable to CARC that the correct seat allocation will, in due course, be made.

## **AC OPS 1.280**

### **Passenger Seating**

See JCAR OPS 1.280 & AC OPS 1.280

1. The following categories of passengers are among those who should not be allocated to, or directed to seats which permit direct access to emergency exits:
  - a. Passengers suffering from obvious physical, or mental, handicap to the extent that they would have difficulty in moving quickly if asked to do so;
  - b. Passengers who are either substantially blind or substantially deaf to the extent that they might not readily assimilate printed or verbal instructions given;
  - c. Passengers who because of age or sickness are so frail that they have difficulty in moving quickly;

- d. Passengers who are so obese that they would have difficulty in moving quickly or reaching and passing through the adjacent emergency exit;
- e. Children (whether accompanied or not) and infants;
- f. Deportees or prisoners in custody; and,
- g. Passengers with animals.

Note. “Direct access” means a seat from which a passenger can proceed directly to the exit without entering an aisle or passing around an obstruction.

### **AC OPS 1.297(b) (2)**

#### **Planning Minima for Alternate Aerodromes**

See JCAR OPS 1.297(b) (2)

‘Non precision minima’ in JCAR OPS 1.297, Table 1, means the next highest minimum that is available in the prevailing wind and serviceability conditions; Localizer Only approaches, if published, are considered to be ‘non precision’ in this context. It is recommended that operators wishing to publish Tables of planning minima choose values that are likely to be appropriate on the majority of occasions (e.g. regardless of wind direction). Un-serviceability must, however, be fully taken into account.

# AMC OPS 1.297

## Application of aerodrome forecasts

See JCAR OPS 1.297

<u>APPLICATION OF AERODROME FORECASTS (TAF &amp; TREND) TO PRE-FLIGHT PLANNING (ICAO Annex 3 refers)</u>										
<p><b>1. APPLICATION OF INITIAL PART OF TAF</b> (For aerodrome planning minima see JAR-OPS 1.297)</p> <p>a) <b>Applicable time period:</b> From the start of the TAF validity period up to the time of applicability of the first subsequent 'FM...' or 'BECMG...' or, if no 'FM' or 'BECMG' is given, up to the end of the validity period of the TAF.</p> <p>b) <b>Application of forecast:</b> The prevailing weather conditions forecast in the initial part of the TAF should be fully applied with the exception of the <b>mean wind</b> and <b>gusts (and crosswind)</b> which should be applied in accordance with the policy in the column 'BECMG AT' and 'FM' in the table below. This may however be overruled temporarily by a 'TEMPO' or 'PROB**' if applicable acc. to the table below.</p>										
<u>2. APPLICATION OF FORECAST FOLLOWING CHANGE INDICATORS IN TAF AND TREND</u>										
TAF or TREND for AERODROME PLANNED AS:	FM (alone) and BECMG AT <b>Deterioration and Improvement</b>	BECMG (alone), BECMG FM, BECMG TL, BECMG FM, ... TL, in case of:		Deterioration		Improvement		Deterioration		PROB TEMPO <b>Deterioration and Improvement</b>
		Deterioration	Improvement	Transient/Showery Conditions in connection with short-lived weather phenomena, e.g. thunderstorms, showers	Persistent Conditions in connection with e.g. haze, mist, fog, dust/sandstorm, continuous precipitation	Improvement in any case				
<b>DESTINATION</b> at ETA ± 1 HR	Applicable from the <b>start of the change</b> .	Applicable from the <b>time of start</b> of the change.	Applicable from the <b>time of end</b> of the change.	Not applicable	Applicable	Mean wind: Should be within required limits;	Mean wind: Should be within required limits;	Mean wind: Should be within required limits;	Mean wind: Should be within required limits;	Deterioration may be disregarded; Improvement should be disregarded including mean wind and gusts.
<b>TAKE-OFF ALTERNATE</b> at ETA ± 1 HR	Mean wind: Should be within required limits; Gusts: May be disregarded.	Mean wind: Should be within required limits; Gusts: May be disregarded.	Mean wind: Should be within required limits; Gusts: May be disregarded.	Mean wind and gusts exceeding required limits may be <b>disregarded</b> .	Mean wind: Should be within required limits; Gusts: May be disregarded.	Mean wind: Should be within required limits; Gusts: May be disregarded.	Mean wind: Should be within required limits; Gusts: May be disregarded.	Mean wind: Should be within required limits; Gusts: May be disregarded.	Mean wind: Should be within required limits; Gusts: May be disregarded.	Should be disregarded.
<b>DEST. ALTERNATE</b> at ETA ± 1 HR	Mean wind: Should be within required limits; Gusts: May be disregarded.	Mean wind: Should be within required limits; Gusts: May be disregarded.	Mean wind: Should be within required limits; Gusts: May be disregarded.	Mean wind and gusts exceeding required limits may be <b>disregarded</b> .	Mean wind: Should be within required limits; Gusts: May be disregarded.	Mean wind: Should be within required limits; Gusts: May be disregarded.	Mean wind: Should be within required limits; Gusts: May be disregarded.	Mean wind: Should be within required limits; Gusts: May be disregarded.	Mean wind: Should be within required limits; Gusts: May be disregarded.	Should be disregarded.
<b>ENROUTE ALTERNATE</b> at ETA ± 1 HR (See JAR-OPS AMC 1.255)	Mean wind: Should be within required limits; Gusts: May be disregarded.	Mean wind: Should be within required limits; Gusts: May be disregarded.	Mean wind: Should be within required limits; Gusts: May be disregarded.	Mean wind and gusts exceeding required limits may be <b>disregarded</b> .	Mean wind: Should be within required limits; Gusts: May be disregarded.	Mean wind: Should be within required limits; Gusts: May be disregarded.	Mean wind: Should be within required limits; Gusts: May be disregarded.	Mean wind: Should be within required limits; Gusts: May be disregarded.	Mean wind: Should be within required limits; Gusts: May be disregarded.	Should be disregarded.
<b>ETOPS ENRT ALTN</b> at earliest/latest ETA ± 1 HR	Applicable from the <b>time of start of change</b> ; Mean wind: Should be within required limits; Gusts: exceeding crosswind limits should be fully applied.	Applicable from the <b>time of start of change</b> ; Mean wind: Should be within required limits; Gusts: exceeding crosswind limits should be fully applied.	Applicable from the <b>time of end of change</b> ; Mean wind: Should be within required limits; Gusts: exceeding crosswind limits should be fully applied.	Applicable from the <b>time of end of change</b> ; Mean wind: Should be within required limits; Gusts: exceeding crosswind limits should be fully applied.	Applicable if below applicable landing minima	Applicable if below applicable landing minima	Applicable if below applicable landing minima	Applicable if below applicable landing minima	Applicable if below applicable landing minima	Should be disregarded.

Note 1: 'Required limits' are those contained in the Operations Manual.

Note 2: If promulgated aerodrome forecasts do not comply with the requirements of ICAO Annex 3, operators should ensure that guidance in the application of these reports is provided.

\* The space following 'FM' should always include a time group e.g. 'FM1030'.

## **AMC OPS 1.300**

### **Submission of ATS Flight plan**

See JCAR OPS 1.300

1. Flights without ATS flight plan. When unable to submit or to close the ATS flight plan due to lack of ATS facilities or any other means of communications to ATS, an operator should establish procedures, instructions and a list of authorized persons to be responsible for alerting search and rescue services.
2. To ensure that each flight is located at all times, these instructions should:
  - a. Provide the authorized person with at least the information required to be included in a VFR Flight plan, and the location, date and estimated time for re-establishing communications;
  - b. If an airplane is overdue or missing, provide for notification to the appropriate ATS or Search and Rescue facility; and
  - c. Provide that the information will be retained at a designated place until the completion of the flight.

## **IEM OPS 1.305**

### **Refueling/Defueling with passengers embarking, on board or disembarking**

See JCAR OPS 1.305

When re/defueling with passengers on board, ground servicing activities and work inside the airplane, such as catering and cleaning, should be conducted in such a manner that they do not create a hazard and that the aisles and emergency doors are unobstructed.

## **IEM OPS 1.307**

### **Refueling/Defueling with wide-cut fuel**

See JCAR OPS 1.307

1. 'Wide cut fuel' (designated JET B, JP-4 or AVTAG) is an aviation turbine fuel that falls between gasoline and kerosene in the distillation range and consequently, compared to kerosene (JET A or JET A1), it has the properties of higher volatility (vapor pressure), lower flash point and lower freezing point.

2. Wherever possible, an operator should avoid the use of wide-cut fuel types. If a situation arises such that only wide-cut fuels are available for refueling/defueling, operators should be aware that mixtures of wide-cut fuels and kerosene turbine fuels can result in the air/fuel mixture in the tank being in the combustible range at ambient temperatures. The extra precautions set out below are advisable to avoid arcing in the tank due to electrostatic discharge. The risk of this type of arcing can be minimized by the use of a static dissipation additive in the fuel. When this additive is present in the proportions stated in the fuel specification, the normal fuelling precautions set out below are considered adequate.
3. Wide-cut fuel is considered to be “involved” when it is being supplied or when it is already present in aircraft fuel tanks.
4. When wide-cut fuel has been used, this should be recorded in the Technical Log. The next two uplifts of fuel should be treated as though they too involved the use of wide-cut fuel.
5. When refueling/defueling with turbine fuels not containing a static dissipater, and where wide -cut fuels are involved, a substantial reduction on fuelling flow rate is advisable. Reduced flow rate, as recommended by fuel suppliers and/or airplane manufacturers, has the following benefits:
  - a. It allows more time for any static charge build-up in the fuelling equipment to dissipate before the fuel enters the tank;
  - b. It reduces any charge which may build up due to splashing; and
  - c. Until the fuel inlet point is immersed, it reduces misting in the tank and consequently the extension of the flammable range of the fuel.
6. The flow rate reduction necessary is dependent upon the fuelling equipment in use and the type of filtration employed on the airplane fuelling distribution system. It is difficult, therefore, to quote precise flow rates. Reduction in flow rate is advisable whether pressure fuelling or over-wing fuelling is employed.
7. With over-wing fuelling, splashing should be avoided by making sure that the delivery nozzle extends as far as practicable into the tank. Caution should be exercised to avoid damaging bag tanks with the nozzle.

## **AC OPS 1.308**

### **Push Back and Towing**

See JCAR OPS 1.308

Tow bar less towing should be based on the applicable SAE ARP (Aerospace Recommended Practices), i.e.4852B/4853B/5283/5284/5285 (as amended).

## **AC OPS 1.310(a) (3)**

### **Controlled rest on flight deck**

See JCAR OPS 1.310(a) (3)

Even though crew members should stay alert at all times during flight, unexpected fatigue can occur as a result of sleep disturbance and circadian disruption. To cover for this unexpected fatigue, and to regain a high level of alertness, a controlled rest procedure on the Flight Deck can be used. Moreover, the use of controlled rest has been shown to increase significantly levels of alertness during the later phases of flight, particularly after the top of descent, and is considered a good use of CRM principles. Controlled rest should be used in conjunction with other on board fatigue management countermeasures such as physical exercise, bright cockpit illumination at appropriate times, balanced eating and drinking, and intellectual activity. The maximum rest time has been chosen to limit deep sleep with consequent long recovery time (sleep inertia).

1. It is the responsibility of all crew members to be properly rested before flight (See JCAR OPS 1.085).
2. This AC is concerned with controlled rest taken by the minimum certificated flight crew. It is not concerned with resting by members of an augmented crew.
3. Controlled rest means a period of time ‘off task’ some of which may include actual sleep.
4. Controlled rest may be used at the discretion of the commander to manage both sudden unexpected fatigue and fatigue which is expected to become more severe during higher workload periods later in the flight. It cannot be planned before flight.
5. Controlled rest should only take place during a low workload part of the flight.



6. Controlled rest periods should be agreed according to individual needs and the accepted principles of CRM; where the involvement of the cabin crew is required, consideration should be given to their workload.
7. Only one crew member at a time should take rest, at his station; the harness should be used and the seat positioned to minimize unintentional interference with the controls.
8. The commander should ensure that the other flight crew member(s) is (are) adequately briefed to carry out the duties of the resting crew member. One pilot must be fully able to exercise control of the airplane at all times. Any system intervention which would normally require a cross check according to multi crew principles should be avoided until the resting crew member resumes his duties.
9. Controlled rest may be taken according the following conditions:
  - a) The rest period should be no longer than 45 minutes (in order to limit any actual sleep to approximately 30 minutes).
  - b) After this 45-minute period, there should be a recovery period of 20 minutes during which sole control of the airplane should not be entrusted to the pilot who has completed his rest.
  - c) In the case of 2-crew operations, means should be established to ensure that the non-resting flight crew member remains alert. This may include:
    - Appropriate alarm systems
    - Onboard systems to monitor crew activity
    - Frequent Cabin Crew checks; In this case, the commander should inform the senior cabin crewmember of the intention of the flight crew member to take controlled rest, and of the time of the end of that rest; Frequent contact should be established between the flight deck and the cabin crew by means of the interphone, and cabin crew should check that the resting crew member is again alert at the end of the period. The frequency of the contacts should be specified in the Ops Manual.
10. A minimum 20 minute period should be allowed between rest periods to overcome the effects of sleep inertia and allow for adequate briefing.

11. If necessary, a flight crew member may take more than one rest period if time permits on longer sectors, subject to the restrictions above.
12. Controlled rest periods should terminate at least 30 minutes before top of descent.

### **IEM OPS 1.310(b)**

#### **Cabin crew seating positions**

See JCAR OPS 1.310(b)

1. When determining cabin crew seating positions, the operator should ensure that they are:
  - i. Close to a floor level exit;
  - ii. Provided with a good view of the area(s) of the passenger cabin for which the cabin crew member is responsible; and
  - iii. Evenly distributed throughout the cabin, in the above order of priority.
2. Paragraph 1 above should not be taken as implying that, in the event of there being more such cabin crew stations than required cabin crew; the number of cabin crew members should be increased.

### **AC OPS 1.311(b) (i)**

#### **Minimum number of cabin crew required to be on board an airplane during disembarkation when the number of passenger remaining on board is less than 20**

See JCAR OPS 1.311 (b) (i)

1. When developing the procedure (s) in relation to JCAR OPS 1.311 (b) (i) the following should be taken into account:
  - a. The possibility for gathering the remaining passenger in one part of each desk or of dick, depending upon their initial seat allocation
  - b. The possible occurrence of refueling/defueling
  - c. The associated number and distribution of cabin crew and the possible presence of flight crew on board, until the last passenger has disembarked
  - d. AC OPS 1.260 3 a

## **AC OPS 1.345**

### **Ice and other contaminants**

#### **Procedures**

##### **1. General**

- a. Any deposit of frost, ice, snow or slush on the external surfaces of an airplane may drastically affect its flying qualities because of reduced aerodynamic lift, increased drag, modified stability and control characteristics. Furthermore, freezing deposits may cause moving parts, such as elevators, ailerons, flap actuating mechanism etc., to jam and create a potentially hazardous condition.

Propeller/engine/APU/ systems performance may deteriorate due to the presence of frozen contaminants to blades, intakes and components. Also, engine operation may be seriously affected by the ingestion of snow or ice, thereby causing engine stall or compressor damage. In addition, ice/frost may form on certain external surfaces (e.g. wing upper and lower surfaces, etc.) due to the effects of cold fuel/structures, even in ambient temperatures well above 0° C.

- b. The procedures established by the operator for de-icing and/or anti-icing in accordance with JCAR OPS 1.345 are intended to ensure that the airplane is clear of contamination so that degradation of aerodynamic characteristics or mechanical interference will not occur and, following anti-icing, to maintain the airframe in that condition during the appropriate holdover time. The de-icing and/or anti-icing procedures should therefore include requirements, including type-specific, taking into account manufacturer's recommendations and cover:
  - (i) Contamination checks, including detection of clear ice and under-wing frost.  
Note. Limits on the thickness/area of contamination published in the AFM or other manufacturers' documentation should be followed;
  - (ii) De-icing and/or anti-icing procedures including procedures to be followed if de-icing and/or anti-icing procedures are interrupted or unsuccessful;
  - (iii) Post treatment checks;

- (iv) Pre take-off checks;
  - (v) Pre take-off contamination checks;
  - (vi) The recording of any incidents relating to de-icing and/or anti-icing; and
  - (vii) The responsibilities of all personnel involved in de-icing and/or anti-icing.
- c. Under certain meteorological conditions de-icing and/or anti-icing procedures may be ineffective in providing sufficient protection for continued operations. Examples of these conditions are freezing rain, ice pellets and hail, heavy snow, high wind velocity, fast dropping OAT or any time when freezing precipitation with high water content is present. No Holdover Time Guidelines exist for these conditions.
- d. Material for establishing operational procedures can be found, for example, in:
- ICAO annex 3, metrological service for international navigation
  - ICAO Doc 9640-AN/940 "Manual of aircraft ground de-icing/anti-icing operations";
  - ISO 11075 (\*) ISO Type I fluid;
  - ISO 11076 (\*) Aircraft de-icing/anti-icing methods with fluids;
  - ISO 11077 (\*) Self propelled de-icing/anti-icing vehicles-functional requirements;
  - ISO 11078 (\*) ISO Type II fluid;
  - AEA "Recommendations for de-icing/anti-icing of aircraft on the ground";
  - AEA "Training recommendations and background information for de-icing/anti-icing of aircraft on the ground";
  - EUROCAE ED-104/SAE AS 5116 Minimum operational performance specification for ground ice detection systems;
  - SAE ARP 4737 Aircraft de-icing/anti-icing methods;
  - SAE AMS 1424 Type I fluids;
  - SAE AMS 1428 Type II, III and IV fluids;
  - SAE ARP 1971 Aircraft De-icing Vehicle, Self-Propelled, Large and Small Capacity;
  - SAE ARD 50102 Forced air or forced air/fluid equipment for removal of frozen contaminants;
  - SAE ARP 5149 Training Program Guidelines for De-icing/Anti-icing of Aircraft on Ground.

(\*) The revision cycle of ISO documents is infrequent and therefore the documents quoted may not reflect the latest industry standards.

## 2. Terminology

Terms used in the context of this AC have the following meanings. Explanations of other definitions may be found elsewhere in the documents listed in 1 d. In particular, meteorological definitions may be found in ICAO doc. 9640.

- a. Anti-icing. The procedure that provides protection against the formation of frost or ice and accumulation of snow on treated surfaces of the airplane for a limited period of time (holdover time).
- b. Anti-icing fluid. Anti-icing fluid includes but is not limited to the following:
  - (i) Type I fluid if heated to min 60° C at the nozzle;
  - (ii) Mixture of water and Type I fluid if heated to min 60°C at the nozzle;
  - (iii) Type II fluid;
  - (iv) Mixture of water and Type II fluid;
  - (v) Type III fluid;
  - (vi) Mixture of water and Type III fluid;
  - (vii) Type IV fluid;
  - (viii) Mixture of water and Type IV fluid.

NOTE. On uncontaminated airplane surfaces Type II, III and IV anti-icing fluids are normally applied unheated.

- c. Clear ice. A coating of ice, generally clear and smooth, but with some air pockets. It forms on exposed objects, the temperature of which are at, below or slightly above the freezing temperature, by the freezing of super-cooled drizzle, droplets or raindrops.
- d. Conditions conducive to airplane icing on the ground. Freezing fog, freezing precipitation, frost, rain or high humidity (on cold soaked wings), mixed rain and snow and snow.
- e. Contamination. Contamination in this context is understood as all forms of frozen or semi-frozen moisture such as frost, snow, slush, or ice.

- f. Contamination check. Check of airplane for contamination to establish the need for de-icing.
- g. De-icing. The procedure by which frost, ice, snow or slush is removed from an airplane in order to provide uncontaminated surfaces.
- h. De-icing fluid. Such fluid includes, but is not limited to, the following:
  - (i) Heated water;
  - (ii) Type I fluid;
  - (iii) Mixture of water and Type I fluid;
  - (iv) Type II fluid;
  - (v) Mixture of water and Type II fluid;
  - (vi) Type III fluid;
  - (vii) Mixture of water and Type III fluid;
  - (viii) Type IV fluid;
  - (ix) Mixture of water and Type IV fluid.

NOTE. De-icing fluid is normally applied heated to ensure maximum efficiency.

- i. De-icing/anti-icing. This is the combination of de-icing and anti-icing performed in either one or two steps.
- j. Ground Ice Detection System (GIDS). System used during airplane ground operations to inform the ground crew and/or the flight crew about the presence of frost, ice, snow or slush on the airplane surfaces.
- k. Holdover time (HOT). The estimated period of time for which an anti-icing fluid is expected to prevent the formation of frost or ice and the accumulation of snow on the treated surfaces of an airplane on the ground in the prevailing ambient conditions.
- l. Lowest Operational Use Temperature (LOUT). The lowest temperature at which a fluid has been tested and certified as acceptable in accordance with the appropriate aerodynamic acceptance test whilst still maintaining a freezing point buffer of not less than:

10° C for a type I de-icing/anti-icing fluid,

7° C for type II, III or IV de-/anti-icing fluids

- m. Post treatment check. An external check of the airplane after de-icing and/or anti-icing treatment accomplished from suitably elevated observation points (e.g. from the de-icing equipment itself or other elevated equipment) to ensure that the airplane is free from any frost, ice, snow, or slush.
- n. Pre-take-off check. An assessment normally performed from within the flight deck, to validate the applied holdover time.
- o. Pre-take-off contamination check. A check of the treated surfaces for contamination, performed when the hold-over-time has been exceeded or if any doubt exists regarding the continued effectiveness of the applied anti-icing treatment. It is normally accomplished externally, just before the commencement of the take-off run.

### 3. Fluids

- a. Type I fluid. Due to its properties, Type I fluid forms a thin, liquid-wetting film on surfaces to which it is applied which, under certain weather conditions, gives a very limited holdover time. With this type of fluid, increasing the concentration of fluid in the fluid/water mix does not provide any extension in holdover time.
- b. Type II and type IV fluids contain thickeners which enable the fluid to form a thicker liquid-wetting film on surfaces to which it is applied. Generally, this fluid provides a longer holdover time than Type I fluids in similar conditions. With this type of fluid, the holdover time can be extended by increasing the ratio of fluid in the fluid/water mix.
- c. Type III fluid: a thickened fluid intended especially for use on airplanes with low rotation speeds.
- d. Fluids used for de-icing and/or anti-icing should be acceptable to the operator and the airplane manufacturer. These fluids normally conform to specifications such as SAE AMS 1424, 1428 or equivalent. Use of non-conforming fluids is not recommended due to their characteristics not being known.

Note. The anti-icing and aerodynamic properties of thickened fluids may be seriously degraded by, for example, inappropriate storage, treatment, application, application equipment and age.

#### 4. Communications

##### 4.1 Before airplane treatment.

When the airplane is to be treated with the flight crew on board, the flight and ground crews should confirm the fluid to be used, the extent of treatment required, and any airplane type specific procedure(s) to be used. Any other information needed to apply the HOT tables should be exchanged.

##### 4.2 Anti-icing code

- a. The operator's procedures should include an anti-icing code, which indicates the treatment the airplane has received. This code provides the flight crew with the minimum details necessary to estimate a holdover time (See para 5 below) and confirms that the airplane is free of contamination.
- b. The procedures for releasing the airplane after the treatment should therefore provide the Commander with the anti-icing code.
- c. Anti-icing Codes to be used (examples):
  - (i) "Type I" at (start time). To be used if anti-icing treatment has been performed with a Type I fluid;
  - (ii) "Type II/100" at (start time). To be used if anti-icing treatment has been performed with undiluted Type II fluid;
  - (iii) "Type II/75" at (start time). To be used if anti-icing treatment has been performed with a mixture of 75% Type II fluid and 25% water;
  - (iv) "Type IV/50" at (start time). To be used if anti-icing treatment has been performed with a mixture of 50% Type IV fluid and 50% water.



Note 1. When a two-step de-icing/anti-icing operation has been carried out, the Anti-Icing Code is determined by the second step fluid. Fluid brand names may be included, if desired.

#### 4.3 After Treatment

Before reconfiguring or moving the airplane, the flight crew should receive a confirmation from the ground crew that all de-icing and/or anti-icing operations are complete and that all personnel and equipment are clear of the airplane.

#### 5. Holdover protection

- a. Holdover protection is achieved by a layer of anti-icing fluid remaining on and protecting airplane surfaces for a period of time. With a one-step de-icing/anti-icing procedure, the holdover time (HOT) begins at the commencement of de-icing/anti-icing. With a two-step procedure, the holdover time begins at the commencement of the second (anti-icing) step. The holdover protection runs out:
  - (i) At the commencement of take-off roll (due to aerodynamic shedding of fluid) or
  - (ii) When frozen deposits start to form or accumulate on treated airplane surfaces, thereby indicating the loss of effectiveness of the fluid.
- b. The duration of holdover protection may vary subject to the influence of factors other than those specified in the holdover time (HOT) tables. Guidance should be provided by the operator to take account of such factors which may include:
  - (i) Atmospheric conditions, e.g. exact type and rate of precipitation, wind direction and velocity, relative humidity and solar radiation and
  - (ii) The airplane and its surroundings, such as airplane component inclination angle, contour and surface roughness, surface temperature, operation in close proximity to other airplanes (jet or propeller blast) and ground equipment and structures.

- c. Holdover times are not meant to imply that flight is safe in the prevailing conditions if the specified holdover time has not been exceeded. Certain meteorological conditions, such as freezing drizzle or freezing rain, may be beyond the certification envelope of the airplane.
  - d. The operator should publish in the Operations Manual the holdover times in the form of a table or diagram to account for the various types of ground icing conditions and the different types and concentrations of fluids used. However, the times of protection shown in these tables are to be used as guidelines only and are normally used in conjunction with pre-take-off check.
  - e. References to usable HOT tables may be found in the ‘AEA recommendations for de-/anti-icing aircraft on the ground’.
6. Procedures to be used. Operator’s procedures should ensure that:
- a. When airplane surfaces are contaminated by ice, frost, slush or snow, they are de-iced prior to take-off; according to the prevailing conditions. Removal of contaminants may be performed with mechanical tools, fluids (including hot water), infra-red heat or forced air, taking account of airplane type specific requirements.
  - b. Account is taken of the wing skin temperature versus OAT, as this may affect:
    - (i) The need to carry out airplane de-icing and/or anti-icing; an
    - (ii) The performance of the de-icing/anti-icing fluids.
  - b. When freezing precipitation occurs or there is a risk of freezing precipitation occurring, which would contaminate the surfaces at the time of take-off, airplane surfaces should be anti-iced. If both de-icing and anti-icing are required, the procedure may be performed in a one or two-step process depending upon weather conditions, available equipment, available fluids and the desired holdover time. One-step deicing/anti-icing means that de-icing and anti-icing are carried out at the same time using a mixture of deicing/ anti-icing fluid and water.

Two-step de-icing/anti-icing means that de-icing and anti-icing are carried out in two separate steps. The airplane is first de-iced using heated water only or a heated mixture of deicing/anti-icing fluid and water. After completion of the de-icing operation a layer of a mixture of deicing/anti-icing fluid and water, or of de-icing/anti-icing fluid only, is to be sprayed over the airplane surfaces. The second step will be applied, before the first step fluid freezes, typically within three minutes and, if necessary, area by area.

- d. When an airplane is anti-iced and a longer holdover time is needed / desired, the use of a less diluted Type II or Type IV fluid should be considered.
- e. All restrictions relative to Outside Air Temperature (OAT) and fluid application (including, but not necessarily limited to temperature and pressure), published by the fluid manufacturer and/or airplane manufacturer, are followed. Procedures, limitations and recommendations to prevent the formation of fluid residues are followed.
- f. During conditions conducive to airplane icing on the ground or after de-icing and/or anti-icing, an airplane is not dispatched for departure unless it has been given a contamination check or a post treatment check by a trained and qualified person. This check should cover all treated surfaces of the airplane and be performed from points offering sufficient accessibility to these parts. To ensure that there is no clear ice on suspect areas, it may be necessary to make a physical check (e.g. tactile).
- g. The required entry is made in the Technical Log. (See AMC OPS 1.915, par. 2, Section 3.vi)
- h. The Commander continually monitors the environmental situation after the performed treatment. Prior to take-off he performs a pre-take-off check, which is an assessment whether the applied HOT is still appropriate. This pre-take-off check includes, but is not limited to, factors such as precipitation, wind and OAT.

- i. If any doubt exists as to whether a deposit may adversely affect the airplane's performance and/or controllability characteristics, the Commander should require a pre-take-off contamination check to be performed in order to verify that the airplane's surfaces are free of contamination. Special methods and/or equipment may be necessary to perform this check, especially at night time or in extremely adverse weather conditions. If this check cannot be performed just prior take-off, re- treatment should be applied.
- j. When re-treatment is necessary, any residue of the previous treatment should be removed and a completely new de-icing/anti-icing treatment applied.
- k. When a Ground Ice Detection System (GIDS) is used to perform an airplane surfaces check prior to and/or after a treatment, the use of GIDS by suitably trained personnel should be a part of the procedure.

7. Special operational considerations

- a. When using thickened de-icing/anti-icing fluids, the operator should consider a two-step deicing/anti-icing procedure, the first step preferably with hot water and/or non thickened fluids.
- b. The use of de-icing/anti-icing fluids has to be in accordance with the airplane manufacturer's documentation. This is particular true for thickened fluids to assure sufficient flow-off during take-off.
- c. The operator should comply with any type-specific operational requirement(s) such as an airplane mass decrease and/or a take-off speed increase associated with a fluid application.
- d. The operator should take into account any flight handling procedures (stick force, rotation speed and rate, take-off speed, airplane attitude etc.) laid down by the airplane manufacturer when associated with a fluid application.
- e. The limitations or handling procedures resulting from c and/or d above should be part of the flight crew pre take-off briefing.

8. Special maintenance considerations

a. General

The operator should take proper account of the possible side-effects of fluid use. Such effects may include, but are not necessarily limited to, dried and/or re-hydrated residues, corrosion and the removal of lubricants.

b. Special considerations due to residues of dried fluids.

The operator should establish procedures to prevent or detect and remove residues of dried fluid. If necessary the operator should establish appropriate inspection intervals based on the recommendations of the airframe manufacturers and/or own experience:

- (i) Dried fluid residues. Dried fluid residue could occur when surfaces has been treated but the aircraft has not subsequently been flown and not been subject to precipitation. The fluid may then have dried on the surfaces;
- (ii) Re-hydrated fluid residues. Repetitive application of thickened de-icing/anti-icing fluids may lead to the subsequent formation/build up of a dried residue in aerodynamically quiet areas, such as cavities and gaps. This residue may re-hydrate if exposed to high humidity conditions, precipitation, washing, etc., and increase to many times its original size/volume. This residue will freeze if exposed to conditions at or below 0° C. This may cause moving parts such as elevators, ailerons, and flap actuating mechanisms to stiffen or jam in flight.

Re-hydrated residues may also form on exterior surfaces, which can reduce lift, increase drag and stall speed.

Re-hydrated residues may also collect inside control surface structures and cause clogging of drain holes or imbalances to flight controls.

Residues may also collect in hidden areas: around flight control hinges, pulleys, grommets, on cables and in gaps;

- (iii) Operators are strongly recommended to request information about the fluid dry-out and rehydration characteristics from the fluid manufacturers and to select products with optimized characteristics;
- (iv) Additional information should be obtained from fluid manufacturers for handling, storage, application and testing of their products.

## 9. Training

- a. An operator should establish appropriate initial and recurrent de-icing and/or anti-icing training programs (including communication training) for flight crew and those of his ground crew who are involved in de-icing and/or anti-icing.
- b. These de-icing and/or anti-icing training programs should include additional training if any of the following will be introduced:
  - (i) A new method, procedure and/or technique;
  - (ii) A new type of fluid and/or equipment; and
  - (iii) A new type(s) of airplane.
- c. An operator should establish appropriate initial and recurrent training for the cabin crew, which includes:
  - (i) Awareness of the effect of surface contamination, and
  - (ii) The need to inform the flight crew of any observed surface contamination

## 10. Subcontracting (See AMC OPS 1.035 sections 4 and 5)

The operator should ensure that the subcontractor complies with the operator's quality and training/qualification requirements together with the special requirements in respect of:

- a. De-icing and/or anti-icing methods and procedures
- b. Fluids to be used, including precautions for storage and preparation for use;

- c. Specific airplane requirements (e.g. no-spray areas, propeller/engine de-icing, APU operation etc.);
- d. Checking and communications procedures.

## **AC OPS 1.346**

### **Flight in expected or actual icing conditions**

See JCAR OPS 1.346

1. The procedures to be established by an operator should take account of the design, the equipment or the configuration of the airplane and also of the training which is needed. For these reasons, different airplane types operated by the same company may require the development of different procedures. In every case, the relevant limitations are those which are defined in the Airplane Flight Manual (AFM) and other documents produced by the manufacturer.
2. For the required entries in the Operations Manual, the procedural principles which apply to flight in icing conditions are referred to under Appendix 1 to JCAR OPS 1.1045, A 8.3.8 and should be cross-referenced, where necessary, to supplementary, type-specific data under B 4.1.1.
3. Technical content of the Procedures. The operator should ensure that the procedures take account of the following:
  - a. JCAR OPS 1.675;
  - b. The equipment and instruments which must be serviceable for flight in icing conditions;
  - c. The limitations on flight in icing conditions for each phase of flight. These limitations may be imposed by the airplane's de-icing or anti-icing equipment or the necessary performance corrections which have to be made;
  - d. The criteria the Flight Crew should use to assess the effect of icing on the performance and/or controllability of the airplane;

- e. The means by which the Flight Crew detects, by visual cues or the use of the airplane's ice detection system, that the flight is entering icing conditions; and
  - f. The action to be taken by the Flight Crew in a deteriorating situation (which may develop rapidly) resulting in an adverse affect on the performance and/or controllability of the airplane, due to either:
    - i. The failure of the airplane's anti-icing or de-icing equipment to control a build-up of ice, and/or
    - ii. Ice build-up on unprotected areas.
4. Training for dispatch and flight in expected or actual icing conditions. The content of the Operations Manual, Part D, should reflect the training, both conversion and recurrent, which Flight Crew, Cabin Crew and all other relevant operational personnel will require in order to comply with the procedures for dispatch and flight in icing conditions.
- 4.1 For the Flight Crew, the training should include:
- a. Instruction in how to recognize, from weather reports or forecasts which are available before flight commences or during flight, the risks of encountering icing conditions along the planned route and on how to modify, as necessary, the departure and in-flight routes or profiles;
  - b. Instruction in the operational and performance limitations or margins;
  - c. The use of in-flight ice detection, anti-icing and de-icing systems in both normal and abnormal operation; and
  - d. Instruction in the differing intensities and forms of ice accretion and the consequent action which should be taken.
- 4.2 For the Cabin Crew, the training should include;
- a. Awareness of the effects of surface contamination; and
  - b. The need to inform the Flight Crew of any observed surface contamination.



## **AC OPS 1.390(a) (1)**

### **Assessment of Cosmic Radiation**

See JCAR OPS 1.390(a) (1)

1. In order to show compliance with JCAR OPS 1.390(a), an operator should assess the likely exposure for crew members so that he can determine whether or not action to comply with JCAR OPS 1.390(a)(2), (3), (4) and (5) will be necessary.
  - a. Assessment of exposure level can be made by the method described below, or other method acceptable to CARC:

Table 1 - Hours exposure for effective dose of 1 millisievert (mSv)

Altitude (feet)	Kilometer equivalent	Hours at latitude 60o N	Hours at equator
27 000	8.23	630	1330
30 000	9.14	440	980
33 000	10.06	320	750
36 000	10.97	250	600
39 000	11.89	200	490
42 000	12.80	160	420
45 000	13.72	140	380
48 000	14.63	120	350

Note. This table, published for illustration purposes, is based on the CARI-3 computer program; and may be superseded by updated versions, as approved by CARC.

The uncertainty on these estimates is about  $\pm 20\%$ . A conservative conversion factor of 0.8 has been used to convert ambient dose equivalent to effective dose.

- b. Doses from cosmic radiation vary greatly with altitude and also with latitude and with the phase of the solar cycle. Table 1 gives an estimate of the number of flying hours at various altitudes in which a dose of 1 mSv would be accumulated for flights at 60° N and at the equator. Cosmic radiation dose rates change reasonably slowly with time at altitudes used by conventional jet aircraft (i.e. up to about 15 km / 49 000 ft).

- c. Table 1 can be used to identify circumstances in which it is unlikely that an annual dosage level of 1 mSv would be exceeded. If flights are limited to heights of less than 8 km (27 000 ft), it is unlikely that annual doses will exceed 1 mSv. No further controls are necessary for crew members whose annual dose can be shown to be less than 1 mSv.

### **AC OPS 1.390(a) (2)**

#### **Working Schedules and Record Keeping**

See JCAR OPS 1.390(a) (2)

Where in-flight exposure of crew members to cosmic radiation is likely to exceed 1 mSv per year the operator should arrange working schedules, where practicable, to keep exposure below 6 mSv per year. For the purpose of this regulation crew member who is likely to be exposed to more than 6 mSv per year are considered highly exposed and individual records of exposure to cosmic radiation should be kept for each crew member concerned.

### **AC OPS 1.390(a) (3)**

#### **Explanatory Information**

See JCAR OPS 1.390(a) (3)

Operators should explain the risks of occupational exposure to cosmic radiation to their crew members. Female crew members should know of the need to control doses during pregnancy, and the operator consequently notified so that the necessary dose control measures can be introduced.

### **AC OPS 1.398**

#### **Use of Airborne Collision Avoidance System (ACAS)**

See JCAR OPS 1.398

1. The ACAS operational procedures and training programs established by the operator should take into account TGL 11 "Guidance for Operators on Training Programs for the use of ACAS". This TGL incorporates advice contained in:
  - a. ICAO Annex 10 Volume 4;
  - b. ICAO Doc 8168 PANS OPS Volume 1;

- c. ICAO Doc 4444 PANS RAC Part X paragraph 3.1.2; and
- d. ICAO guidance material “ACAS Performance - Based Training Objectives” (published under Attachment E to State letter AN 7/1.3.7.2-97/77.)

### **IEM OPS 1.400**

#### **Approach and Landing Conditions**

See JCAR OPS 1.400

The in-flight determination of the landing distance should be based on the latest available report, preferably not more than 30 minutes before the expected landing time.

## **Appendix 1 to AMC OPS 1.245(a) (2)**

### **Power supply to essential services**

1. Any one of the three electrical power sources referred to in sub-paragraph 2.b of AMC OPS 1.245(a) (2) should be capable of providing power for essential services which should normally include:
  - a. Sufficient instruments for the flight crew providing, as a minimum, attitude, heading, airspeed and altitude information;
  - b. Appropriate pitot heating;
  - c. Adequate navigation capability;
  - d. Adequate radio communication and intercommunication capability;
  - e. Adequate flight deck and instrument lighting and emergency lighting;
  - f. Adequate flight controls;
  - g. Adequate engine controls and restart capability with critical type fuel (from the stand-point of flame-out and restart capability) and with the airplane initially at the maximum relight altitude;
  - h. Adequate engine instrumentation;
  - i. Adequate fuel supply system capability including such fuel boost and fuel transfer functions that may be necessary for extended duration single or dual engine operation;
  - j. Such warnings, cautions and indications as are required for continued safe flight and landing;
  - k. Fire protection (engines and APU);
  - l. Adequate ice protection including windshield de-icing; and
  - m. Adequate control of the flight deck and cabin environment including heating and pressurization.
2. The equipment (including avionics) necessary for extended diversion times should have the ability to operate acceptably following failures in the cooling system or electrical power systems.

## **AC/AMC/IEM E**

### **All Weather Operations**

#### **AC OPS 1.430**

#### **Continuous Descent Final Approach (CDFA)**

See Appendix 1 to JCAR OPS 1.430

1. Introduction
  - 1.1 Controlled-Flight-Into-Terrain (CFIT) is a major causal category of accident and hull loss in commercial aviation. Most CFIT accidents occur in the final approach segment of non-precision approaches; the use of stabilized-approach criteria on a continuous descent with a constant, predetermined vertical path is Seen as a major improvement in safety during the conduct of such approaches. Operators should ensure that the following techniques are adopted as widely as possible, for all approaches.
  - 1.2 The elimination of level flight segments at Minimum Descent Altitude (MDA) close to the ground during approaches, and the avoidance of major changes in attitude and power / thrust close to the runway which can destabilize approaches, are Seen as ways to reduce operational risks significantly.
  - 1.3 For completeness this AC also includes criteria which should be considered to ensure the stability of an approach (in terms of the airplane's energy and approach-path control).
  - 1.4 The term Continuous Descent Final Approach (CDFA) has been selected to cover a technique for any type of non-precision approach.
  - 1.5 Non-precision approaches operated other than using a constant pre-determined vertical path or when the facility requirements and associated conditions do not meet the conditions specified in Para 2.4 below RVR penalties apply. However, this should not preclude an operator from applying CDFA technique to such approaches. Those operations should be classified as special letdown procedures, since it has been shown that such operations, flown without additional training, may lead to inappropriately steep descent to the MDA (H), with continued descent below the MDA (H) in an attempt to gain (adequate) visual reference.

1.6 The advantages of CDFA are:

- a. The technique enhances safe approach operations by the utilization of standard operating practices;
- b. The profile reduces the probability of infringement of obstacle-clearance along the final approach segment and allows the use of MDA as DA;
- c. The technique is similar to that used when flying an ILS approach, including when executing the missed approach and the associated go-around maneuver;
- d. The airplane attitude may enable better acquisition of visual cues;
- e. The technique may reduce pilot workload;
- f. The Approach profile is fuel efficient;
- g. The Approach profile affords reduced noise levels;
- h. The technique affords procedural integration with APV approach operations;
- i. When used and the approach is flown in a stabilized manner is the safest approach technique for all approach operations.

2 CDFA (Continuous Descent Final Approach)

2.1 Continuous Descent Final Approach. A specific technique for flying the final approach segment of a non-precision instrument approach procedure as a continuous descent, without level-off, from an altitude/height at or above the final approach fix altitude/height to a point approximately 15m (50 ft) above the landing runway threshold or the point where the flare maneuver should begin for the type of aircraft flown.

2.2 An approach is only suitable for application of CDFA technique when it is flown along a predetermined vertical slope (See sub- paragraph (a) below) which follows a designated or nominal vertical profile (See sub-paragraphs (b) and (c) below):

- a. Predetermined Approach Slope: Either the designated or nominal vertical profile of an approach.
  - i. Designated Vertical Profile: A continuous vertical approach profile which forms part of the approach procedure design. APV is considered to be an approach with a designated vertical profile.
  - ii. Nominal Vertical Profile: A vertical profile not forming part of the approach procedure design, but which can be flown as a continuous descent.

Note. The nominal vertical profile information may be published or displayed (on the approach chart) to the pilot by depicting the nominal slope or range / distance vs height.

Approaches with a nominal vertical profile are considered to be:

- a. NDB, NDB/DME;
- b. VOR, VOR/DME;
- c. LLZ, LLZ/DME;
- d. VDF, SRA or
- e. RNAV/LNAV.

2.3 Stabilized Approach (SAp). An approach which is flown in a controlled and appropriate manner in terms of configuration, energy and control of the flight path from a pre-determined point or altitude/height down to a point 50 feet above the threshold or the point where the flare maneuver is initiated if higher.

- a. The control of the descent path is not the only consideration when using the CDFFA technique. Control of the airplane's configuration and energy is also vital to the safe conduct of an approach.
- b. The control of the flight path, described above as one of the requirements for conducting a SAp, should not be confused with the path requirements for using the CDFFA technique. The pre-determined path requirements for conducting SAp are established by the operator and published in the Operations Manual (OM) Part B; guidance for conducting SAp operations is given in paragraph 5 below.

- c. The predetermined approach slope requirements for applying the CDFA technique are established by:
  - i. The instrument-procedure design when the approach has a designated vertical profile;
  - ii. The published 'nominal' slope information when the approach has a nominal vertical profile;
  - iii. The designated final-approach segment minimum of 3nm, and maximum, when using timing techniques, of 8nm.
- d. A Stabilized Approach will never have any level segment of flight at DA (H) (or MDA (H) as applicable). This enhances safety by mandating a prompt go-around maneuver at DA (H) (or MDA (H))
- e. An approach using the CDFA technique will always be flown as an SAp, since this is a requirement for applying CDFA; however, an SAp does not have to be flown using the CDFA technique, for example a visual approach.

#### 2.4 Approach with a designated vertical profile using the CDFA technique:

- a. The optimum angle for the approach slope is 3 degrees, and the gradient should preferably not exceed 6.5 percent which equates to a slope of 3.77 degrees, (400 ft/NM) for procedures intended for conventional airplane types/classes and/or operations. In any case, conventional approach slopes should be limited to 4.5 degrees for Category A and B airplanes and 3.77 degrees for Category C and D airplanes, which are the upper limits for applying the CDFA technique. A 4.5 degree approach slope is the upper limit for certification of conventional airplanes.
- b. The approach is to be flown utilizing operational flight techniques and onboard navigation system(s) and navigation aids to ensure it can be flown on the desired vertical path and track in a stabilized manner, without significant vertical path changes during the final-segment descent to the runway. APV is included.
- c. The approach is flown to a DA (H).
- d. No MAPt is published for these procedures.



2.5 Approach with a nominal vertical profile using the CDFA technique:

- a. The optimum angle for the approach slope is 3 degrees, and the gradient should preferably not exceed 6.5 percent which equates to a slope of 3.77 degrees, (400 ft/NM) for procedures intended for conventional airplane types / class and / or operations. In any case, conventional approaches should be limited to 4.5 degrees for Category A and B airplanes and 3.77 degrees for Category C and D airplanes, which are the upper limits for applying CDFA technique. A 4.5 degree approach slope is the upper limit for certification of conventional airplanes.
- b. The approach should meet at least the following facility requirements and associated conditions. NDB, NDB/DME, VOR, VOR/DME, LLZ, LLZ/DME, VDF, SRA, RNAV (LNAV) with a procedure which fulfils the following criteria:
  - i. The final approach track off-set  $\leq 5$  degrees except for Category A and B airplanes, where the approach-track off-set is  $\leq 15$  degrees; and
  - ii. A FAF, or another appropriate fix where descent is initiated is available; and
  - iii. The distance from the FAF to the THR is less than or equal to 8 NM in the case of timing; or
  - iv. The distance to the threshold (THR) is available by FMS/RNAV or DME; or
  - v. The minimum final-segment of the designated constant angle approach path should not be less than 3 NM from the THR unless approved by CARC.
- c. CDFA may also be applied utilizing the following:
  - i. RNAV/LNAV with altitude/height cross checks against positions or distances from the THR; or
  - ii. Height crosscheck compared with DME distance values.

- d. The approach is flown to a DA (H).
- e. The approach is flown as an SAp.

Note. Generally, a MAPt is published for these procedures.

### 3. Operational Procedures

- 3.1 A MAPt should be specified to apply CDFA with a nominal vertical profile as for any non-precision approach.
- 3.2 The flight techniques associated with CDFA employ the use of a predetermined approach slope. The approach, in addition, is flown in a stabilized manner, in terms of configuration, energy and control of the flight path. The approach should be flown to a DA (H) at which the decision to land or go-around is made immediately. This approach technique should be used when conducting:
  - a. All non-precision approaches (NPA) meeting the specified CDFA criteria in Para 2.4; and
  - b. All approaches categorized as APV.
- 3.3 The flight techniques and operational procedures prescribed above should always be applied; in particular with regard to control of the descent path and the stability of the airplane on the approach prior to reaching MDA (H). Level flight at MDA (H) should be avoided as far as practicable. In addition appropriate procedures and training should be established and implemented to facilitate the applicable elements of paragraphs 4, 5 and 8. Particular emphasis should be placed on subparagraphs 4.8, 5.1 to 5.7 and 8.4.
- 3.4 In cases where the CDFA technique is not used with high MDA (H), it may be appropriate to make an early descent to MDA (H) with appropriate safeguards to include the above training requirements, as applicable, and the application of a significantly higher RVR/Visibility.

- 3.5 For Circling Approaches (Visual Maneuvering), all the applicable criteria with respect to the stability of the final descent path to the runway should apply. In particular, the control of the desired final nominal descent path to the threshold should be conducted to facilitate the techniques described in paragraphs 4 and 5 of this AC.
- a. Stabilization during the final straight-in segment for a circling approach should ideally be accomplished by 1000 ft above aerodrome elevation for turbo-jet airplanes.
  - b. For a circling approach where the landing runway threshold and appropriate visual landing aids may be visually acquired from a point on the designated or published procedure (prescribed tracks), stabilization should be achieved not later than 500 ft above aerodrome elevation. It is however recommended that the airplane be stabilized when passing 1000 ft above aerodrome elevation.
  - c. When a low-level final turning maneuver is required in order to align the airplane visually with the landing runway, a height of 300 ft above the runway threshold elevation, or aerodrome elevation as appropriate, should be considered as the lowest height for approach stabilization with wings level.
  - d. Dependent upon airplane type/class the operator may specify an appropriately higher minimum stabilization height for circling approach operations.
  - e. The operator should specify in the OM the procedures and instructions for conducting circling approach to include at least:
    - i. The minimum required visual reference; and
    - ii. The corresponding actions for each segment of the circling maneuver; and
    - iii. The relevant go-around actions if the required visual reference is lost.
    - iv. The visual reference requirements for any operations with a prescribed track circling maneuver to include the MDA (H) and any published MAPt.

- 3.6 Visual Approach. All the applicable criteria with respect to the stability of the final descent path to the runway should apply to the operation of visual approaches. In particular, the control of the desired final nominal descent path to the threshold should be conducted to facilitate the appropriate techniques and procedures described in paragraphs 6 and 7 of this proposed AC.
- a. Stabilization during the final straight-in segment for a visual approach should ideally be accomplished by 500 ft above runway threshold elevation for turbo-jet airplanes.
  - b. When a low level final turning maneuver is required in order to align the airplane with the landing runway, a minimum height of 300 ft above the runway threshold elevation (or aerodrome elevation as appropriate) should be considered as the lowest height for visual approach stabilization with wings level.
  - c. Dependent upon airplane type/class, the operator may specify an appropriately higher minimum stabilization height for visual approach operations.
  - d. The operator should specify in the OM the procedures and instructions for conducting visual approaches to include at least:
    - i. The minimum required visual reference; and
    - ii. The corresponding actions if the required visual reference is lost during a visual approach maneuver; and
    - iii. The appropriate go around actions.
- 3.7 The control of the descent path using the CDFFA technique ensures that the descent path to the runway threshold is flown using either:
- a. A variable descent rate or flight path angle to maintain the desired path, which may be verified by appropriate crosschecks; or
  - b. A pre-computed constant rate of descent from the FAF, or other appropriate fix which is able to define a descent point and/or from the final approach segment step-down fix; or

- c. Vertical guidance, including APV.
  - d. The above techniques also support a common method for the implementation of flight-director-guided or auto-coupled RNAV (VNAV) or GLS approaches.
- 3.8 Missed Approach - The maneuver associated with the vertical profile of the missed approach should be initiated not later than reaching the MAPt or the DA (H) specified for the approach, whichever occurs first. The lateral part of the missed approach procedure must be flown via the MAPt unless otherwise stated on the approach chart.
- 3.9 In case the CDFA technique is not used the approach should be flown to an altitude/height at or above the MDA(H) where a level flight segment at or above MDA(H) may be flown to the MAPt.
- 3.10 In case the CDFA technique is not used when flying an approach, an operator should implement procedures to ensure that early descent to the MDA (H) will not result in a subsequent flight below MDA (H) without adequate visual reference. These procedures could include:
- a. Awareness of radio altimeter information with reference to the approach profile;
  - b. Enhanced Ground Proximity Warning System and / or Terrain Awareness information;
  - c. Limitation of rate of descent;
  - d. Limitation of the number of repeated approaches;
  - e. Safeguards against too early descents with prolonged flight at MDA (H);
  - f. Specification of visual requirements for the descent from the MDA (H).

4 Flight techniques

- 4.1 The CDFA technique can be used on almost any published non-precision approach when the control of the descent path is aided by either:
- a. A recommended descent rate, based on estimated ground speed, which may be provided on the approach chart; or
  - b. The descent path as depicted on the chart.
- 4.2 In order to facilitate the requirement of paragraph 4.1.2 above, the operator should either provide charts which depict the appropriate cross check altitudes/heights with the corresponding appropriate range information, or such information should be calculated and provided to the flight-crew in an appropriate and useable format.
- 4.3 For approaches flown coupled to a designated descent path using computed electronic glide slope guidance (normally a 3 degree path), the descent path should be appropriately coded in the flight management system data base and the specified navigational accuracy (RNP) should be determined and maintained throughout the operation of the approach.
- 4.4 With an actual or estimated ground speed, a nominal vertical profile and required descent rate, the approach should be flown by crossing the FAF configured and on-speed. The tabulated or required descent rate is established and flown to not less than the DA(H), observing any step-down crossing altitudes if applicable.
- 4.5 To assure the appropriate descent path is flown, the pilot not-flying should announce crossing altitudes as published fixes and other designated points are crossed, giving the appropriate altitude or height for the appropriate range as depicted on the chart. The pilot flying should promptly adjust the rate of descent as appropriate.
- 4.6 With the required visual reference requirements established, the airplane should be in position to continue descent through the DA (H) or MDA (H) with little or no adjustment to attitude or thrust/power.

- 4.7 When applying CDFAs on an approach with a nominal vertical profile to a DA (H), it may be necessary to apply an add-on to the published minima (vertical profile only) to ensure sufficient obstacle clearance. The add on, if applicable, should be published in the OM (Aerodrome Operating Minima). However, the resulting procedure minimum will still be referred to as the DA (H) for the approach.
- 4.8 Operators should establish a procedure to ensure that an appropriate callout (automatic or oral) is made when the airplane is approaching DA (H). If the required visual references are not established at DA (H), the missed-approach procedure is to be executed promptly. Visual contact with the ground alone is not sufficient for continuation of the approach. With certain combinations of DA (H), RVR and approach slope, the required visual references may not be achieved at the DA (H) in spite of the RVR being at or above the minimum required for the conduct of the approach. The safety benefits of CDFAs are negated if prompt go-around action is not initiated.
- 4.9 The following bracketing conditions in relation to angle of bank, rate of descent and thrust /power management are considered to be suitable for most airplane types/class to ensure the predetermined vertical path approach is conducted in a stabilized manner:
- a. Bank angle: As prescribed in the AOM, should generally be less than 30 degrees;
  - b. Rate of descent (ROD): The target ROD should not exceed 1000 fpm. The ROD should deviate by no more than + 300 feet per minute (fpm) from the target ROD. Prolonged rates of descent which differ from the target ROD by more than 300 fpm indicate that the vertical path is not being maintained in a stabilized manner. The ROD should not exceed 1200 fpm except under exceptional circumstances, which have been anticipated and briefed prior to commencing the approach; for example, a strong tailwind.

Note. Zero rate of descent may be used when the descent path needs to be regained from below the profile. The target ROD may need to be initiated prior to reaching the required descent point (typically 0.3NM before the descent point, dependent upon ground speed, which may vary for each type/class of airplane). See (c) below

- c. Thrust/power management: The limits of thrust/power and the appropriate range should be specified in the OM, Part B or equivalent documents
- 4.10 Transient corrections/ Overshoots: The above-specified range of corrections should normally be used to make occasional momentary adjustments in order to maintain the desired path and energy of the airplane. Frequent or sustained overshoots should require the approach to be abandoned and a go around initiated. A correction philosophy should be applied similar to that described in paragraph 5 below.
- 4.11 The relevant elements of paragraph 4 above should, in addition, be applied to approaches not flown using the CDFA technique; the procedures thus developed, thereby ensure a controlled flight path to MDA (H). Dependent upon the number of step down fixes and the airplane type/class, the airplane should be appropriately configured to ensure safe control of the flight path prior to the final descent to MDA (H).
- 5 Stabilization of energy/speed and configuration of the airplane on the approach
- 5.1 The control of the descent path is not the only consideration. Control of the airplane's configuration and energy is also vital to the safe conduct of an approach.
- 5.2 The approach should be considered to be fully stabilized when the airplane is:
- a. Tracking on the required approach path and profile; and
  - b. In the required configuration and attitude; and
  - c. Flying with the required rate of descent and speed; and
  - d. Flying with the appropriate thrust/power and trim.
- 5.3 The following flight path control criteria should be met and maintained when the airplane passes the gates described in paragraphs 5.6 and 5.7 below.



- 5.4 The airplane is considered established on the required approach path at the appropriate energy for stable flight using the CDFA technique when:
- a. It is tracking on the required approach path with the correct track set, approach aids tuned and identified as appropriate to the approach type flown and on the required vertical profile; and
  - b. It is at the appropriate attitude and speed for the required target ROD with the appropriate thrust/power and trim.
- 5.5 It is recommended to compensate for strong wind/gusts on approach by speed increments given in the Airplane Operations Manual (AOM). To detect wind shear and magnitude of winds aloft, all available airplane equipment such as FMS, INS, etc. should be used.
- 5.6. It is recommended that stabilization during any straight-in approach without visual reference to the ground should be achieved at the latest when passing 1,000 ft above runway threshold elevation. For approaches with a designated vertical profile applying CDFA, a later stabilization in speed may be acceptable if higher than normal approach speeds are required by ATC procedures or allowed by the OM. Stabilization should, however, be achieved not later than 500 ft above runway threshold elevation.
- 5.7 For approaches where the pilot has visual reference with the ground, stabilization should be achieved not later than 500 ft above aerodrome elevation. However, it is recommended that the airplane should be stabilized when passing 1,000 ft above runway threshold elevation.
- 5.8 The relevant elements of paragraph 5 above should in addition be applied to approaches not flown using the CDFA technique; the procedures thus developed ensure that a controlled and stable path to MDA (H) is achieved. Dependent upon the number of step down fixes and the airplane type/class, the airplane should be appropriately configured to ensure safe and stable flight prior to the final descent to MDA (H).

- 6 Visual Reference and path-control below MDA (H) when not using the CDFFA technique
  - 6.1 In addition to the requirements stated in Appendix 1 to JCAR OPS 1.430, the pilot should have attained a combination of visual cues to safely control the airplane in roll and pitch to maintain the final approach path to landing. This must be included in the standard operating procedures and reflected in the OM.
- 7 Operational Procedures and Instructions for using the CDFFA technique or not.
  - 7.1 The operator should establish procedures and instructions for flying approaches using the CDFFA technique and not. These procedures should be included in the OM and should include the duties of the flight crew during the conduct of such operations.
    - a. The operator should publish in the OM the requirements stated in paragraphs 4 and 5 above, as appropriate to the airplane type or class to be operated.
    - b. The checklists should be completed as early as practicable and preferably before commencing final descent towards the DA (H).
  - 7.2 The operator's manuals should at least specify the maximum ROD for each airplane type/class operated and the required visual reference to continue the approach below:
    - a. The DA (H) when applying CDFFA;
    - b. MDA (H) when not applying CDFFA.
  - 7.3 The operator should establish procedures which prohibit level flight at MDA (H) without the flight crew having obtained the required visual references.

Note. It is not the intention of this paragraph to prohibit level flight at MDA (H) when conducting a circling approach, which does not come within the definition of the CDFFA technique.

- 7.4 The operator should provide the flight crew with:
- a. Unambiguous details of the technique used (CDFA or not).
  - b. The corresponding relevant minima should include:
    - i. Type of decision, whether DA (H) or MDA (H);
    - ii. MAPt as applicable;
    - iii. Appropriate RVR/Visibility for the approach classification and airplane category.
- 7.5 Specific types/class of airplane, in particular certain Performance Class B and Class C airplanes, may be unable to comply fully with the requirements of this AC relating to the operation of CDFA. This problem arises because some airplanes must not be configured fully into the landing configuration until required visual references are obtained for landing, because of inadequate missed approach performance engine out. For such airplanes, the operator should either:
- a. Obtain approval from CARC for an appropriate modification to the stipulated procedures and flight techniques prescribed herein; or
  - b. Increase the required minimum RVR to ensure the airplane will be operated safely during the configuration change on the final approach path to landing.

## 8 Training

- 8.1 The operator should ensure that, prior to using the CDFA technique or not (as appropriate), each flight crew member undertakes:
- a. The appropriate training and checking as required by Subpart N. Such training should cover the techniques and procedures appropriate to the operation which are stipulated in paragraphs 4 and 5 of this AC
  - b. The operator's proficiency check should include at least one approach to a landing or go around as appropriate using the CDFA technique or not. The approach should be operated to the lowest appropriate DA (H) or MDA (H) as appropriate; and, if conducted in a Simulator, the approach should be operated to the lowest approved RVR.

Note. The approach required by paragraph 8.1.2 is not in addition to any maneuver currently required by either JCAR FCL or JCAR OPS 1. The requirement may be fulfilled by undertaking any currently required approach (engine out or otherwise) other than a precision approach, whilst using the CDFA technique.

- 8.2 The policy for the establishment of constant predetermined vertical path and approach stability are to be enforced both during initial and recurrent pilot training and checking. The relevant training procedures and instructions should be documented in the OM.
- 8.3 The training should emphasize the need to establish and facilitate joint crew procedures and CRM to enable accurate descent path control and the requirement to establish the airplane in a stable condition as required by the operator's operational procedures. If barometric vertical navigation is used the crews should be trained in the errors associated with these systems.
- 8.4 During training emphasis should be placed on the flight crew's need to:
  - a. Maintain situational awareness at all times, in particular with reference to the required vertical and horizontal profile;
  - b. Ensure good communication channels throughout the approach;
  - c. Ensure accurate descent-path control particularly during any manually-flown descent phase. The non-operating/non-handling pilot should facilitate good flight path control by:
    - i. Communicating any altitude/height crosschecks prior to the actual passing of the range/altitude or height crosscheck;
    - ii. Prompting, as appropriate, changes to the target ROD;
    - iii. Monitoring flight path control below DA/MDA.
  - d. Understand the actions to be taken if the MAPt is reached prior to the MDA (H).
  - e. Ensure that the decision to go around must, at the latest, have been taken upon reaching the DA (H) or MDA (H).

- f. Ensure that prompt go around action is taken immediately when reaching DA(H) if the required visual reference has not been obtained as there may be no obstacle protection if the go-around maneuver is delayed.
  - g. Understand the significance of using the CDFA technique to a DA (H) with an associated MAPt and the implications of early go around maneuvers.
  - h. Understand the possible loss of the required visual reference (due to pitch-change/climb) when not using the CDFA technique for airplane types/classes which require a late change of configuration and/or speed to ensure the airplane is in the appropriate landing configuration.
- 8.5 Additional specific training when not using the CDFA technique with level flight at or above MDA (H).
- a. The training should detail:
    - i. The need to facilitate good CRM; with good flight-crew communication in particular.
    - ii. The additional known safety risks associated with the ‘dive-and-drive’ approach philosophy which may be associated with non-CDFA.
    - iii. The use of DA (H) during approaches flown using the CDFA technique.
    - iv. The significance of the MDA (H) and the MAPt where appropriate.
    - v. The actions to be taken at the MAPt and the need to ensure the airplane remain in a stable condition and on the nominal and appropriate vertical profile until the landing.
    - vi. The reasons for increased RVR/Visibility minima when compared to the application of CDFA.

- vii. The possible increased obstacle infringement risk when undertaking level flight at MDA (H) without the required visual references.
- viii. The need to accomplish a prompt go around maneuver if the required visual reference is lost.
- ix. The increased risk of an unstable final approach and an associated unsafe landing if a rushed approach is attempted either from:
  - a. Inappropriate and close-in acquisition of the required visual reference;
  - b. Unstable airplane energy and or flight path control.
- x. The increased risk of CFIT (See introduction).

## 9 Approvals

- 9.1 The procedures which are flown with level flight at/or above MDA (H) must be approved by CARC and listed in the OM.
- 9.2 Operators should classify aerodromes where there are approaches which require level flight at/or above MDA (H) as being B and C categorized. Such aerodrome categorization will depend upon the operator's experience, operational exposure, training program(s) and flight crew qualification(s).
- 9.3 Exemptions granted in accordance with JCAR OPS 1.430, paragraph (d)(2) should be limited to locations where there is a clear public interest to maintain current operations. The exemptions should be based on the operators experience, training program and flight crew qualification. The exemptions should be reviewed at regular intervals and should be terminated as soon as facilities are improved to allow SAp or CDFA.

## **AMC OPS 1.430(b) (4)**

### **Effect on Landing Minima of temporarily failed or downgraded Ground Equipment**

See JCAR OPS 1.430(b) (4)

1. Introduction
  - 1.1. This AMC provides operators with instructions for flight crews on the effects on landing minima of temporary failures or downgrading of ground equipment.
  - 1.2. Aerodrome facilities are expected to be installed and maintained to the standards prescribed in ICAO Annexes 10 and 14. Any deficiencies are expected to be repaired without unnecessary delay.
2. General. These instructions are intended for use both pre-flight and in-flight. It is not expected however that the commander would consult such instructions after passing the outer marker or equivalent position. If failures of ground aids are announced at such a late stage, the approach could be continued at the commander's discretion. If, however, failures are announced before such a late stage in the approach, their effect on the approach should be considered as described in Tables 1A and 1B below, and the approach may have to be abandoned to allow this to happen.
3. Operations with no Decision Height (DH)
  - 1.1. An operator should ensure that, for airplanes authorized to conduct no DH operations with the lowest RVR limitations, the following applies in addition to the content of Tables 1A and 1B, below:
    - i. RVR. At least one RVR value must be available at the aerodrome;
    - ii. Runway lights
      - a. No runway edge lights, or no centre lights – Day – RVR 200 m; Night – Not allowed.
      - b. No TDZ lights – No restrictions;
      - c. No standby power to runway lights – Day – RVR 200 m; Night – not allowed.

4. Conditions applicable to Tables 1A & 1B
  - i. Multiple failures of runway lights other than indicated in Table 1B are not acceptable.
  - ii. Deficiencies of approach and runway lights are treated separately.
  - iii. Category II or III operations. A combination of deficiencies in runway lights and RVR assessment equipment is not allowed.
  - iv. Failures other than ILS affect RVR only and not DH.



**TABLE 1A - Failed or downgraded equipment - effect on landing minima**

FAILED OR DOWNGRADED EQUIPMENT	EFFECT ON LANDING MINIMA			
	CAT III B (Note 1)	CAT III A	CAT II	CAT I
ILS stand-by transmitter	Not allowed		No effect	
Outer Marker	No effect if replaced by published equivalent position			Not applicable
Middle Marker	No effect			No effect unless used as MAPT
Touch Down Zone RVR assessment system	May be temporarily replaced with midpoint RVR if approved by the State of the aerodrome. RVR may be reported by human observation		No effect	
Midpoint or Stopend RVR	No effect			
Anemometer for RW in use	No effect if other ground source available			
Celiometer	No effect			

Note 1 For Cat III B operations with no DH, see also paragraph 3, above.

**TABLE 1B - Failed or downgraded equipment - effect on landing minima**

FAILED OR DOWNGRADED EQUIPMENT	EFFECT ON LANDING MINIMA			
	CAT III B (Note 1)	CAT III A	CAT II	CAT I
NON PRECISION				
Approach lights	Not allowed for operations with DH > 50 ft		Not allowed	Minima as for nil facilities
Approach lights except the last 210 m	No effect		Not allowed	Minima as for nil facilities
Approach lights except the last 420 m	No effect	No effect		Minima as for intermediate facilities
Standby power for approach lights	No effect			No effect
Whole runway light system	Not allowed			Day - Minima as for nil facilities Night - Not allowed
Edge lights			Day only; Night - not allowed	
Centreline lights	Day - RVR 300 m Night - not allowed		Day - RVR 300 m Night - 550 m	No effect
Centreline lights spacing increased to 30 m	RVR 150 m			No effect
Touch Down Zone lights	Day - RVR 200 m Night - 300 m		Day - RVR 300 m Night - 550 m	No effect
Standby power for runway lights	Not allowed			No effect
Taxiway light system	No effect - except delays due to reduced movement rate			

Note 1 For Cat III B operations with no DH, see also paragraph 3, above.

## **IEM OPS 1.430**

### **Documents containing information related to All Weather Operations**

See JCAR OPS 1, Subpart E

1. The purpose of this IEM is to provide operators with a list of documents related to AWO.
  - a. ICAO Annex 2 / Rules of the Air;
  - b. ICAO Annex 6 / Operation of Aircraft, Part I;
  - c. ICAO Annex 10 / Telecommunications Vol 1;
  - d. ICAO Annex 14 / Aerodromes Vol 1;
  - e. ICAO Doc 8186 / PANS - OPS Aircraft Operations;
  - f. ICAO Doc 9365 / AWO Manual;
  - g. ICAO Doc 9476 / SMGCS Manual (Surface Movement Guidance and Control Systems);
  - h. ICAO Doc 9157 / Aerodrome Design Manual;
  - i. ICAO Doc 9328 / Manual for RVR Assessment;
  - j. ECAC Doc 17, Issue 3 (partly incorporated in JCAR OPS); and
  - k. JCAR-AWO (Airworthiness Certification).

## **AC OPS to Appendix 1 to JCAR–OPS 1.430(d) Aerodrome Operating Minima**

### **Determination of RVR / Visibility Minima for Category I, APV and non-precision approaches**

1. Introduction
  - 1.1 The minimum RVR values for the conduct of Category I, APV and non-precision approaches shall be the higher of the values derived from Table 5 or 6 of Appendix 1 to JCAR OPS 1.430(d).
  - 1.2 The tables are to be used for the determination of all applicable operational RVR values except as prescribed in paragraph 1.3 below.
  - 1.3 With the approval of CARC, the formula below may be used with the actual approach slope and or the actual length of the approach lights for a particular runway. This formula may also be used with the approval of CARC to calculate the applicable RVR for special (one-off) approach operations which are allowed under JCAR OPS 1.430 paragraph (d) (4).
  - 1.4 When the formula is utilized as described above, the calculation conventions and methodologies described in the notes applicable to Paragraph 2 below should be used.
2. Derivation of Minimum RVR Values.
  - 2.1 The values in Table 5 in Appendix 1 to JCAR OPS 1.430(d) are derived from the formula below:

$$\text{Required RVR/Visibility (m)} = \frac{\text{DH/MDH (ft)} \times 0.3048}{\tan \alpha} - \text{length of approach lights (m)}$$

Note 1.  $\alpha$  is the calculation angle, being a default value of 3.00 degrees increasing in steps of 0.10 degrees for each line in Table 5 up to 3.77 degrees and then remains constant.

Note 2. The default value for the length of the approach lights is equal to the minimum length of the various systems described in Table 4 in Appendix 1 to JCAR OPS 1.430(d).

Note 3. The values derived from the above formula have been rounded to the nearest 50 meters up to a value of 800 meters RVR and thereafter to the nearest 100 meters.

Note 4. The DH/MDH intervals in Table 5 have been selected to avoid anomalies caused by the rounding of the calculated OCA (H).

Note 5. The height intervals, referred in Note 4 above, are 10 feet up to a DH/MDH of 300 feet, 20 feet up to a DH/MDH of 760 feet and then 50 feet for DH/MDH above 760 feet.

Note 6. The minimum value of the table is 550 meters.

- 2.2 With the approval of CARC, the formula may be used to calculate the applicable RVR value for approaches with approach-slopes of greater than 4.5 degrees.
3. Approach Operations with an RVR of less than 750m (800m for single-pilot operations)
  - 3.1 Providing the DH is not more than 200 ft, approach operations are almost unrestricted with a runway which is equipped with FALS, RTZL and RCLL. Under these circumstances, the applicable RVR of less than 750m (800m for single-pilot operations) may be taken directly from Table 5. The ILS should not be promulgated as restricted in AIPs, NOTAMS or other documents. Unacceptable ILS restrictions would include limitations on the use of the localizer and / or glide slope below a certain height, prohibitions on its use auto-coupled or limitations on the ILS classification.
  - 3.2 Without RTZL and RCLL in order to be able to operate to the RVR values of less than 750m (800m for single-pilot operations) in Table 5, the approach must be conducted utilizing an approved HUDLS (or equivalent approved system), or be flown as a coupled approach or flight-director-flown approach (Note: not for single-pilot operations) to a DH of not greater than 200 ft. The equivalent system could for instance be an approved HUD which is not certificated as a landing system but is able to provide adequate guidance cues. Other devices may also be suitable, such as Enhanced/Synthetic Vision Systems (E/SVS) or other hybrids of such devices.

4. Description of Approach Lighting Systems

4.1 The following table describes the types of approach lighting systems which are acceptable for calculation of the aerodrome operating minima. The systems described are basically the ICAO systems as described in Annex 14. However, the table also contains shorter systems which are acceptable for operational use. This is concurrent with the fact that approach lighting systems may sometimes be adjusted to the conditions existing before the threshold. Additionally the table describes the FAA approach lighting systems which are considered to be corresponding for calculation of aerodrome operating minima.

JCAR OPS Class of Facility	Length, configuration and intensity of approach lights
FALS (Full Approach Light System)	Precision approach category I lighting system as specified in Annex 14, high intensity lights, 720 m or more FAA: ALSF1, ALSF2, SSALR, MALSR, high or medium intensity and/or flashing lights, 720 m or more
IALS (Intermediate Approach Light System)	JAA: Simplified Approach Light System as specified in Annex 14, high intensity lights, 420 – 719 m FAA: MALSF, MALS, SALS/SALSF, SSALF, SSALS, high or medium intensity and/or flashing lights, 420 – 719 m
BALS (Basic Approach Light System)	JAA: High, medium or low intensity lights, 210 - 419 m including one crossbar FAA: ODALS, high or medium intensity or flashing lights 210 - 419 m
NALS (No Approach Light System)	JAA: Approach Light System shorter than 210 m or no approach lights

**IEM to Appendix 1 to JCAR OPS 1.430, paragraphs (f) and (g)  
Establishment of minimum RVR for Category II and III Operations**

See Appendix 1 to JCAR OPS 1.430, paragraphs (f) and (g)

1. General

1.1 When establishing minimum RVR for Category II and III Operations, operators should pay attention to the following information which originates in ECAC Doc 17 3rd Edition, Subpart A. It is retained as background information and, to some extent, for historical purposes although there may be some conflict with current practices.

1.2 Since the inception of precision approach and landing operations various methods have been devised for the calculation of aerodrome operating minima in terms of decision height and runway visual range. It is a comparatively straightforward matter to establish the decision height for an operation but establishing the minimum RVR to be associated with that decision height so as to provide a high probability that the required visual reference will be available at that decision height has been more of a problem.

1.3 The methods adopted by various States to resolve the DH/RVR relationship in respect of Category II and Category III operations have varied considerably. In one instance there has been a simple approach which entailed the application of empirical data based on actual operating experience in a particular environment. This has given satisfactory results for application within the environment for which it was developed. In another instance a more sophisticated method was employed which utilized a fairly complex computer program to take account of a wide range of variables. However, in the latter case, it has been found that with the improvement in the performance of visual aids, and the increased use of automatic equipment in the many different types of new aircraft, most of the variables cancel each other out and a simple tabulation can be constructed which is applicable to a wide range of aircraft. The basic principles which are observed in establishing the values in such a table are that the scale of visual reference required by a pilot at and below decision height depends on the task that he has to carry out, and that the degree to which his vision is obscured depends on the obscuring medium, the general rule in fog being that it becomes more dense with increase in height. Research using flight simulators coupled with flight trials has shown the following:

- a. Most pilots require visual contact to be established about 3 seconds above decision height though it has been observed that this reduces to about 1 second when a fail-operational automatic landing system is being used;
- b. To establish lateral position and cross-track velocity most pilots need to See not less than a 3 light segment of the centre line of the approach lights, or runway centre line, or runway edge lights;
- c. For roll guidance most pilots need to See a lateral element of the ground pattern, i.e. an approach lighting cross bar, the landing threshold, or a barrette of the touchdown zone lighting; and
- d. To make an accurate adjustment to the flight path in the vertical plane, such as a flare, using purely visual cues, most pilots need to See a point on the ground which has a low or zero rate of apparent movement relative to the aircraft.

- e. With regard to fog structure, data gathered in the United Kingdom over a twenty-year period have shown that in deep stable fog there is a 90% probability that the slant visual range from eye heights higher than 15ft above the ground will be less than the horizontal visibility at ground level, i.e. RVR. There are at present no data available to show what the relationship is between the Slant Visual Range and RVR in other low visibility conditions such as blowing snow, dust or heavy rain, but there is some evidence in pilot reports that the lack of contrast between visual aids and the background in such conditions can produce a relationship similar to that observed in fog.

## 2. Category II Operations

### 2.1 The selection of the dimensions of the required visual segments which are used for Category II operations is based on the following visual requirements:

- a. A visual segment of not less than 90 meters will need to be in view at and below decision height for pilot to be able to monitor an automatic system;
- b. A visual segment of not less than 120 meters will need to be in view for a pilot to be able to maintain the roll attitude manually at and below decision height; and
- c. For a manual landing using only external visual cues, a visual segment of 225 meters will be required at the height at which flare initiation starts in order to provide the pilot with sight of a point of low relative movement on the ground.

## 3. Category III fails passive operations

### 3.1 Category III operations utilizing fail-passive automatic landing equipment were introduced in the late 1960's and it is desirable that the principles governing the establishment of the minimum RVR for such operations be dealt with in some detail.



- 3.2 During an automatic landing the pilot needs to monitor the performance of the aircraft system, not in order to detect a failure which is better done by the monitoring devices built into the system, but so as to know precisely the flight situation. In the final stages he should establish visual contact and, by the time he reaches decision height, he should have checked the aircraft position relative to the approach or runway centre-line lights. For this he will need sight of horizontal elements (for roll reference) and part of the touchdown area. He should check for lateral position and cross-track velocity and, if not within the pre-stated lateral limits, he should carry out a go-around. He should also check longitudinal progress and sight of the landing threshold is useful for this purpose, as is sight of the touchdown zone lights.
- 3.3 In the event of a failure of the automatic flight guidance system below decision height, there are two possible courses of action; the first is a procedure which allows the pilot to complete the landing manually if there is adequate visual reference for him to do so, or to initiate a go-around if there is not; the second is to make a go-around mandatory if there is a system disconnect regardless of the pilot's assessment of the visual reference available.
- a. If the first option is selected then the overriding requirement in the determination of a minimum RVR is for sufficient visual cues to be available at and below decision height for the pilot to be able to carry out a manual landing. Data presented in Doc 17 showed that a minimum value of 300 meters would give a high probability that the cues needed by the pilot to assess the aircraft in pitch and roll will be available and this should be the minimum RVR for this procedure
  - b. The second option, to require a go-around to be carried out should the automatic flight-guidance system fail below decision height, will permit a lower minimum RVR because the visual reference requirement will be less if there is no need to provide for the possibility of a manual landing. However, this option is only acceptable if it can be shown that the probability of a system failure below decision height is acceptably low. It should be recognized that the inclination of a pilot who experiences such a failure would be to continue the landing manually but the results of flight trials in actual conditions and of simulator experiments show that pilots do not always recognize that the visual cues are inadequate in such situations and present recorded data reveal that pilots' landing performance reduces progressively as the RVR is reduced below 300 meters.

It should further be recognized that there is some risk in carrying out a manual go-around from below 50ft in very low visibility and it should therefore be accepted that if an RVR lower than 300 meters is to be authorized, the flight deck procedure should not normally allow the pilot to continue the landing manually in such conditions and the airplane system should be sufficiently reliable for the go around rate to be low.

- 3.4 These criteria may be relaxed in the case of an aircraft with a fail-passive automatic landing system which is supplemented by a head-up display which does not qualify as a fail-operational system but which gives guidance which will enable the pilot to complete a landing in the event of a failure of the automatic landing system. In this case it is not necessary to make a go-around mandatory in the event of a failure of the automatic landing system when the RVR is less than 300 meters.
4. Category III fails operational operations - with a Decision Height
  - 4.1 For Category III operations utilizing a fail-operational landing system with a Decision Height, a pilot should be able to See at least 1 centre line light.
  - 4.2 For Category III operations utilizing a fail-operational hybrid landing system with a Decision Height, a pilot should have a visual reference containing a segment of at least 3 consecutive lights of the runway centre line lights.
5. Category III fails operational operations - with No Decision Height
  - 5.1 For Category III operations with No Decision Height the pilot is not required to See the runway prior to touchdown. The permitted RVR is dependent on the level of airplane equipment.
  - 5.2 A CAT III runway may be assumed to support operations with no Decision Height unless specifically restricted as published in the AIP or NOTAM.

**IEM to Appendix 1 to JCAR OPS 1.430, paragraph (g) (5) - Table 8**  
**Crew actions in case of autopilot failure at or below decision height in fail-passive Category III operations**

See Appendix 1 to JCAR OPS 1.430, paragraph (g) (5) Table 8

For operations to actual RVR values less than 300m, a go-around is assumed in the event of an autopilot failure at or below DH.

This means that a go-around is the normal action. However the wording recognizes that there may be circumstances where the safest action is to continue the landing. Such circumstances include the height at which the failure occurs, the actual visual references, and other malfunctions. This would typically apply to the late stages of the flare.

In conclusion it is not forbidden to continue the approach and complete the landing when the commander or the pilot to whom the conduct of the flight has been delegated, determines that this is the safest course of action.

Operational instructions should reflect the information given in this IEM and the operators' policy.

**AC OPS to Appendix 1 to JCAR OPS 1.430(h)**  
**Aerodrome operating minima**  
**Enhanced vision system**

1. Introduction

1.1 Enhanced vision systems use sensing technology to improve a pilot's ability to detect objects, such as runway lights or terrain, which may otherwise not be visible. The image produced from the sensor and/or image processor can be displayed to the pilot in a number of ways including use of a head up display. The systems can be used in all phases of flight and can improve situational awareness. In particular, infrared systems can display terrain during operations at night, improve situational awareness during night and low visibility taxiing, and may allow earlier acquisition of visual references during instrument approaches.

## 2. Background to EVS rule

- 2.1 The rule for EVS was developed after an operational evaluation of two different EVS systems, along with data and support kindly provided by the FAA. Approaches using EVS were flown in a variety of conditions including fog, rain and snow showers, as well as at night to aerodromes located in mountainous terrain. The infrared EVS performance can vary depending on the weather conditions encountered. Therefore, the Rule takes a conservative approach to cater for the wide variety of conditions which may be encountered. It may be necessary to amend the Rule in future to take account of greater operational experience.
- 2.2 A rule for the use of EVS during takeoff has not been developed. The systems evaluated did not perform well when the RVR was below 300 meters. There may be some benefit for use of EVS during takeoff with greater visibility and reduced lighting; however, such operations would need to be evaluated.
- 2.3. The Rule has been developed to cover use of infrared systems only. Other sensing technologies are not intended to be excluded; however, their use will need to be evaluated to determine the appropriateness of this, or any other rule. During the development of the Rule material in JCAR OPS 1.430 (h), it was envisaged what equipment should be fitted to the airplane, as a minimum. Given the present state of technological development, it is considered that a HUD is an essential element of the EVS equipment.
- 2.4. In order to avoid the need for tailored charts for approaches utilizing EVS, it is envisaged that an operator will use Table 9 to determine the applicable RVR at the commencement of the approach.

## 3 Additional Operational requirements

- 3.1. An enhanced vision system equipment certificated for the purpose of Appendix 1 to JCAR OPS 1.403(h) should have:
  - a. A head up display system (capable of displaying, airspeed, vertical speed, aircraft attitude, heading, altitude, command guidance as appropriate for the approach to be flown, path deviation indications, flight path vector, and flight path angle reference cue and the EVS imagery),

- b. For two-pilot operation, a head-down view of the EVS image, or other means of displaying the EVS-derived information easily to the pilot monitoring the progress of the approach.

Note: If the aircraft is equipped with a radio altimeter, it will be used only as enhanced terrain awareness during approach using EVS and will be not taken into account for the operational procedures development

#### 4 Two-pilot operations

- 4.1. For operations in RVRs below 550 m, two-pilot operation will be required.
- 4.2. The requirement for a head-down view of the EVS image is intended to cover for multi-pilot philosophy, whereby the pilot not-flying (PNF) is kept in the 'loop' and CRM does not break down. The PNF can be very isolated from the information necessary for monitoring flight progress and decision making if the PF is the only one to have the EVS image.

### **AC to Appendix 1 to JCAR OPS 1.430, paragraph (j) Terminology: XLS= ILS/MLS/GLS etc**

#### **Visual Maneuvering (circling)**

1. The purpose of this AC is to provide operators with supplemental information regarding the application of aerodrome operating minima in relation to circling approaches
2. Conduct of flight – General
  - 2.1 The Minimum Descent Height (MDH) and Obstacle Clearance Height (OCH) included in the procedure are referenced to aerodrome elevation.
  - 2.2 The Minimum Descent Altitude (MDA) is referenced to mean sea level.
  - 2.3 For these procedures, the applicable visibility is the meteorological visibility (VIS).

3. Instrument approach followed by visual maneuvering (circling) without prescribed tracks
  - 3.1 When the airplane is on the initial instrument approach, before visual reference is stabilized, but not below MDH/MDA - the airplane should follow the corresponding instrument approach procedure until the appropriate instrument Missed Approach Point (MAPt) is reached.
  - 3.2 At the beginning of the level flight phase at or above the MDH/MDA, the instrument approach track determined by radio navigation aids, RNAV, RNP or XLS should be maintained until:
    - a. The pilot estimates that, in all probability, visual contact with the runway of intended landing or the runway environment will be maintained during the entire circling procedure; and
    - b. The pilot estimates that the airplane is within the circling area before commencing circling; and
    - c. The pilot is able to determine the airplane's position in relation to the runway of intended landing with the aid of the appropriate external references.
  - 3.3 When reaching the published instrument MAPt and the conditions stipulated in paragraph 3.2 above, are unable to be established by the pilot, a missed approach should be carried out in accordance with that instrument approach procedure. See paragraph 5.
  - 3.4 After the airplane has left the track of the initial (letdown) instrument approach, the flight phase outbound from the runway should be limited to an appropriate distance, which is required to align the airplane onto the final approach. Such maneuvers should be conducted to enable the airplane:
    - a. To attain a controlled and stable descent path to the intended landing runway; and
    - b. Remain within the circling area and in such way that visual contact with the runway of intended landing or runway environment is maintained at all times.

- 3.5 Flight maneuvers should be carried out at an altitude/height that is not less than the circling MDH/MDA.
- 3.6 Descent below MDH/MDA should not be initiated until the threshold of the runway to be used has been appropriately identified and the airplane is in a position to continue with a normal rate of descent and land within the touchdown zone.
4. Instrument approach followed by a visual maneuvering (circling) with prescribed track
  - 4.1 The airplane should remain on the initial instrument approach or letdown procedure until one of the following is reached:
    - a. The prescribed divergence point to commence circling on the prescribed track; or
    - b. The appropriate initial instrument MAPt.
  - 4.2 The airplane should be established on the instrument approach track determined by the radio navigation aids, RNAV, RNP, or XLS in level flight at or above the MDH/MDA at or by the circling maneuver divergence point.
  - 4.3 If the divergence point is reached before the required visual reference is acquired, a missed approach should be initiated not later than the initial instrument approach MAPt and completed in accordance with the initial instrument approach procedure.
  - 4.4. When commencing the prescribed track-circling maneuver at the published divergence point, the subsequent maneuvers should be conducted to comply with the published routing and promulgated heights/altitudes.
  - 4.5 Unless otherwise specified, once the airplane is established on the prescribed track(s), the promulgated visual reference should not be required to be maintained unless:
    - a. Required by CARC;
    - b. The Circling MAPt (if published) is reached.

- 4.6 If the prescribed track-circling maneuver has a published MAPt and the required visual reference has not been obtained a missed approach should be executed in accordance with paragraphs 5.2 and 5.3 below.
  - 4.7. Subsequent further descent below MDH/MDA should only commence when the required visual reference is obtained.
  - 4.8. Unless otherwise specified in the procedure, final descent should not be initiated from MDH/MDA until the threshold of the intended landing runway has been appropriately identified and the airplane is in a position to continue with a normal rate of descent and land within the touchdown zone.
- 5 Missed approach
- 5.1 Missed Approach during Instrument Approach prior to Circling
    - a. If the decision to carry out a missed approach is taken when the airplane is positioned on the instrument approach track defined by radio-navigation aids RNAV, RNP, or XLS, and before commencing the circling maneuver, the published missed approach for the instrument approach should be followed.
    - b. If the instrument approach procedure is carried out with the aid of an XLS or Stabilized Approach (SAp), the (MAPt) associated with an XLS procedure without glide path (GP out procedure) or the SAp, where applicable, should be used.
  - 5.2 If a prescribed missed approach is published for the circling maneuver, this overrides the maneuvers prescribed below.
  - 5.3 If visual reference is lost while circling to land after the airplane has departed from the initial instrument approach track, the missed approach specified for that particular instrument approach should be followed. It is expected that the pilot will make an initial climbing turn toward the intended landing runway and continue overhead the aerodrome where the pilot will establish the airplane in a climb on the instrument missed approach track.



- 5.4 The airplane should not leave the visual maneuvering (circling) area, which is obstacle protected, unless:
- a. Established on the appropriate missed approach track; or
  - b. At Minimum Sector Altitude (MSA)
- 5.5 All turns should (See Note 1 below) be made in the same direction and the airplane should remain within the circling protected area while climbing to either:
- a. The altitude assigned to any published circling missed approach maneuver if applicable;
  - b. The altitude assigned to the missed approach of the initial instrument approach;
  - c. The Minimum Sector Altitude (MSA);
  - d. The Minimum Holding Altitude (MHA) applicable for transition to a holding facility or fix, or continue to climb to a Minimum Safe Altitude; or
  - e. As directed by ATS (C).

Note 1. When the go-around is commenced on the “downwind” leg of the circling maneuver, an “S” turn may be undertaken to align the airplane on the initial instrument approach missed approach path, provided the airplane remains within the protected circling area.

Note 2. The commander should be responsible for ensuring adequate terrain clearance during the above-stipulated maneuvers, particularly during the execution of a missed approach initiated by ATS.

- 5.6 In as much as the circling maneuver may be accomplished in more than one direction, different patterns will be required to establish the airplane on the prescribed missed approach course depending on its position at the time visual reference is lost. In particular, all turns are to be in the prescribed direction if this is restricted, e.g. to the west/east (left or right hand) to remain within the protected circling area.

- 5.7 If a missed approach procedure is promulgated for the runway (XX) onto which the airplane is conducting a circling approach and the airplane has commenced a maneuver to align with the runway; the missed approach for this direction may be accomplished. The ATS should be informed of the intention to fly the promulgated missed approach procedure for runway XX.
- 5.8 When the option described in paragraph 5.7 above is undertaken the commander should whenever possible, advise at the earliest opportunity, the ATS(C) of the intended go around procedure. This dialogue should, if possible occur during the initial approach phase and include the intended missed approach to be flown and the level off altitude.
- 5.9 In addition to 5.8 above, the commander should advise ATS(C) when any go around has commenced the height / altitude the airplane is climbing to and the position the airplane is proceeding towards and or heading the airplane is established on.

## **AC to Appendix 1 to JCAR OPS 1.440**

### **Operational Demonstrations**

See Appendix 1 to JCAR OPS 1.440

1. General
  - 1.1 Demonstrations may be conducted in line operations or any other flight where the Operator's procedures are being used.
  - 1.2 In unique situations where the completion of 100 successful landings could take an unreasonably long period of time due to factors such as a small number of airplanes in the fleet, limited opportunity to use runways having Category II/III procedures, or inability to obtain ATS sensitive area protection during good weather conditions, and equivalent reliability assurance can be achieved, a reduction in the required number of landings may be considered on a case-by-case basis. Reduction of the number of landings to be demonstrated requires a justification for the reduction, and prior approval from CARC. However, at the operator's option, demonstrations may be made on other runways and facilities. Sufficient information should be collected to determine the cause of any unsatisfactory performance (e.g. sensitive area was not protected).

- 1.3 If an operator has different variants of the same type of airplane utilizing the same basic flight control and display systems, or different basic flight control and display systems on the same type/classes of airplane, the operator should show that the various variants have satisfactory performance, but the operator need not conduct a full operational demonstration for each variant.
- 1.4 Not more than 30% of the demonstration flights should be made on the same runway.
2. Data Collection for Operational Demonstrations
  - 2.1 Data should be collected whenever an approach and landing is attempted utilizing the Category II/III system, regardless of whether the approach is abandoned, unsatisfactory, or is concluded successfully.
  - 2.2 The data should, as a minimum, include the following information:
    - a. Inability to initiate an Approach. Identify deficiencies related to airborne equipment which preclude initiation of a Category II/III approach.
    - b. Abandoned Approaches. Give the reasons and altitude above the runway at which approach was discontinued or the automatic landing system was disengaged.
    - c. Touchdown or Touchdown and Roll-out Performance. Describe whether or not the aircraft landed satisfactorily (within the desired touchdown area) with lateral velocity or cross track error which could be corrected by the pilot or automatic system so as to remain within the lateral confines of the runway without unusual pilot skill or technique. The approximate lateral and longitudinal position of the actual touchdown point in relation to the runway centerline and the runway threshold, respectively, should be indicated in the report. This report should also include any Category II/III system abnormalities which required manual intervention by the pilot to ensure a safe touchdown or touchdown and roll-out, as appropriate.

3. Data Analysis

3.1 Unsuccessful approaches due to the following factors may be excluded from the analysis:

- a. **ATS Factors.** Examples include situations in which a flight is vectored too close to the final approach fix/point for adequate localizer and glide slope capture, lack of protection of ILS sensitive areas, or ATS requests the flight to discontinue the approach.
- b. **Faulty Nav.aid Signals.** Nav.aid (e.g. ILS localizer) irregularities, such as those caused by other aircraft taxiing, over-flying the nav.aid (antenna).
- c. **Other Factors.** Any other specific factors that could affect the success of Category II/ III operations that are clearly discernible to the flight crew should be reported.

**IEM to Appendix 1 to JCAR OPS 1.440, paragraph (b)**  
**Criteria for a successful CAT II/III approach and automatic landing**

See Appendix 1 to JCAR OPS 1.440, paragraph (b)

1. The purpose of this IEM is to provide operators with supplemental information regarding the criteria for a successful approach and landing to facilitate fulfilling the requirements prescribed in Appendix 1 to JCAR OPS 1.440, paragraph (b).
2. An approach may be considered to be successful if:
  - 2.1 From 500 feet to start of flare:
    - a. Speed is maintained as specified in AC-AWO 231, paragraph 2 ‘Speed Control’;  
and
    - b. No relevant system failure occurs; and

- 2.2 From 300 feet to DH:
  - a. No excess deviation occurs; and
  - b. No centralized warning gives a go-around command (if installed).
3. An automatic landing may be considered to be successful if:
  - a. No relevant system failure occurs;
  - b. No flare failure occurs;
  - c. No de-crab failure occurs (if installed);
  - d. Longitudinal touchdown is beyond a point on the runway 60 metres after the threshold and before the end of the touchdown zone lighting (900 meters from the threshold);
  - e. Lateral touchdown with the outboard landing gear is not outside the touchdown zone lighting edge;
  - f. Sink rate is not excessive;
  - g. Bank angle does not exceed a bank angle limit; and
  - h. No roll-out failure or deviation (if installed) occurs.
4. More details can be found in JCAR AWO 131, JCAR AWO 321 and AC AWO 231`

### **IEM OPS 1.450(g) (1)**

#### **Low Visibility Operations - Training & Qualifications**

See Appendix 1 to JCAR OPS 1.450

The number of approaches referred to in 1.450(g) (1) includes one approach and landing that may be conducted in the airplane using approved Category II/III procedures. This approach and landing may be conducted in normal line operation or as a training flight. It is assumed that such flights will only be conducted by pilots qualified in accordance JCAR OPS 1.940 and qualified for the particular category of operation.

## **AMC/IEM F Performance General**

### **AMC OPS 1.475(b)**

#### **Landing - Reverse Thrust Credit**

See JCAR OPS 1.475(b)

Landing distance data included in the AFM (or POH etc.) with credit for reverse thrust can only be considered to be approved for the purpose of showing compliance with the applicable requirements if it contains a specific statement from the appropriate airworthiness authority that it complies with a recognized airworthiness code (e.g. JCAR 23/25, FAR 23/25, JAR 23/25, BCAR Section 'D'/'K'.)

### **IEM OPS 1.475(b)**

#### **Factoring of Automatic Landing Distance Performance Data (Performance Class A Airplanes only)**

See JCAR OPS 1.475(b)

1. In those cases where the landing requires the use of an automatic landing system, and the distance published in the Airplane Flight Manual (AFM) includes safety margins equivalent to those contained in JCAR OPS 1.515(a)(1) and JCAR OPS 1.520, the landing mass of the airplane should be the lesser of:
  - a. The landing mass determined in accordance with JCAR OPS 1.515(a) (1); or
  - b. The landing mass determined for the automatic landing distance for the appropriate surface condition as given in the AFM, or equivalent document. Increments due to system features such as beam location or elevations, or procedures such as use of over speed, should also be included.

**AC/AMC/IEM G**  
**Performance Class A**

**IEM OPS 1.485(b)**

**General – Wet and Contaminated Runway data**

See JCAR OPS 1.485(b)

If the performance data has been determined on the basis of measured runway friction coefficient, the operator should use a procedure correlating the measured runway friction coefficient and the effective braking coefficient of friction of the airplane type over the required speed range for the existing runway conditions.

**IEM OPS 1.490(c) (3)**

**Take off – Runway surface condition**

See JCAR OPS 1.490(c) (3)

1. Operation on runways contaminated with water, slush, snow or ice implies uncertainties with regard to runway friction and contaminant drag and therefore to the achievable performance and control of the airplane during take-off, since the actual conditions may not completely match the assumptions on which the performance information is based. In the case of a contaminated runway, the first option for the commander is to wait until the runway is cleared. If this is impracticable, he may consider a take-off, provided that he has applied the applicable performance adjustments, and any further safety measures he considers justified under the prevailing conditions.
2. An adequate overall level of safety will be maintained if operations in accordance with JCAR 25 AM 25X1591 are limited to rare occasions. Where the frequency of such operations on contaminated runways is not limited to rare occasions, operators should provide additional measures ensuring an equivalent level of safety. Such measures could include special crew training, additional distance factoring and more restrictive wind limitation

## **IEM OPS 1.490(c) (6)**

### **Loss of runway length due to alignment**

See JCAR OPS 1.490(c) (6)

#### 1. Introduction

- 1.1 The length of the runway which is declared for the calculation of TODA, ASDA and TORA, does not account for line-up of the airplane in the direction of take-off on the runway in use. This alignment distance depends on the airplane geometry and access possibility to the runway in use. Accountability is usually required for a 90° taxiway entry to the runway and 180° turnaround on the runway. There are two distances to be considered:
- The minimum distance of the main wheels from the start of the runway for determining TODA and TORA, "L"; and
  - The minimum distance of the most forward wheel(s) from the start of the runway for determining ASDA, "N"

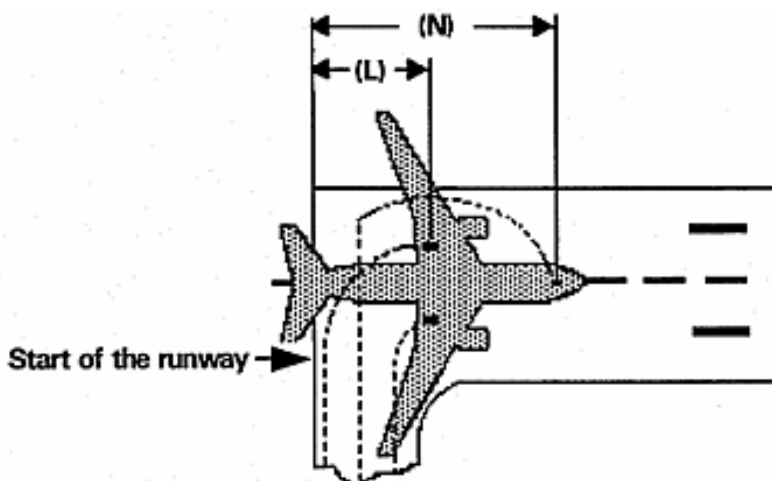

Where the airplane manufacturer does not provide the appropriate data, the calculation method given in paragraph 2 may be use to determine the alignment distance.



2. Alignment Distance Calculation

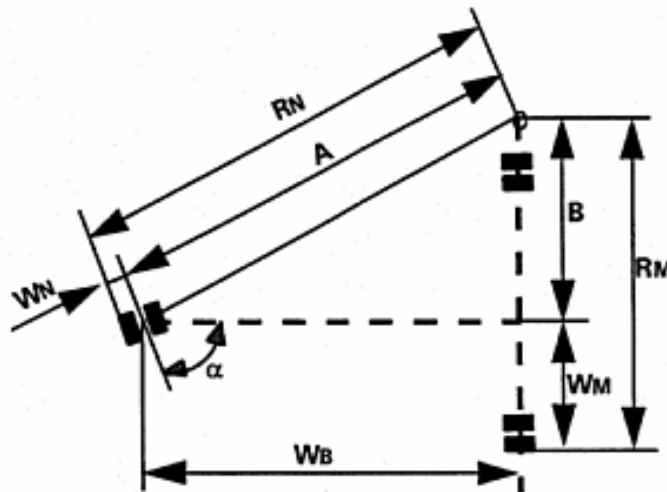

The distances mentioned in (a) and (b) of paragraph 1 above are:

	90° ENTRY	180° TURNAROUND
L=	$R_M + X$	$R_N + Y$
N=	$R_M + X + W_B$	$R_N + Y + W_B$

B where:  $R_N = A + W_N = \frac{A + W_N}{\cos(90^\circ - \alpha)} + W_N$

and  $R_M = B + W_M = W_B \tan(90^\circ - \alpha) + W_M$

X = Safety distance of outer main wheel during turn to the edge of the runway

Y = Safety distance of outer nose wheel during turn to the edge of the runway

NOTE. Minimum edge safety distances for X and Y are specified in FAA AC 150/5300-13 and ICAO Annex 14 paragraph 3.8.3

RN = Radius of turn of outer nose wheel

RM = Radius of turn of outer main wheel

WN = Distance from airplane centre-line to outer nose wheel

WM = Distance from airplane centre-line to outer main wheel

WB = Wheel base

alpha = Steering angle

## **IEM OPS 1.495(a)**

### **Take-off obstacle clearance**

See JCAR OPS 1.495(a)

1. In accordance with the definitions used in preparing the take-off distance and take-off flight path Data provided in the Airplane Flight Manual:
  - a. The net take-off flight path is considered to begin at a height of 35 ft above the runway or clearway at the end of the take-off distance determined for the airplane in accordance with sub-paragraph (b) below.
  - b. The take-off distance is the longest of the following distances:
    - i. 115 % of the distance with all engines operating from the start of the take-off to the point at which the airplane is 35 ft above the runway or clearway; or
    - ii. The distance from the start of the take-off to the point at which the airplane is 35 ft above the runway or clearway assuming failure of the critical engine occurs at the point corresponding to the decision speed (V1) for a dry runway; or
    - iii. If the runway is wet or contaminated, the distance from the start of the take-off to the point at which the airplane is 15 ft above the runway or clearway assuming failure of the critical engine occurs at the point corresponding to the decision speed (V1) for a wet or contaminated runway.

JCAR OPS 1.495(a) specifies that the net take-off flight path, determined from the data provided in the Airplane Flight Manual in accordance with sub-paragraphs 1(a) and 1(b) above, must clear all relevant obstacles by a vertical distance of 35 ft. When taking off on a wet or contaminated runway and an engine failure occurs at the point corresponding to the decision speed (V1) for a wet or contaminated runway, this implies that the airplane can initially be as much as 20 ft below the net take-off flight path in accordance with sub-paragraph 1 above and, therefore, may clear close-in obstacles by only 15 ft. When taking off on wet or contaminated runways, the operator should exercise special care with respect to obstacle assessment, especially if a take-off is obstacle limited and the obstacle density is high.

## **AMC OPS 1.495(c) (4)**

### **Take-off obstacle clearance**

See JCAR OPS 1.495(c)

1. The Airplane Flight Manual generally provides a climb gradient decrement for a 15° bank turn. For bank angles of less than 15°, a proportionate amount should be applied, unless the manufacturer or Airplane Flight Manual has provided other data.
2. Unless otherwise specified in the Airplane Flight Manual or other performance or operating manuals from the manufacturer, acceptable adjustments to assure adequate stall margins and gradient corrections are provided by the following:

<b>Bank</b>	<b>Speed</b>	<b>Gradient Correction</b>
15°	V2	1 x Airplane Flight Manual 15° Gradient Loss
20°	V2 + 5 kt	2 x Airplane Flight Manual 15° Gradient Loss
25°	V2 + 10 kt	3 x Airplane Flight Manual 15° Gradient Loss

## **AMC OPS 1.495(d) (1) & (e) (1)**

### **Required Navigational Accuracy**

See JCAR OPS 1.495(d) (1) & (e) (1)

1. Flight-deck systems. The obstacle accountability semi-widths of 300 m (See JCAR OPS 1.495(d)(1)) and 600 m (See JCAR OPS 1.495(e)(1)) may be used if the navigation system under one-engine-inoperative conditions provides a two standard deviation (2 s) accuracy of 150 m and 300 m respectively.
2. Visual Course Guidance
  - 2.1 The obstacle accountability semi-widths of 300 m (See JCAR OPS 1.495(d)(1)) and 600 m (See JCAR OPS 1.495(e)(1)) may be used where navigational accuracy is ensured at all relevant points on the flight path by use of external references. These references may be considered visible from the flight deck if they are situated more than 45° either side of the intended track and with a depression of not greater than 20° from the horizontal.

- 2.2 For visual course guidance navigation, an operator should ensure that the weather conditions prevailing at the time of operation, including ceiling and visibility, are such that the obstacle and/or ground reference points can be Seen and identified. The Operations Manual should specify, for the aerodrome(s) concerned, the minimum weather conditions which enable the flight crew to continuously determine and maintain the correct flight path with respect to ground reference points, so as to provide a safe clearance with respect to obstructions and terrain as follows:
- a. The procedure should be well defined with respect to ground reference points so that the track to be flown can be analyzed for obstacle clearance requirements;
  - b. The procedure should be within the capabilities of the airplane with respect to forward speed, bank angle and wind effects;
  - c. A written and/or pictorial description of the procedure should be provided for crew use;
  - d. The limiting environmental conditions (such as wind, the lowest cloud base, ceiling, visibility, day/night, ambient lighting, obstruction lighting) should be specified.

### **IEM OPS 1.495(f)**

#### **Engine failure procedures**

See JCAR OPS 1.495(f)

If compliance with JCAR OPS 1.495(f) is based on an engine failure route that differs from the all engine departure route or SID normal departure, a “deviation point” can be identified where the engine failure route deviates from the normal departure route. Adequate obstacle clearance along the normal departure with failure of the critical engine at the deviation point will normally be available. However, in certain situations the obstacle clearance along the normal departure route may be marginal and should be checked to ensure that, in case of an engine failure after the deviation point, a flight can safely proceed along the normal departure.

## **AMC OPS 1.500**

### **En-Route – One Engine Inoperative**

See JCAR OPS 1.500

1. The high terrain or obstacle analysis required for showing compliance with JCAR OPS 1.500 may be carried out in one of two ways, as explained in the following three paragraphs.
2. A detailed analysis of the route should be made using contour maps of the high terrain and plotting the highest points within the prescribed corridor's width along the route. The next step is to determine whether it is possible to maintain level flight with one engine inoperative 1000 ft above the highest point of the crossing. If this is not possible, or if the associated weight penalties are unacceptable, a drift down procedure should be worked out, based on engine failure at the most critical point and clearing critical obstacles during the drift down by at least 2000 ft. The minimum cruise altitude is determined by the intersection of the two drift down paths, taking into account allowances for decision making (See Figure 1). This method is time consuming and requires the availability of detailed terrain maps.
3. Alternatively, the published minimum flight altitudes (Minimum En route Altitude, MEA, or Minimum Off Route Altitude, MORA) may be used for determining whether one engine inoperative level flight is feasible at the minimum flight altitude or if it is necessary to use the published minimum flight altitudes as the basis for the drift down construction (See Figure 1). This procedure avoids a detailed high terrain contour analysis but may be more penalizing than taking the actual terrain profile into account as in paragraph 2.
4. In order to comply with JCAR OPS 1.500(c), one means of compliance is the use of MORA and, with JCAR OPS 1.500(d), MEA provided that the airplane meets the navigational equipment standard assumed in the definition of MEA.

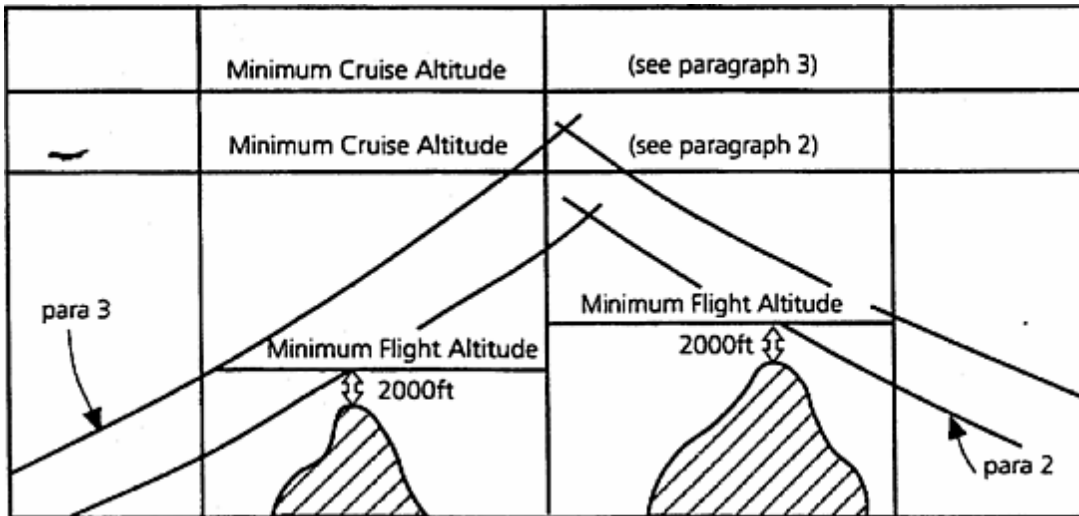

FIGURE 1

NOTE. MEA or MORA normally provides the required 2000 ft obstacle clearance for drift down. However, at and below 6000 ft altitude, MEA and MORA cannot be used directly as only 1000 ft. clearance is ensured.

**IEM OPS 1.510(b) and (c)**

**Landing – Destination and Alternate Aerodromes**

See JCAR OPS 1.510(b) and (c)

The required missed approach gradient may not be achieved by all airplanes when operating at or near maximum certificated landing mass and in engine-out conditions. Operators of such airplanes should consider mass, altitude and temperature limitations and wind for the missed approach. As an alternative method, an increase in the decision altitude/height or minimum descent altitude/height and/or a contingency procedure (See JCAR OPS 1.495(f)) providing a safe route and avoiding obstacles, can be approved.

**AMC OPS 1.510 & 1.515**

**Landing – Destination and Alternate Aerodromes**

**Landing – Dry Runways**

See JCAR OPS 1.510 & 1.515

In showing compliance with JCAR OPS 1.510 and JCAR OPS 1.515, the operator should use either pressure altitude or geometric altitude for his operation and this should be reflected in the Operations Manual.

## **IEM OPS 1.515(c)**

### **Landing – Dry runway**

See JCAR OPS 1.515(c)

1. JCAR OPS 1.515(c) establishes two considerations in determining the maximum permissible landing mass at the destination and alternate aerodromes.
2. Firstly, the airplane mass will be such that on arrival the airplane can be landed within 60% or 70% (as applicable) of the landing distance available on the most favorable (normally the longest) runway in still air. Regardless of the wind conditions, the maximum landing mass for an aerodrome/airplane configuration at a particular aerodrome cannot be exceeded.
3. Secondly, consideration should be given to anticipated conditions and circumstances. The expected wind, or ATC and noise abatement procedures may indicate the use of a different runway. These factors may result in a lower landing mass than that permitted under paragraph 2 above, in which case, to show compliance with JCAR OPS 1.515(a), dispatch should be based on this lesser mass.
4. The expected wind referred to in paragraph 3 is the wind expected to exist at the time of arrival.

## **AMC/IEM H Performance Class B**

### **AMC OPS 1.530(c) (4)**

#### **Take-Off Performance Correction Factors**

See JCAR OPS 1.530(c) (4)

Unless otherwise specified in the Airplane Flight Manual or other performance or operating manuals from the manufacturers, the variables affecting the take-off performance and the associated factors that should be applied to the Airplane Flight Manual data are shown in the table below. They should be applied in addition to the operational factors as prescribed in JCAR OPS 1.530(b).

<b>Surface Type</b>	<b>Condition</b>	<b>Factor</b>
Grass (on firm soil) up to 20 cm long	Dry	1.20
	Wet	1.30
Paved	Wet	1.00

Notes:

1. The soil is firm when there are wheel impressions but no rutting.
2. When taking off on grass with a single engine airplane, care should be taken to assess the rate of acceleration and consequent distance increase.
3. When making a rejected take-off on very short grass which is wet, and with firm subsoil, the surface may be slippery, in which case the distances may increase significantly.

### **IEM OPS 1.530(c) (4)**

#### **Take-Off Performance Correction Factors**

See JCAR OPS 1.530(c) (4)

Due to the inherent risks, operations from contaminated runways are inadvisable, and should be avoided whenever possible. Therefore, it is advisable to delay the take-off until the runway is cleared. Where this is impracticable, the commander should also consider the excess runway length available including the criticality of the overrun area.



## **AMC OPS 1.530(c) (5)**

### **Runway Slope**

See JCAR OPS 1.530(c) (5)

Unless otherwise specified in the Airplane Flight Manual or other performance or operating manuals from the manufacturers, the take-off distance should be increased by 5% for each 1% of upslope except that correction factors for runways with slopes in excess of 2% require the acceptance of CARC.

## **IEM OPS 1.535**

### **Obstacle Clearance in Limited Visibility**

See JCAR OPS 1.535

1. The intent of the complementary requirements JCAR OPS 1.535 and Appendix 1 to JCAR OPS 1.430 sub-paragraph (a)(3)(ii) is to enhance safe operation with Performance Class B airplanes in conditions of limited visibility. Unlike the Performance Class A Airworthiness requirements, those for Performance Class B do not necessarily provide for engine failure in all phases of flight. It is accepted that performance accountability for engine failure need not be considered until a height of 300 ft is reached.
2. The weather minima given in Appendix 1 to JCAR OPS 1.430 sub-paragraph (a)(3)(ii) up to and including 300 ft imply that if a take-off is undertaken with minima below 300 ft a one engine inoperative flight path must be plotted starting on the all-engine take-off flight path at the assumed engine failure height. This path must meet the vertical and lateral obstacle clearance specified in JCAR OPS 1.535. Should engine failure occur below this height, the associated visibility is taken as being the minimum which would enable the pilot to make, if necessary, a forced landing broadly in the direction of the take-off? At or below 300 ft, a circle and land procedure is extremely inadvisable. Appendix 1 to JCAR OPS 1.430 sub-paragraph (a)(3)(ii) specifies that, if the assumed engine failure height is more than 300 ft, the visibility must be at least 1500 m and, to allow for maneuvering, the same minimum visibility should apply whenever the obstacle clearance criteria for a continued take-off cannot be met.

## **AMC OPS 1.535(a)**

### **Take-off Flight Path Construction**

See JCAR OPS 1.535(a)

1. Introduction. For demonstrating that an airplane clears all obstacles vertically, a flight path should be constructed consisting of an all-engine segment to the assumed engine failure height, followed by an engine-out segment. Where the Airplane Flight Manual does not contain the appropriate data, the approximation given in paragraph 2 below may be used for the all-engine segment for an assumed engine failure height of 200 ft, 300 ft, or higher.
2. Flight Path Construction
  - 2.1 All-Engines Segment (50 ft to 300 ft). The average all-engines gradient for the all-engines flight path segment starting at an altitude of 50 ft at the end of the take-off distance ending at or passing through the 300 ft point is given by the following formula:

$$Y_{300} = \frac{0.57(Y_{ERC})}{1 + (V_{ERC}^2 - V_2^2) / 5647}$$

NOTE. The factor of 0.77 as required by JCAR OPS 1.535(a) (4) is already included where:

Y300	=	Average all-engines gradient from 50 ft to 300 ft
YERC	=	Scheduled all engines en-route gross climb gradient
VERC	=	En-route climb speed, all engines knots TAS
V2	=	Take-off speed at 50 ft, knots TAS

(See IEM OPS 1.535(a), Figure 1a for graphical presentation)

- 2.2. All-Engines Segment (50 ft to 200 ft). (May be used as an alternative to 2.1 where weather minima permits) The average all-engine gradient for the all-engine flight path segment starting at an altitude of 50 ft at the end of the take-off distance ending at or passing through the 200 ft point is given by the following formula:

$$Y_{200} = \frac{0.51(Y_{ERC})}{1 + (V_{ERC}^2 - V_2^2) / 3388}$$

NOTE. The factor of 0.77 as required by JCAR OPS 1.535(a) (4) is already included where:

Y200 = Average all-engines gradient from 50 ft to 200 ft

YERC = Scheduled all engines en-route gross climb gradient

VERC = En-route climb speed, all engines, knots TAS

V2 = Take-off speed at 50 ft, knots TAS

(See IEM OPS 1.535(a), Figure 1b for graphical presentation)

- 2.3. All-Engines Segment (above 300 ft). The all-engines flight path segment continuing from an altitude of 300 ft is given by the AFM en-route gross climb gradient, multiplied by a factor of 0.77.
  - 2.4. The One Engine Inoperative Flight Path. The one engine inoperative flight path is given by the one engine inoperative gradient chart contained in the AFM.
- 3 Worked examples of the method given above are contained in IEM OPS 1.535(a).

**IEM OPS 1.535(a)**

**Take-off flight path construction**

See JCAR OPS 1.535(a)

1. This IEM provides examples to illustrate the method of take-off flight path construction given in AMC OPS 1.535(a). The examples shown below are based on an airplane for which the Airplane Flight Manual shows, at a given mass, altitude, temperature and wind component the following performance data:

- Factored take-off distance – 1000 m
- Take-off speed, V2 – 90 kt
- En-route climbs speed, VERC – 120 kt
- En-route all-engine climb gradient, YERC – 0.200
- En-route one engine inoperative climb gradient, YERC-1 – 0.032

a. Assumed Engine Failure Height 300 ft. The average all-engine gradient from 50 ft to 300 ft may be read from Figure 1a (page 147) or calculated with the following formula:

$$Y_{300} = \frac{0.57(Y_{ERC})}{1 + (V_{ERC}^2 - V_2^2) / 5647}$$

NOTE. The factor of 0.77 as required by JCAR OPS 1.535(a) (4) is already included where:

- Y300 = Average all-engines gradient from 50 ft to 300 ft
- YERC = Scheduled all engines en-route gross climb gradient
- VERC = En-route climb speed, all engines knots TAS
- V2 = Take-off speed at 50 ft, knots TAS

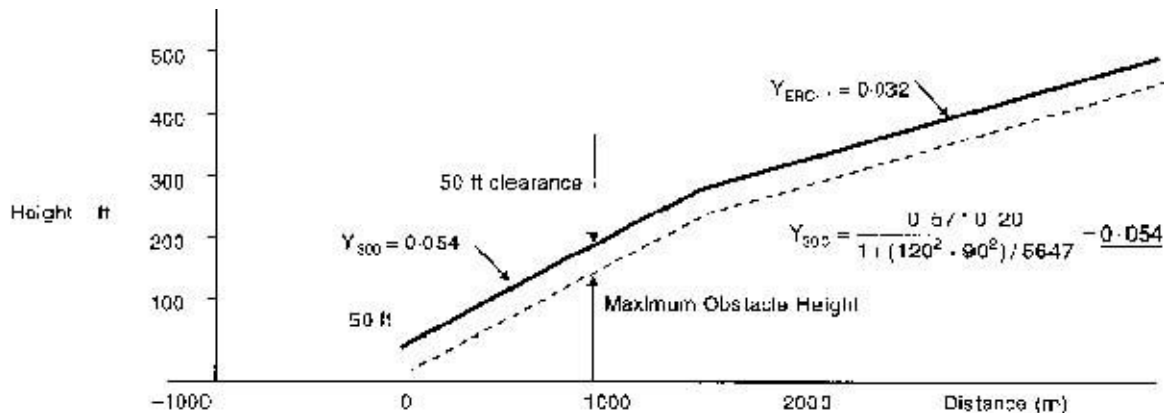

- b. Assumed engine failure height 200 ft. The average all-engine gradient from 50 ft to 200 ft may be read from Figure 1b (page 148) or calculated with the following formula:

$$Y_{200} = \frac{0.51(Y_{ERC})}{1 + (V_{ERC}^2 - V_2^2) / 3388}$$

NOTE. The factor of 0.77 as required by JCAR OPS 1.535(a) (4) is already included where:

Y<sub>200</sub> = Average all-engines gradient from 50 ft to 200 ft

Y<sub>ERC</sub> = Scheduled all engines en-route gross gradient

V<sub>ERC</sub> = En-route climb speed, all engines, knots TAS

V<sub>2</sub> = Take-off speed at 50 ft, knots TAS

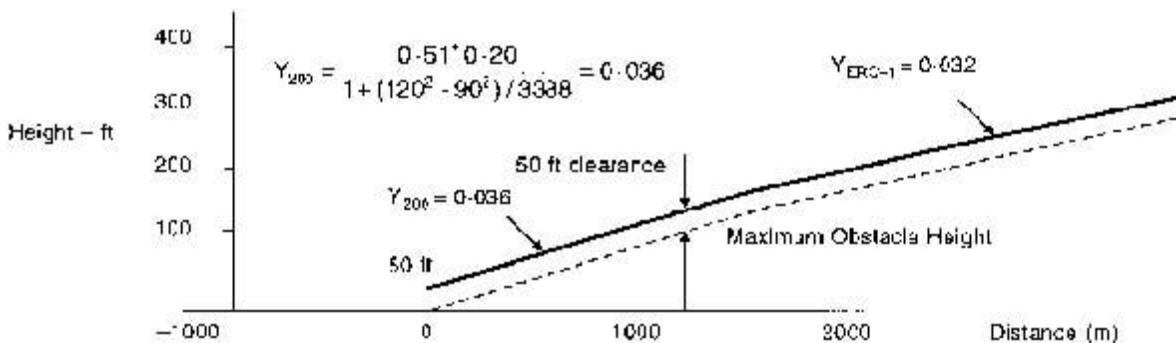

- c. Assumed engine failure height less than 200 ft. Construction of a take-off flight path is only possible if the AFM contains the required flight path data.
- d. Assumed engine failure height more than 300 ft. The construction of a take-off flight path for an assumed engine failure height of 400 ft is illustrated below:

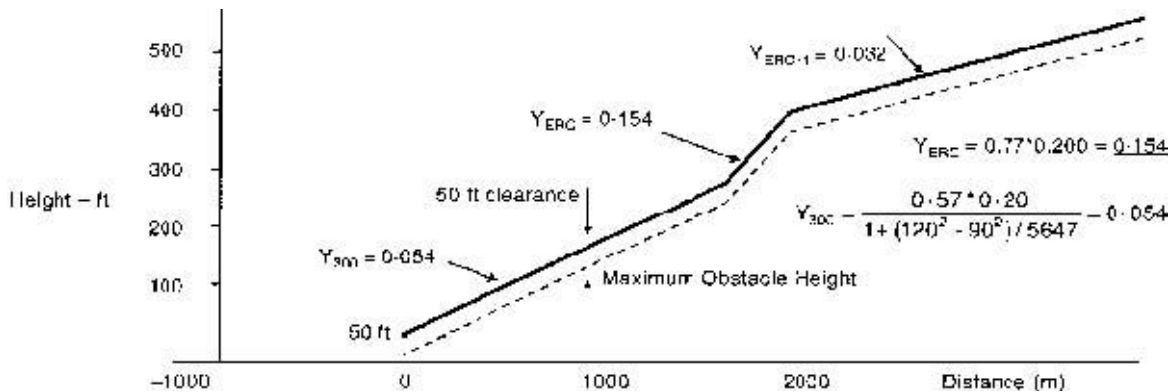

## **IEM OPS 1.540**

### **En-Route**

See JCAR OPS 1.540

1. The altitude at which the rate of climb equals 300 ft per minute is not a restriction on the maximum cruising altitude at which the airplane can fly in practice; it is merely the maximum altitude from which the drift down procedure can be planned to start.
2. Airplanes may be planned to clear en-route obstacles assuming a drift down procedure, having first increased the scheduled en-route one engine inoperative descent data by 0.5% gradient.

## **IEM OPS 1.542**

### **En-route Single engine Airplanes**

See JCAR OPS 1.542

1. In the event of an engine failure, single-engine airplanes have to rely on gliding to a point suitable for a safe forced landing. Such a procedure is clearly incompatible with flight above a cloud layer which extends below the relevant minimum safe altitude.
2. Operators should first increase the scheduled engine-inoperative gliding performance data by 0.5% gradient when verifying the en-route clearance of obstacles and the ability to reach a suitable place for a forced landing.
3. The altitude at which the rate of climb equals 300 ft per minute is not a restriction on the maximum cruising altitude at which the airplane can fly in practice; it is merely the maximum altitude from which the engine-inoperative procedure can be planned to start.

## **AMC OPS 1.542(a)**

### **En-Route Single engine airplanes**

See JCAR OPS 1.542(a)

JCAR OPS 1.542(a) requires an operator to ensure that in the event of an engine failure, the airplane should be capable of reaching a point from which a successful forced landing can be made. Unless otherwise specified by CARC, this point should be 1000ft above the intended landing area.

**AMC OPS 1.545 & 1.550**

**Landing Destination and Alternate Aerodromes Landing - Dry runway**

See JCAR OPS 1.545 & 1.550

In showing compliance with JCAR OPS 1.545 & JCAR OPS 1.550, the operator should use either pressure altitude or geometric altitude for his operation and this should be reflected in the Operations Manual.

**AMC OPS 1.550(b) (3)**

**Landing Distance Correction Factors**

See JCAR OPS 1.550(b) (3)

Unless otherwise specified in the Airplane Flight Manual or other performance or operating manuals from the manufacturers, the variable affecting the landing performance and the associated factor that should be applied to the Airplane Flight Manual data is shown in the table below. It should be applied in addition to the operational factors as prescribed in JCAR OPS 1.550(a).

<b>Surface Type</b>	<b>Factor</b>
Grass (on firm soil up to 20 cm long)	1.15

NOTE. The soil is firm when there are wheel impressions but no rutting

**AMC OPS 1.550(b) (4)**

**Runway Slope**

See JCAR OPS 1.550(b) (4)

Unless otherwise specified in the Airplane Flight Manual, or other performance or operating manuals from the manufacturer, the landing distances required should be increased by 5% for each 1% of down slope except that correction factors for runways with slopes in excess of 2% need the acceptance of CARC.

**IEM OPS 1.550(c)**

**Landing – Dry Runway**

See JCAR OPS 1.550(c)

1. JCAR OPS 1.550(c) establishes two considerations in determining the maximum permissible landing mass at the destination and alternate aerodromes.

2. Firstly, the airplane mass will be such that on arrival the airplane can be landed within 70% of the landing distance available on the most favorable (normally the longest) runway in still air. Regardless of the wind conditions, the maximum landing mass for an aerodrome/airplane configuration at a particular aerodrome cannot be exceeded.
3. Secondly, consideration should be given to anticipated conditions and circumstances. The expected wind, or ATC and noise abatement procedures may indicate the use of a different runway. These factors may result in a lower landing mass than that permitted under paragraph 2 above, in which case, to show compliance with JCAR OPS 1.550(a), dispatch should be based on this lesser mass.
4. The expected wind referred to in paragraph 3 is the wind expected to exist at the time of arrival.

### **IEM OPS 1.555(a)**

#### **Landing on Wet Grass Runways**

See JCAR OPS 1.555(a)

1. When landing on very short grass which is wet, and with a firm subsoil, the surface may be slippery, in which case the distances may increase by as much as 60% (1.60 factor).
2. As it may not be possible for a pilot to determine accurately the degree of wetness of the grass, particularly when airborne, in cases of doubt, the use of the wet factor (1.15) is recommended.



IEM OPS 1.555 (a) (continued)

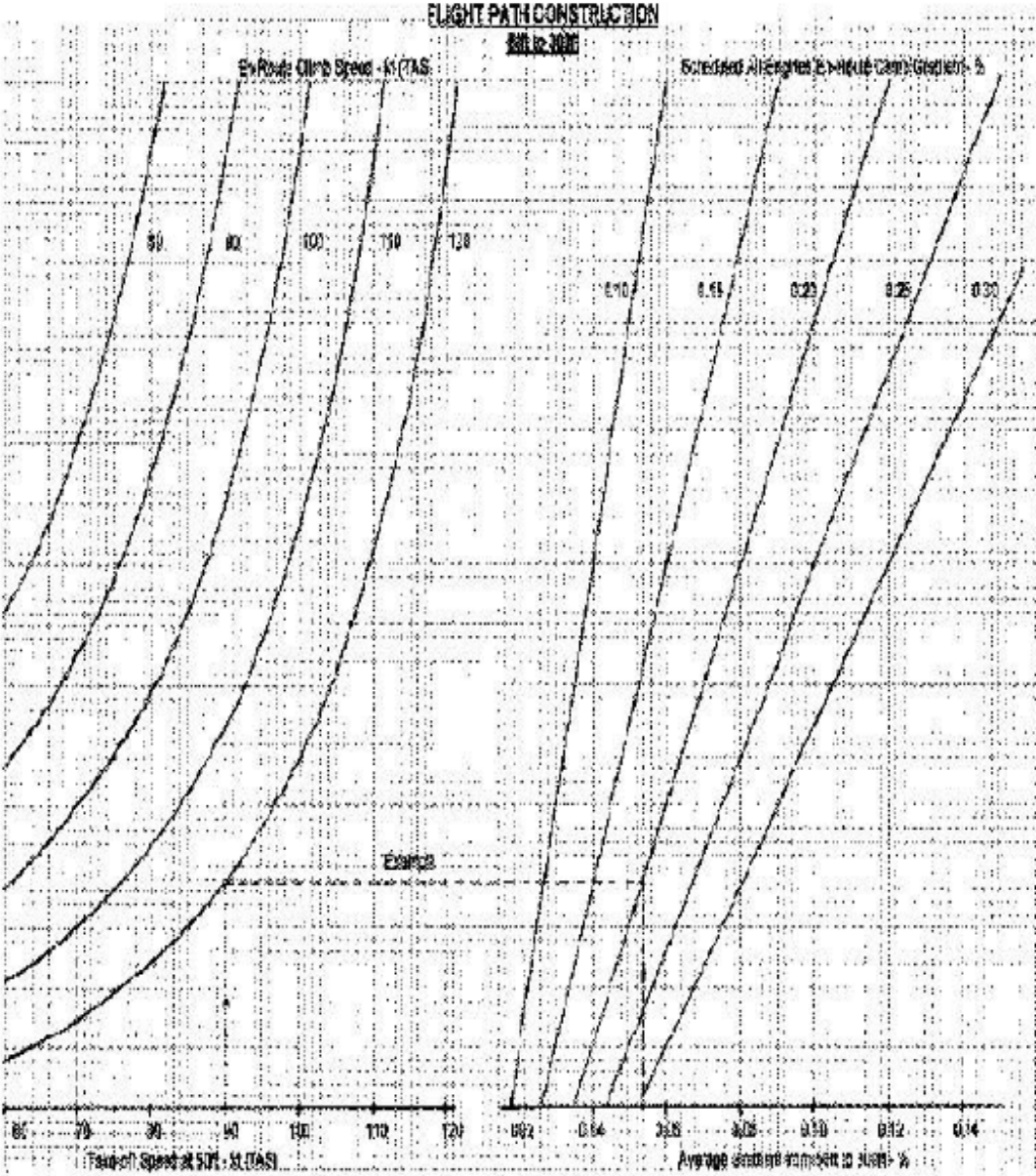

IEM OPS 1.555 (a) (continued)

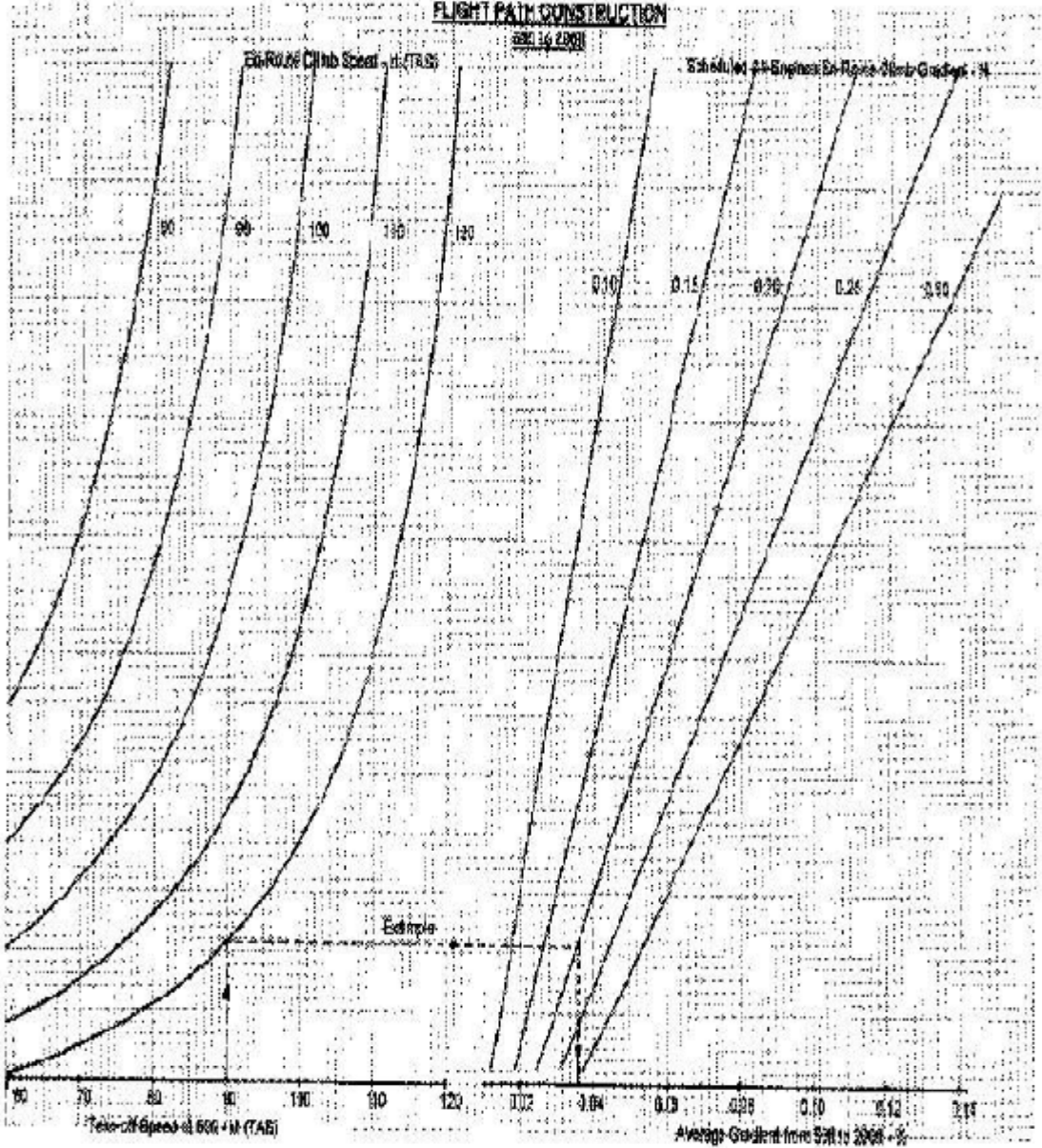

## **AMC/IEM I Performance Class C**

### **IEM OPS 1.565(d) (3)**

#### **Take-off**

See JCAR OPS 1.565(d) (3)

Operation on runways contaminated with water, slush, snow or ice implies uncertainties with regard to runway friction and contaminant drag and therefore to the achievable performance and control of the airplane during take-off, since the actual conditions may not completely match the assumptions on which the performance information is based. An adequate overall level of safety can, therefore, only be maintained if such operations are limited to rare occasions. In case of a contaminated runway the first option for the commander is to wait until the runway is cleared. If this is impracticable, he may consider a take-off, provided that he has applied the applicable performance adjustments, and any further safety measures he considers justified under the prevailing conditions.

### **IEM OPS 1.565(d) (6)**

#### **Loss of runway length due to alignment**

See JCAR OPS 1.565(d) (6)

#### 1. Introduction

- 1.1. The length of the runway which is declared for the calculation of TODA, ASDA and TORA, does not account for line-up of the airplane in the direction of take-off on the runway in use. This alignment distance depends on the airplane geometry and access possibility to the runway in use. Accountability is usually required for a 90° taxiway entry to the runway and 180° turnaround on the runway. There are two distances to be considered:
  - a. The minimum distance of the main wheels from the start of the runway for determining TODA and TORA, “L”; and
  - b. The minimum distance of the most forward wheel(s) from the start of the runway for determining ASDA, “N”.

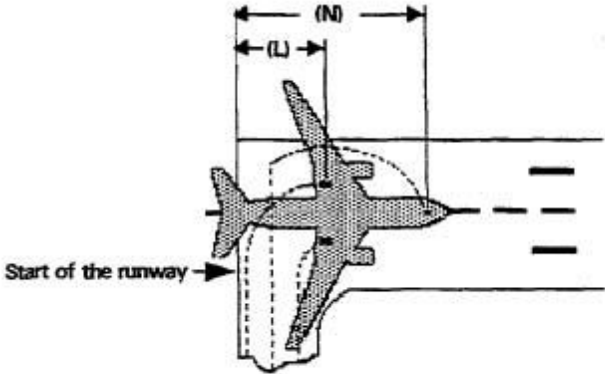

Where the airplane manufacturer does not provide the appropriate data, the calculation method given in paragraph 2 may be use to determine the alignment distance.

2. Alignment Distance Calculation

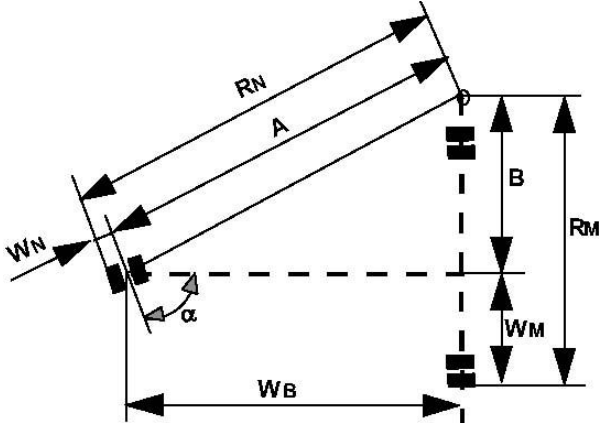

The distances mentioned in (a) and (b) of paragraph 1 above are:

	90° ENTRY	180° TURNAROUND
L =	$R_M + X$	$R_N + Y$
N =	$R_M + X + W_B$	$R_N + Y + W_B$

where:

$$R_N = A + W_N = \frac{W_B}{\cos(90^\circ - \alpha)}$$

and

$$R_M = B + W_M = W_B \tan(90^\circ - \alpha) + W_M$$

X = Safety distance of outer main wheel during turn to the edge of the runway

Y = Safety distance of outer nose wheel during turn to the edge of the runway

NOTE. Minimum edge safety distances for X and Y are specified in FAA AC 150/5300-13 and ICAO Annex14 paragraph 3.8.3

RN = Radius of turn of outer nose wheel

RM = Radius of turn of outer main wheel

WN = Distance from airplane centre-line to outer nose wheel

WM = Distance from airplane centre-line to outer main wheel

WM = Wheel base

a = Steering angle

### **AMC OPS 1.565(d) (4)**

#### **Runway Slope**

See JCAR OPS 1.565(d) (4)

Unless otherwise specified in the Airplane Flight Manual or other performance or operating manuals from the manufacturers, the take-off distance should be increased by 5% for each 1% of upslope except that correction factors for runways with slopes in excess of 2% need the acceptance of CARC.

### **AMC OPS 1.570(d)**

#### **Take-off Flight Path**

See JCAR OPS 1.570(d)

1. The Airplane Flight Manual generally provides a climb gradient decrement for a 15° bank turn. Unless otherwise specified in the Airplane Flight Manual or other performance or operating manuals from the manufacturer, acceptable adjustments to assure adequate stall margins and gradient corrections are provided by the following:

<b>Bank</b>	<b>Speed</b>	<b>Gradient Correction</b>
15°	V <sub>2</sub>	1 x Airplane Flight Manual 15° Gradient Loss
20°	V <sub>2</sub> + 5 kt	2 x Airplane Flight Manual 15° Gradient Loss
25°	V <sub>2</sub> + 10 kt	3 x Airplane Flight Manual 15° Gradient Loss

2. For bank angles of less than 15°, a proportionate amount may be applied, unless the manufacturer or Airplane Flight Manual has provided other data.

## **AMC OPS 1.570(e) (1) & (f) (1)** **Required navigational accuracy**

See JCAR OPS 1.570(e) (1) & (f) (1)

1. Flight-deck systems. The obstacle accountability semi-widths of 300 m (See JCAR OPS 1.570(e)(1)) and 600 m (See JCAR OPS 1.570(f)(1)) may be used if the navigation system under one-engine-inoperative conditions provides a two standard deviation (2 s) accuracy of 150 m and 300 m respectively.
2. Visual Course Guidance
  - 2.1 The obstacle accountability semi-widths of 300 m (See JCAR OPS 1.570(e)(1)) and 600 m (See JCAR OPS 1.570(f)(1)) may be used where navigational accuracy is ensured at all relevant points on the flight path by use of external references. These references may be considered visible from the flight deck if they are situated more than 45° either side of the intended track and with a depression of not greater than 20° from the horizontal.
  - 2.2 For visual course guidance navigation, an operator should ensure that the weather conditions prevailing at the time of operation, including ceiling and visibility, are such that the obstacle and/or ground reference points can be seen and identified. The Operations Manual should specify, for the aerodrome(s) concerned, the minimum weather conditions which enable the flight crew to continuously determine and maintain the correct flight path with respect to ground reference points, so as to provide a safe clearance with respect to obstructions and terrain as follows:
    - a. The procedure should be well defined with respect to ground reference points so that the track to be flown can be analyzed for obstacle clearance requirements;
    - b. The procedure should be within the capabilities of the airplane with respect to forward speed, bank angle and wind effects;
    - c. A written and/or pictorial description of the procedure should be provided for crew use;
    - d. The limiting environmental conditions (such as wind, the lowest cloud base, ceiling, visibility, day/night, ambient lighting, obstruction lighting) should be specified.

## **AMC OPS 1.580**

### **En-Route – One Engine Inoperative**

See JCAR OPS 1.580

The high terrain or obstacle analysis required for showing compliance with JCAR OPS 1.580 can be carried out by making a detailed analysis of the route using contour maps of the high terrain, and plotting the highest points within the prescribed corridor width along the route. The next step is to determine whether it is possible to maintain level flight with one engine inoperative 1000 ft above the highest point of the crossing. If this is not possible, or if the associated weight penalties are unacceptable, a drift-down procedure must be evaluated, based on engine failure at the most critical point, and must show obstacle clearance during the drift-down by at least 2000 ft. The minimum cruise altitude is determined from the drift down path, taking into account allowances for decision making, and the reduction in the scheduled rate of climb (See Figure 1).

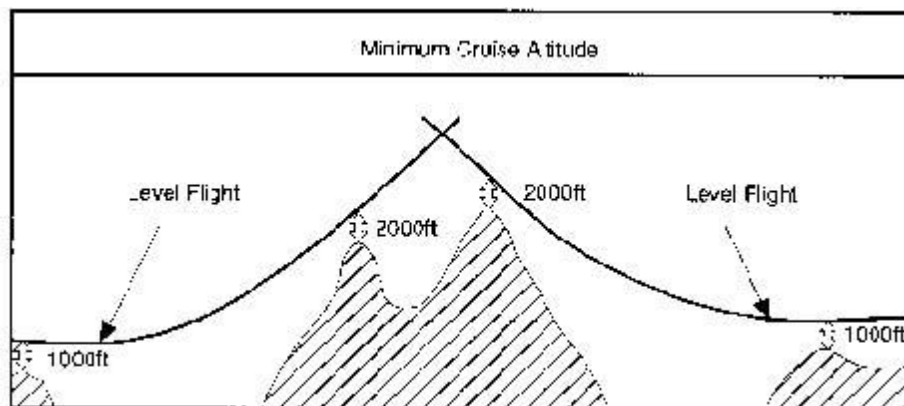

Figure 1

## **AMC OPS 1.590 & 1.595**

### **Landing – Destination and Alternate Aerodromes**

### **Landing – Dry Runways**

See JCAR OPS 1.590 & 1.595

In showing compliance with JCAR OPS 1.590 and JCAR OPS 1.595, the operator should use either pressure altitude or geometric altitude for his operation and this should be reflected in the Operations Manual.

**AMC OPS 1.595(b) (3)**  
**Landing Distance Correction Factors**

See JCAR OPS 1.595(b) (3)

Unless otherwise specified in the Airplane Flight Manual or other performance or operating manuals from the manufacturers, the variables affecting the landing performance and the associated factors to be applied to the Airplane Flight Manual data are shown in the table below. It should be applied in addition to the factor specified in JCAR OPS 1.595(a)

<b>SURFACE TYPE</b>	<b>FACTOR</b>
Grass (on firm soil up to 13 cm long)	1.20

NOTE. The soil is firm when there are wheel impressions but no rutting.

**AMC OPS 1.595(b) (4)**  
**Runway Slope**

See JCAR OPS 1.595(b) (4)

Unless otherwise specified in the Airplane Flight Manual or other performance or operating manuals from the manufacturer, the landing distances required should be increased by 5% for each 1% of down slope.

**IEM OPS 1.595(c)**  
**Landing Runway**

See JCAR OPS 1.595(c)

1. JCAR OPS 1.595(c) establishes two considerations in determining the maximum permissible landing mass at the destination and alternate aerodromes.
2. Firstly, the airplane mass will be such that on arrival the airplane can be landed within 70% of the landing distance available on the most favorable (normally the longest) runway in still air. Regardless of the wind conditions, the maximum landing mass for an aerodrome/airplane configuration at a particular aerodrome cannot be exceeded.



3. Secondly, consideration should be given to anticipated conditions and circumstances. The expected wind, or ATC and noise abatement procedures may indicate the use of a different runway. These factors may result in a lower landing mass than that permitted under paragraph 2 above, in which case, to show compliance with JCAR OPS 1.595(a), dispatch should be based on this lesser mass.
4. The expected wind referred to in paragraph 3 is the wind expected to exist at the time of arrival.

## AC/AMC/IEM J Mass & Balance

### **IEM OPS 1.605(e)**

#### **Fuel density**

See JCAR OPS 1.605(e)

1. If the actual fuel density is not known, the operator may use the standard fuel density values specified in the Operations Manual for determining the mass of the fuel load. Such standard values should be based on current fuel density measurements for the airports or areas concerned. Typical fuel density values are:
  - a. Gasoline (piston engine fuel) – 0.71
  - b. Jet fuel JP 1 – 0.79
  - c. Jet fuel JP 4 – 0.76
  - d. Oil – 0.88

### **AC OPS 1.605**

#### **Mass values**

See JCAR OPS 1.605

In accordance with ICAO Annex 5 and the International System of Units (SI), the actual and limiting masses of airplanes, the payload and its constituent elements, the fuel load etc, are expressed in JCAR OPS 1 in units of mass (kg). However, in most approved Flight Manuals and other operational documentation, these quantities are published as weights in accordance with the common language. In the SI system, a weight is a force rather than a mass. Since the use of the term ‘weight’ does not cause any problem in the day-to-day handling of airplanes, its continued use in operational applications and publications is acceptable.

## **AMC to Appendix 1 to JCAR OPS 1.605**

### **Accuracy of weighing equipment**

See Appendix 1 to JCAR OPS 1.605, paragraph (a) (4) (iii)

1. The mass of the airplane as used in establishing the dry operating mass and the centre of gravity must be established accurately. Since a certain model of weighing equipment is used for initial and periodic weighing of airplanes of widely different mass classes, one single accuracy criterion for weighing equipment cannot be given. However, the weighing accuracy is considered satisfactory if the following accuracy criteria are met by the individual scales/cells of the weighing equipment used:
  - a. For a scale/cell load below 2 000 kg – an accuracy of  $\pm 1\%$ ;
  - b. For a scale/cell load from 2 000 kg to 20 000 kg – an accuracy of  $\pm 20$  kg; and
  - c. For a scale/cell load above 20 000 kg – an accuracy of  $\pm 0.1\%$ .

## **IEM to Appendix 1 to JCAR OPS 1.605**

### **Centre of gravity limits**

See Appendix 1 to JCAR OPS 1.605, sub-paragraph (d)

1. In the Certificate Limitations section of the Airplane Flight Manual, forward and aft centre of gravity (CG) limits are specified. These limits ensure that the certification stability and control criteria are met throughout the whole flight and allow the proper trim setting for take-off. An operator should ensure that these limits are observed by defining operational procedures or a CG envelope which compensates for deviations and errors as listed below:
  - 1.1 Deviations of actual CG at empty or operating mass from published values due, for example, to weighing errors, unaccounted modifications and/or equipment variations.
  - 1.2 Deviations in fuel distribution in tanks from the applicable schedule.
  - 1.3 Deviations in the distribution of baggage and cargo in the various compartments as compared with the assumed load distribution as well as inaccuracies in the actual mass of baggage and cargo.
  - 1.4 Deviations in actual passenger seating from the seating distribution assumed when preparing the mass and balance documentation. (See Note)

- 1.5 Deviations of the actual CG of cargo and passenger load within individual cargo compartments or cabin sections from the normally assumed mid position.
- 1.6 Deviations of the CG caused by gear and flap positions and by application of the prescribed fuel usage procedure (unless already covered by the certified limits).
- 1.7 Deviations caused by in-flight movement of cabin crew, pantry equipment and passengers.

Note. Large CG errors may occur when ‘free seating’ (freedom of passengers to select any seat when entering the airplane) is permitted. Although in most cases reasonably even longitudinal passenger seating can be expected, there is a risk of an extreme forward or aft seat selection causing very large and unacceptable CG errors (assuming that the balance calculation is done on the basis of an assumed even distribution). The largest errors may occur at a load factor of approximately 50% if all passengers are seated in either the forward or aft half of the cabin. Statistical analysis indicates that the risk of such extreme seating adversely affecting the CG is greatest on small airplanes.

### **AMC OPS 1.620(a)**

#### **Passenger mass established by use of a verbal statement**

See JCAR OPS 1.620(a)

1. When asking each passenger on airplanes with less than 10 passenger seats for his/her mass (weight), specific constants should be added to account for hand baggage and clothing. These constants should be determined by the operator on the basis of studies relevant to his particular routes, etc. and should not be less than:
  - a. For clothing - 4 kg; and
  - b. For hand baggage - 6 kg.
2. Personnel boarding passengers on this basis should assess the passenger’s stated mass and the mass of passengers’ clothing and hand baggage to check that they are reasonable. Such personnel should have received instruction on assessing these mass values. Where necessary, the stated mass and the specific constants should be increased so as to avoid gross inaccuracies.

## **IEM OPS 1.620(d) (2)**

### **Holiday Charter**

See JCAR OPS 1.620(d) (2)

A “charter flight solely intended as an element of a holiday travel package” is a flight where the entire passenger capacity is hired by one or more Charterer(s) for the carriage of passengers who are travelling, all or in part by air, on a round- or circle-trip basis for holiday purposes. Categories of passengers such as company personnel, tour operators’ staff, representatives of the press, Authority officials etc. can be included within the 5% alleviation without negating the use of holiday charter mass values.

## **IEM OPS 1.620(g)**

### **Statistical evaluation of passenger and baggage mass data**

See JCAR OPS 1.620(g)

1. Sample size (See also Appendix 1 to JCAR OPS 1.620(g)).
  - 1.1 For calculating the required sample size it is necessary to make an estimate of the standard deviation on the basis of standard deviations calculated for similar populations or for preliminary surveys. The precision of a sample estimate is calculated for 95% reliability or ‘significance’, i.e. there is a 95% probability that the true value falls within the specified confidence interval around the estimated value. This standard deviation value is also used for calculating the standard passenger mass.
  - 1.2 As a consequence, for the parameters of mass distribution, i.e. mean and standard deviation, three cases have to be distinguished:
    - a.  $\mu$ ,  $\sigma$  the true values of the average passenger mass and standard deviation, which are unknown and which are to be estimated by weighing passenger samples.
    - b.  $\mu$ ,  $\sigma$ ’ the ‘a priori’ estimates of the average passenger mass and the standard deviation, i.e. values resulting from an earlier survey, which are needed to determine the current sample size.
    - c.  $\bar{x}$ ,  $s$  the estimates for the current true values of  $m$  and  $s$ , calculated from the sample.

The sample size can then be calculated using the following formula:

$$n \geq \frac{(1.96 * \sigma' * 100)^2}{(e_r * \mu')^2}$$

Where:

n = number of passengers to be weighed (Sample size)  
e r = allowed relative confidence range (accuracy) for the estimate of  $\mu$  by  $\bar{x}$   
(See also equation in paragraph 3)

NOTE. The allowed relative confidence range specifies the accuracy to be achieved when estimating the true mean. For example, if it is proposed to estimate the true mean to within  $\pm 1\%$ , then e'r will be 1 in the above formula.

1.69 = value from the Gaussian distribution for 95% significance level of the resulting confidence interval

2. Calculation of average mass and standard deviation. If the sample of passengers weighed is drawn at random, then the arithmetic mean of the sample ( $\bar{x}$ ) is an unbiased estimate of the true average mass ( $\mu$ ) of the population.

2.1 Arithmetic mean of sample

$$\bar{x} = \frac{\sum_{j=1}^n x_j}{n}$$

where:

$x_j$  = mass values of individual passengers (sampling units).

2.2 Standard deviation

$$s = \sqrt{\frac{\sum_{j=1}^n (x_j - \bar{x})^2}{n - 1}}$$

where:

$x_j -$  = deviation of the individual value from the sample mean.

3. Checking the accuracy of the sample mean. The accuracy (confidence range) which can be ascribed to the sample mean as an indicator of the true mean is a function of the standard deviation of the sample which has to be checked after the sample has been evaluated. This is done using the formula:

$$e_r = \frac{1.96 * s * 100}{\sqrt{n} * \bar{x}} (\%)$$

whereby  $e_r$  should not exceed 1% for an all adult average mass and not exceed 2% for an average male and/or female mass. The result of this calculation gives the relative accuracy of the estimate of  $\mu$  at the 95% significance level. This means that with 95% probability, the true average mass  $\mu$  lies within the interval:

$$\bar{x} \pm \frac{1.96 * s}{\sqrt{n}}$$

4. Example of determination of the required sample size and average passenger mass
- 4.1 Introduction. Standard passenger mass values for mass and balance purposes require passenger weighing programs be carried out. The following example shows the various steps required for establishing the sample size and evaluating the sample data. It is provided primarily for those who are not well versed in statistical computations. All mass figures used throughout the example are entirely fictitious.
- 4.2 Determination of required sample size. For calculating the required sample size, estimates of the standard (average) passenger mass and the standard deviation are needed. The 'a priori' estimates from an earlier survey may be used for this purpose. If such estimates are not available, a small representative sample of about 100 passengers has to be weighed so that the required values can be calculated. The latter has been assumed for the example.

Step 1: estimated average passenger mass

Step 2: estimated standard deviation

n	x <sub>j</sub> (kg)
1	79.9
2	68.1
3	77.9
4	74.5
5	54.1
6	$\bar{x}$ 62.2
7	89.3
8	108.7
.	.
85	63.2
86	75.4
<hr/>	
$\sum_{j=1}^{86}$	6 071.6

n	x <sub>j</sub>	(x <sub>j</sub> - $\bar{x}$ )	(x <sub>j</sub> - $\bar{x}$ ) <sup>2</sup>
1	79.9	+9.3	86.49
2	68.1	-2.5	6.25
3	77.9	+7.3	53.29
4	74.5	+3.9	15.21
5	54.1	-16.5	272.25
6	62.2	-8.4	70.56
7	89.3	+18.7	349.69
8	108.7	+38.1	1 451.61
.	.	.	.
85	63.2	-7.4	54.76
86	75.4	-4.8	23.04
<hr/>			
$\sum_{j=1}^{86}$	6 071.6		34 683.40

$$\mu' = \bar{x} = \frac{\sum x_j}{n} = \frac{6071.6}{86} = 70.6 \text{ kg}$$

$$\sigma' = \sqrt{\frac{\sum (x_j - \bar{x})^2}{n-1}}$$

$$\sigma' = \sqrt{\frac{34\,683.40}{86-1}}$$

$$\sigma' = 20.20 \text{ kg}$$

Step 3: required sample size.

The required number of passengers to be weighed should be such that the confidence range, e'r, does not exceed 1% as specified in paragraph 3.

$$n \geq \frac{(1.96 * \sigma' * 100)^2}{(e'_r * \mu')^2}$$

$$n \geq \frac{(1.96 * 20.20 * 100)^2}{(1 * 70.6)^2}$$

$$n \geq 3145$$

The result shows that at least 3 145 passengers have to be weighed to achieve the required accuracy. If e'r is chosen as 2% the result would be n ≥ 786.

Step 4: after having established the required sample size a plan for weighing the passengers is to be worked out, as specified in Appendix 1 to JCAR OPS 1.620(g).



### 4.3 Determination of the passenger average mass

Step 1: Having collected the required number of passenger mass values, the average passenger mass can be calculated. For the purpose of this example it has been assumed that 3 180 passengers were weighed. The sum of the individual masses amounts to 231 186.2 kg.

$$n = 3180$$

$$\sum_{j=1}^{3180} X_j = 231186.2 \text{ kg}$$

$$\bar{x} = \frac{\sum X_j}{n} = \frac{231186.2}{3180} \text{ kg}$$

$$\bar{x} = 72.7 \text{ kg}$$

Step 2: calculation of the standard deviation.

For calculating the standard deviation the method shown in paragraph 4.2 step 2 should be applied.

$$\sum (x_j - \bar{x})^2 = 745\,145.20$$

$$s = \sqrt{\frac{\sum (x_j - \bar{x})^2}{n - 1}}$$

$$s = \sqrt{\frac{745\,145.20}{3180 - 1}}$$

$$s = 15.31 \text{ kg}$$

Step 3: calculation of the accuracy of the sample mean.

$$e_r = \frac{1.96 * s * 100}{\sqrt{n} * \bar{x}} \%$$

$$e_r = \frac{1.96 * 15.31 * 100}{\sqrt{3180} * 72.7} \%$$

$$e_r = 0.73\%$$

Step 4: calculation of the confidence range of the sample mean.

$$\bar{x} \pm \frac{1.96 * s}{\sqrt{n}}$$

$$\bar{x} \pm \frac{1.96 * 15.31}{\sqrt{3180}} \text{ kg}$$

$$72.7 \pm 0.5 \text{ kg}$$

The result of this calculation shows that there is a 95% probability of the actual mean for all passengers lying within the range 72.2 kg to 73.2 kg.

### **IEM OPS 1.620(h) & (i)**

#### **Adjustment of standard masses**

See JCAR OPS 1.620(h) & (i)

1. When standard mass values are used, JCAR OPS 1.620 (h) and 1.620(i) require the operator to identify and adjust the passenger and checked baggage masses in cases where significant numbers of passengers or quantities of baggage are suspected of exceeding the standard values. This requirement implies that the Operations Manual should contain appropriate directives to ensure that:
  - a. Check-in, operations and cabin staff and loading personnel report or take appropriate action when a flight is identified as carrying a significant number of passengers whose masses, including hand baggage, are expected to exceed the standard passenger mass, and/or groups of passengers carrying exceptionally heavy baggage (eg. military personnel or sports teams); and
  - b. On small airplanes, where the risks of overload and/or CG errors are the greatest, commanders pay special attention to the load and its distribution and make proper adjustments.

## **AMC to Appendix 1 to JCAR OPS 1.620(g)**

### **Guidance on passenger weighing surveys**

See Appendix 1 to JCAR OPS 1.620(g), sub-paragraph (c) (4)

1. Operators Seeking approval to use standard passenger masses differing from those prescribed in JCAR OPS 1.620, Tables 1 and 2, on similar routes or networks may pool their weighing surveys provided that:
  - a. CARC has given prior approval for a joint survey;
  - b. The survey procedures and the subsequent statistical analysis meet the criteria of Appendix 1 to JCAR OPS 1.620(g); and
  - c. In addition to the joint weighing survey results, results from individual operators participating in the joint survey should be separately indicated in order to validate the joint survey results.

## **IEM to Appendix 1 to JCAR OPS 1.620(g)**

### **Guidance on passenger weighing surveys**

See Appendix 1 to JCAR OPS 1.620(g)

1. This IEM summarizes several elements of passenger weighing surveys and provides explanatory and interpretative information.
2. Information to CARC. An operator should advise CARC about the intent of the passenger weighing survey, explain the survey plan in general terms and obtain prior approval to proceed (JCAR OPS 1.620(g) refers).
3. Detailed survey plan
  - 3.1 An operator should establish and submit for approval to CARC a detailed weighing survey plan that is fully representative of the operation, i.e. the network or route under consideration and the survey should involve the weighing of an adequate number of passengers (JCAR OPS 1.620(g)).
  - 3.2 A representative survey plan means a weighing plan specified in terms of weighing locations, dates and flight numbers giving a reasonable reflection of the operator's timetable and/or area of operation (See Appendix 1 to JCAR OPS 1.620(g), sub-paragraph (a)(1)).

- 3.3 The minimum number of passengers to be weighed is the highest of the following (See Appendix 1 to JCAR OPS 1.620(g) sub-paragraph (a)):
- a. The number that follows from the general requirement that the sample should be representative of the total operation to which the results will be applied; this will often prove to be the overriding requirement; or
  - b. The number that follows from the statistical requirement specifying the accuracy of the resulting mean values which should be at least 2% for male and female standard masses and 1% for all adult standard masses, where applicable. The required sample size can be estimated on the basis of a pilot sample (at least 100 passengers) or from previous surveys. If analysis of the results of the survey indicates that the requirements on the accuracy of the mean values for male or female standard masses or all adult standard masses, as applicable, are not met, an additional number of representative passengers should be weighed in order to satisfy the statistical requirements.
- 3.4 To avoid unrealistically small samples a minimum sample size of 2 000 passengers (males + females) is also required, except for small airplanes where in view of the burden of the large number of flights to be weighed to cover 2 000 passengers, a lesser number is considered acceptable.
4. Execution of weighing program
- 4.1 At the beginning of the weighing program it is important to note, and to account for, the data requirements of the weighing survey report (See paragraph 7 below).
  - 4.2 As far as is practicable, the weighing program should be conducted in accordance with the specified survey plan.
  - 4.3 Passengers and all their personal belongings should be weighed as close as possible to the boarding point and the mass, as well as the associated passenger category (male/female/child), should be recorded.

5. Analysis of results of weighing survey

5.1 The data of the weighing survey should be analyzed as explained in IEM OPS 1.620(g). To obtain an insight to variations per flight, per route etc. this analysis should be carried out in several stages, i.e. by flight, by route, by area, inbound/outbound, etc. Significant deviations from the weighing survey plan should be explained as well as their possible effect(s) on the results.

6. Results of the weighing survey

6.1 The results of the weighing survey should be summarized. Conclusions and any proposed deviations from published standard mass values should be justified. The results of a passenger weighing survey are average masses for passengers, including hand baggage, which may lead to proposals to adjust the standard mass values given in JCAR OPS 1.620 Tables 1 and 2. As stated in Appendix 1 to JCAR OPS 1.620(g), sub-paragraph (c), these averages, rounded to the nearest whole number may, in principle, be applied as standard mass values for males and females on airplanes with 20 and more passenger seats. Because of variations in actual passenger masses, the total passenger load also varies and statistical analysis indicates that the risk of a significant overload becomes unacceptable for airplanes with less than 20 seats. This is the reason for passenger mass increments on small airplanes.

6.2 The average masses of males and females differ by some 15 kg or more and because of uncertainties in the male/female ratio the variation of the total passenger load are greater if all adult standard masses are used than when using separate male and female standard masses. Statistical analysis indicates that the use of all adult standard mass values should be limited to airplanes with 30 passenger seats or more.

6.3 As indicated in Appendix 1 to JCAR OPS 1.620(g), standard mass values for all adults must be based on the averages for males and females found in the sample, taking into account a reference male/female ratio of 80/20 for all flights except holiday charters where a ratio of 50/50 applies. An operator may, based on the data from his weighing program, or by proving a different male/female ratio, apply for approval of a different ratio on specific routes or flights.

7. Weighing survey report

7.1 The weighing survey report, reflecting the content of paragraphs 1–6 above, should be prepared in a standard format as follows:

## **WEIGHING SURVEY REPORT**

### **1. Introduction**

- Objective and brief description of the weighing survey

### **2. Weighing survey plan**

- Discussion of the selected flight number, airports, dates, etc.
- Determination of the minimum number of passengers to be weighed.
- Survey plan.

### **3 Analysis and discussion of weighing survey results**

- Significant deviations from survey plan (if any).
- Variations in means and standard deviations in the network.
- Discussion of the (summary of) results.

### **4 Summary of results and conclusions**

- Main results and conclusions.
- Proposed deviations from published standard mass values.

Attachment 1. Applicable summer and/or winter timetables or flight programs

Attachment 2. Weighing results per flight (showing individual passenger masses and sex); means and standard deviations per flight, per route, per area and for the total network

## **IEM to Appendix 1 to JCAR OPS 1.625**

### **Mass and balance documentation**

See Appendix 1 to JCAR OPS 1.625

For Performance Class B airplanes, the CG position need not be mentioned on the mass and balance documentation if, for example, the load distribution is in accordance with a pre-calculated balance table or if it can be shown that for the planned operations a correct balance can be ensured, whatever the real load is.

## **AC/AMC/IEM K**

### **Instruments and Equipment**

#### **IEM OPS 1.630**

#### **Instruments and Equipment - Approval and Installation**

See JCAR OPS 1.630

1. For Instruments and Equipment required by JCAR OPS 1 Subpart K, “Approved” means that compliance with the applicable TSO design requirements and performance specifications, or equivalent, in force at the time of the equipment approval application, have been demonstrated. Where a TSO does not exist, the applicable airworthiness standards apply unless otherwise prescribed in JCAR OPS 1.
2. “Installed” means that the installation of Instruments and Equipment has been demonstrated to comply with the applicable airworthiness requirements of JCAR CS 23 / JCAR CS 25, or the relevant code used for Type Certification, and any applicable requirement prescribed in JCAR OPS 1.
3. Instruments and Equipment approved in accordance with design requirements and performance specifications other than TSOs, before the applicability dates prescribed in JCAR OPS 1.001(b), are acceptable for use or installation on airplanes operated for the purpose of commercial air transportation provided that any relevant JCAR OPS 1 requirement is complied with.
4. When a new version of a TSO (or of a specification other than a TSO) is issued, Instruments and Equipment approved in accordance with earlier requirements may be used or installed on airplanes operated for the purpose of commercial air transportation provided that such Instruments and Equipment are operational, unless removal from service or withdrawal is required by means of an amendment to JCAR OPS 1.

**AMC OPS 1.650/1.652**

**Flight and Navigational Instruments and Associated Equipment**

See JCAR OPS 1.650/1.652

1. Individual requirements of these paragraphs may be met by combinations of instruments or by integrated flight systems or by a combination of parameters on electronic displays provided that the information so available to each required pilot is not less than that provided by the instruments and associated equipment as specified in this Subpart.
2. The equipment requirements of these paragraphs may be met by alternative means of compliance when equivalent safety of the installation has been shown during type certification approval of the airplane for the intended kind of operation.

**IEM OPS 1.650/1.652**

**Flight and Navigational Instruments and Associated Equipment**

See JCAR OPS 1.650/1.652

Serial	Instrument	Flights Under VFR			Flights Under IFR Or At Night		
		Single Pilot	Two Pilots Required	Max T/O Mass Auth>5700 kg or Max Pass>9 Pax	Single Pilot	Two Pilots Required	Max T/O Mass Auth>5700 kg Or Max Pass>9 Pax
(a)		(b)	(c)	(d)	(e)	(f)	(g)
1	Magnetic Compass	1	1	1	1	1	1
2	Accurate Time Piece	1	1	1	1	1	1
3	OAT Indicator	1	1	1	1	1	1
4	Sensitive Pressure Altimeter	1	2	2	2 Note (5)	2 Note (5)	2 Note (5)
5	Air Speed Indicator	1	2	2	1	2	2
6	Heated Pitot system			2	1	2	2
7	Pitot heat failure Indicator						2
8	Vertical Speed Indicator	1	2	2	1	2	2
9	Turn and slip Indicator OR Turn Co-coordinator	1 Note (1)	2 Notes (1) & (2)	2 Notes (1) & (2)	1 Note (4)	2 Note (4)	2 Note (4)
10	Attitude Indicator	1 Note (1)	2 Notes (1) & (2)	2 Notes (1) & (2)	1	2	2
11	Gyroscopic Direction Indicator	1	2	2	1	2	2
12	Standby Attitude Indicator						1
13	Mach Number Indicator	See Note (3) for all airplanes					

**NOTES:**

- (1) For local flights (A to A, 50 Nm radius, not more than 60 minutes duration) the instruments at Serials 9 (b) 10 (b) and 11 (b) may be replaced by EITHER a turn and slip indicator, OR a turn coordinator, OR both an attitude indicator and a slip indicator.



- (2) The substitute instruments permitted by Note (1) shall be provided at each pilot's station.
- (3) Serial 13 - A Mach number indicator is required for each pilot whenever compressibility limitations are not otherwise indicated by airspeed indicators.
- (4) For IFR or at night, a Turn and Slip indicator, or a slip indicator and a third (standby) attitude indicator certificated according to JCAR CS 25.1303(b) (4) or equivalent, is required.
- (5) Neither Three pointers, nor drum pointer altimeters satisfy the requirement.

### **AMC OPS 1.650(i) & 1.652(i)**

#### **Flight and Navigational Instruments and Associated Equipment**

See JCAR OPS 1.650(i) & 1.652(i)

A means to indicate outside air temperature indicator may be an air temperature indicator which provides indications that are convertible to outside air temperature.

### **IEM OPS 1.650(p)/1.652(s)**

#### **Headset, boom microphone and associated equipment**

See JCAR OPS 1.650(p)/1.652(s)

A headset, as required by JCAR OPS 1.650(p) and JCAR OPS 1.652(s), consists of a communication device which includes an earphone(s) to receive and a microphone to transmit audio signals to the airplane's communication system. To comply with the minimum performance requirements, the earphone(s) and microphone should match with the communication system's characteristics and the flight deck environment. The headset should be adequately adjustable to fit the pilot's head. Headset boom microphones should be of the noise cancelling type.

### **AMC OPS 1.652(d) & (k) (2)**

#### **Flight and Navigational Instruments and Associated Equipment**

See JCAR OPS 1.652(d) & (k) (2)

A combined pitot heater warning indicator is acceptable provided that a means exists to identify the failed heater in systems with two or more sensors.

## **IEM OPS 1.668**

### **Airborne Collision Avoidance System**

See JCAR OPS 1.668

The minimum performance level for ACAS II is contained in ICAO Annex 10, Volume IV Chapter 4.

## **AC OPS 1.680(a) (2)**

### **Quarterly Radiation Sampling**

See JCAR OPS 1.680(a) (2)

1. Compliance with JCAR OPS 1.680(a) (2) may be shown by conducting quarterly radiation sampling during airplane operation using the following criteria:
  - a. The sampling should be carried out in conjunction with a Radiological Agency or similar organization acceptable to CARC;
  - b. Sixteen route sectors which include flight above 49 000 ft should be sampled every quarter (three months). Where less than sixteen route sectors which include flight above 49 000 ft are achieved each quarter, then all sectors above 49 000 ft should be sampled.
  - c. The cosmic radiation recorded should include both the neutron and non-neutron components of the radiation field.
2. The results of the sampling, including a cumulative summary quarter on quarter, should be reported to CARC under arrangements acceptable to CARC.

## **AMC OPS 1.690(b) (6)**

### **Crew member interphone system**

See JCAR OPS 1.690(b) (6)

1. The means of determining whether or not an interphone call is a normal or an emergency call may be one or a combination of the following:
  - i. Lights of different colors;
  - ii. Codes defined by the operator (e.g. different number of rings for normal and emergency calls);
  - iii. Any other indicating signal acceptable to CARC.

## **IEM OPS 1.690(b) (7)**

### **Crew member interphone system**

See JCAR OPS 1.690(b) (7)

At least one interphone system station for use by ground personnel should be, where practicable, so located that the personnel using the system may avoid detection from within the airplane.

## **AC OPS 1.700**

### **Cockpit Voice Recorders**

See JCAR OPS 1.700

The operational performance requirements for Cockpit Voice Recorders should be those laid down in EUROCAE Document ED56A (Minimum Operational Performance Requirements for Cockpit Voice Recorder Systems) December 1993.

## **AC OPS 1.705/1.710**

### **Cockpit Voice Recorders**

See JCAR OPS 1.705/1.710

Account should be taken of the operational performance requirements for Cockpit Voice Recorders as laid down in EUROCAE Documents ED56 or ED56A (Minimum Operational Performance Requirements For Cockpit Voice Recorder Systems) dated February 1988 and December 1993 respectively.

## **AC OPS 1.700, 1.705 and 1.710**

### **Cockpit Voice Recorders**

See JCAR OPS 1.705 and 1.710

Summary table of applicable requirements

<b>All Airplanes (See JCAR OPS 1.710 CVR-3)</b>		<b>All Airplanes (See JCAR OPS 1.700 CVR-1)</b>
No Requirement	All Multiengine Turbine Powered Airplanes with a MAPSC of more than 9 (applicability: 1 April 2000) (See JCAR OPS 1.705 CVR-2)	All Multiengine Turbine Powered Airplanes with a MAPSC of more than 9 (See JCAR OPS 1.705 CVR-1)

NOTE 1:

MCTOM = Maximum Certificated Take of Mass

MAPSC = Maximum Approved Passenger Seating Configuration

## **AC OPS 1.715**

### **Flight Data Recorders**

See JCAR OPS 1.715

1. The operational performance requirements for Flight Data Recorders should be those laid down in EUROCAE Document ED55 (Minimum Operational Performance Specification for Flight Data Recorder Systems) dated May 1990.
2. The parameters to be recorded should meet, as far as practicable, the performance specifications (designated ranges, sampling intervals, accuracy limits and minimum resolution in read-out) defined in the relevant tables of EUROCAE Minimum Operational Performance Specification for Flight Data Recorder Systems, Document ED 55 dated May 1990. The remarks columns of those tables are acceptable means of compliance to the parameter specifications.
3. For airplanes with novel or unique design or operational characteristics, the additional parameters should be those required in accordance with JCAR CS 25.1459(e) during type or supplemental type certification or validation.
4. If recording capacity is available, as many of the additional parameters specified in table A1.5 of Document ED 55 dated May 1990 as possible should be recorded.

## **AC OPS 1.715(g)**

### **Extensive Modifications of Airplane Systems**

See JCAR OPS 1.715(g)

The alleviation policy included in JCAR OPS 1.715(g) affects a small number of airplanes first issued with a C of A on or after 1 April 1998 that were either constructed prior to this date or to a specification in force just prior to this date. These airplanes may not comply fully with JCAR OPS 1.715, but are able to comply with JCAR OPS 1.720. In granting such alleviation, CARC should confirm that the above conditions have been met and that compliance with JCAR OPS 1.715 would imply significant modifications to the airplane with a severe re-certification effort.

## **AC OPS 1.720 /1.725**

### **Flight Data Recorders**

See JCAR OPS 1.720 /1.725 & Appendix 1 to AC OPS 1.720 /1.725

1. The parameters to be recorded should meet the performance specifications (designated ranges, recording intervals and accuracy limits) defined in Table 1 of Appendix 1 to AC OPS 1.720/1.725. Remarks in Table 1 of Appendix 1 to AC OPS 1.720/1.725 is acceptable means of compliance to the parameters requirements.
2. Flight data recorder systems, for which the recorded parameters do not comply with the performance specifications of Table 1 of Appendix 1 to AC OPS 1.720/1.725 (i.e. range, sampling intervals, accuracy limits and recommended resolution readout) may be acceptable to CARC.
3. For all airplanes, so far as practicable, when further recording capacity is available, the recording of the following additional parameters should be considered:
  - a. Remaining parameters in Table B of Appendix 1 to JCAR OPS 1.720 or JCAR OPS 1.725 as applicable;
  - b. Any dedicated parameter relating to novel or unique design or operational characteristics of the airplane;
  - c. Operational information from electronic display systems, such as EFIS, ECAM or EICAS, with the following order of priority:
    - i) Parameters selected by the flight crew relating to the desired flight path, e.g. barometric pressure setting, selected altitude, selected airspeed, decision height, and auto flight system engagement and mode indications if not recorded from another source;
    - ii) Display system selection/status, e.g. SECTOR, PLAN, ROSE, NAV, WXR, COMPOSITE, COPY, etc;
    - iii) Warning and alerts;
    - iv) The identity of displayed pages from emergency procedures and checklists.

- d. Retardation information including brake application for use in the investigation of landing overruns or rejected take offs; and
  - e. Additional engine parameters (EPR, N1, EGT, fuel flow, etc.)
4. For the purpose of JCAR OPS 1.720(d), 1.720(e) and 1.725(c)(2), the alleviation should be acceptable only when adding the recording of missing parameters to the existing flight data recorder system would require a major upgrade of the system itself. Account should be taken of the following:
- a. The extent of the modification required
  - b. The down-time period; and
  - c. Equipment software development.
5. For the purpose of JCAR OPS 1.720(d), 1.720(e), 1.725(c) (2) and 1.725(c) (3) "capacity available" refers to the space on both Flight Data Acquisition Unit and the flight data recorder not allocated for recording the required parameters, or the parameters recorded for the purpose of JCAR OPS 1.037 (Accident prevention and flight safety program) as acceptable to CARC.
6. For the purpose of JCAR OPS 1.720(d) (1), 1.720(e) (1), 1.725(c) (2)(i) and 1.725(c)(3) a sensor is considered "readily available" when it is already available or can be easily incorporated.

## AC OPS 1.715, 1.720 and 1.725 Flight Data Recorders

See JCAR OPS 1.715, 1.720 and 1.725

Summary table of applicable requirements and parameters recorded

MCTOM	See Appendix 1 to JAR-OPS 1.725	See Appendix 1 to JAR-OPS 1.720	See Appendix 1 to JAR-OPS 1.715
	<p><b>TURBINE POWERED AEROPLANES</b></p> <ul style="list-style-type: none"> <li>Table A (1.725) param. 1 - 5; and</li> <li>For aeroplanes of a type first type certificated after 30.09.69 Table B (1.725) param. 6 - 15b; and</li> <li>If sufficient capacity is available on FDR system remaining Table B (1.725) parameters</li> </ul>	<p><b>TURBINE POWERED AEROPLANES</b></p> <ul style="list-style-type: none"> <li>Table A (1.725) param. 1 - 5; and</li> <li>For aeroplanes of a type first type certificated after 30.09.69 Table B (1.725) param. 6 - 15b; and</li> <li>If sufficient capacity is available on FDR system remaining Table B (1.725) parameters</li> </ul>	<p><b>ALL AEROPLANES</b></p> <ul style="list-style-type: none"> <li>Table A1 (1.715) param. 1 - 17; and</li> <li>Table B (1.715) param. 18 - 32; and</li> <li>Table C (EFIS) param. 33 - 42; and</li> <li>Param. relating to novel or unique design features</li> </ul>
27 000 kg	<p><b>TURBINE POWERED AEROPLANES</b></p> <p>Table A (1.725) param. 1 - 5</p>	<p><b>TURBINE POWERED AEROPLANES</b></p> <p>Table A (1.725) param. 1 - 5; and</p> <ul style="list-style-type: none"> <li>If sufficient capacity is available on FDR system Table B (1.725) parameters 6 - 15b</li> </ul>	<p><b>ALL AEROPLANES</b></p> <ul style="list-style-type: none"> <li>Table A1 (1.715) param. 1 - 17; and</li> <li>Table C (EFIS) param. 33 - 42; and</li> <li>Param. relating to novel or unique design features</li> </ul>
5 700 kg	<p>No Requirement</p>	<p>No Requirement</p>	<p><b>MULTI-ENGINE TURBINE POWERED AEROPLANES</b></p> <p>MASPC &gt; 9</p> <ul style="list-style-type: none"> <li>Table A2 (1.715) param. 1 - 17; and</li> <li>Table C (EFIS) param. 33 - 42; and</li> <li>Param. relating to novel or unique design features</li> </ul>
	01.01.87	01.01.89	01.04.98

## **AC OPS 1.727**

### **Combination recorders**

See JCAR OPS 1.727

When two combination recorders are installed, one should be located near the cockpit, in order to minimize the risk of a data loss due to the failure of the wiring that gathers data to the recorder. The other should be located at the rear of the airplane in order to minimize the risk of a data loss due to recorder damage in the case of a crash.

## **AC OPS 1.730(a) (3)**

### **Seats, seat safety belts, harnesses and child restraint devices**

(See JCAR OPS 1.730(a) (3))

#### 1. General

A child restraint device (CRD) is considered to be acceptable if:

- a) It is a ‘supplementary loop belt’ manufactured with the same techniques and the same materials of the approved safety belts; or
- b) It complies with paragraph 2.

#### 2. Acceptable CRDs. Provided the CRD can be installed properly on the respective aircraft seat, the following CRDs are considered “acceptable”:

##### 2.1 Types of CRDs

- a) CRDs approved for use in aircraft only by any JAA authority, the FAA or Transport Canada (on the basis of a national technical standard) and marked accordingly.
- b) CRDs approved for use in motor vehicles according to the UN standard ECE R 44, -03 or later series of Amendments; or
- c) CRDs approved for use in motor vehicles and aircraft according to Canadian CMVSS 213/213.1; or



- d) CRDs approved for use in motor vehicles and aircraft according to US FMVSS No 213 and are manufactured to these standards on or after February 26, 1985. US approved CRDs manufactured after this date must bear the following labels in red lettering:
    - 1) “This child restraint system conforms to all applicable federal motor vehicle safety standards” and
    - 2) “This restraint is certified for use in motor vehicles and aircraft“.
  - e) CRDs qualified for use in aircraft according to the German “Qualification Procedure for Child Restraint Systems for Use in Aircraft“(TÜV Doc.: TÜV/958-01/2001).
- 2.2 Devices approved for use in cars manufactured and tested to standards equivalent to those listed in 2.1 (a) to (e) inclusive, which are acceptable to CARC. The device must be marked with an associated qualification sign, which shows the name of the qualification organization and a specific identification number, related to the associated qualification project.
- 2.3 The qualifying organization shall be a competent and independent organization that is acceptable to CARC.
3. Location
- 3.1 Forward facing CRDs may be installed on both forward and rearward facing passenger seats but only when fitted in the same direction as the passenger seat on which it is positioned. Rearward facing CRDs can only be installed on forward facing passenger seats. A CRD may not be installed within the radius of action of an airbag, unless it is obvious that the airbag is de-activated or it can be demonstrated that there is no negative impact from the airbag.
- 3.2 A child in a restraint device should be located as near to a floor level exit as feasible.
- 3.3 A child in a restraint device should be seated in accordance with JCAR OPS 1.280 and IEM OPS 1.280, “Passenger Seating” so as to not hinder evacuation for any passenger.

- 3.4 A child in a restraint device should neither be located in the row leading to an emergency exit nor located in a row immediately forward or aft of an emergency exit. A window passenger seat is the preferred location. An aisle passenger seat or a cross aisle passenger seat is not recommended. Other locations may be acceptable provided the access of neighbor passengers to the nearest aisle is not obstructed by the CRD.
- 3.5 In general, only one CRD per row segment is recommended. More than one CRD per row segment is allowed if the children are from the same family or travelling group provided the children are accompanied by a responsible person sitting next to them.
- 3.6 A Row Segment is the fraction of a row separated by two aisles or by one aisle and the aircraft fuselage.
4. Installation
  - 4.1 CRDs shall only be installed on a suitable aircraft seat with the type of connecting device they are approved or qualified for. E.g., CRDs to be connected by a three point harness only (most rearward facing baby CRDs currently available) shall not be attached to an aircraft seat with a lap belt only, a CRD designed to be attached to a vehicle seat by means of rigid bar lower anchorages (ISO-FIX or US equivalent) only, shall only be used on aircraft seats that are equipped with such connecting devices and shall not be attached by the aircraft seat lap belt. The method of connecting must be clearly shown in the manufacturer's instructions to be provided with each CRD.
  - 4.2 All safety and installation instructions must be followed carefully by the responsible person accompanying the infant. Cabin crew should prohibit the use of any inadequately installed CRD or not qualified seat.
  - 4.3 If a forward facing CRD with a rigid backrest is to be fastened by a lap belt, the restraint device should be fastened when the backrest of the passenger seat on which it rests is in a reclined position. Thereafter, the backrest is to be positioned upright. This procedure ensures better tightening of the CRD on the aircraft seat if the aircraft seat is recline able.

- 4.4 The buckle of the adult safety belt must be easily accessible for both opening and closing, and must be in line with the seat belt halves (not canted) after tightening.
- 4.5 Forward facing restraint devices with an integral harness must not be installed such that the adult safety belt is secured over the child.
5. Operation
  - 5.1 Each CRD shall remain secured to a passenger seat during all phases of flight, unless it is properly stowed when not in use.
  - 5.2 Where a CRD is adjustable in recline it must be in an upright position for all occasions when passenger restraint devices are required to be used according to JCAR OPS 1.320(b) (1).

## **AMC OPS 1.745**

### **First-Aid Kits**

See JCAR OPS 1.745

The following should be included in the First-Aid Kits:

- Bandages (unspecified)
- Burns dressings (unspecified)
- Wound dressings, large and small
- Adhesive tape, safety pins and scissors
- Small adhesive dressings
- Antiseptic wound cleaner
- Adhesive wound closures
- Adhesive tape
- Disposable resuscitation aid
- Simple analgesic e.g. paracetamol
- Antiemetic e.g. cinnarizine
- Nasal decongestant
- First-Aid handbook
- Gastrointestinal antacid +
- Anti-diarrhoeal medication e.g. Loperamide +
- Ground/Air visual signal code for use by survivors.
- Disposable Gloves

A list of contents in at least 2 languages (English and Arabic), this should include information on the effects and side effects of drugs carried.

NOTE: An eye irrigator whilst not required to be carried in the first-aid kit should, where possible, be available for use on the ground.

+ For airplanes with more than 9 passenger seats installed.

## **AMC OPS 1.755**

### **Emergency Medical Kit**

See JCAR OPS 1.755

The following should be included in the emergency medical kit carried in the airplane:

- Sphygmomanometer – non mercury
- Stethoscope
- Syringes and needles
- Oropharyngeal airways (2 sizes)
- Tourniquet
- Coronary vasodilator e.g. nitro-glycerine
- Anti-spasmodic e.g. hyoscine
- Epinephrine 1:1 000
- Adrenocortical steroid e.g. hydrocortisone
- Major analgesic e.g. nalbuphine
- Diuretic e.g. furosemide
- Antihistamine e.g. diphenhydramine hydrochloride
- Sedative/anticonvulsant e.g. diazepam
- Medication for Hypoglycaemia hypertonic glucose and/or glucagon
- Antiemetic e.g. metoclopramide
- Atropine
- Digoxin
- Disposable Gloves
- Bronchial Dilator – injectable and inhaled form
- Needle Disposal Box
- Catheter

A list of contents in at least 2 languages (English and Arabic), this should include information on the effects and side effects of drugs carried.

## **IEM OPS 1.760**

### **First-aid Oxygen**

See JCAR OPS 1.760

1. First aid oxygen is intended for those passengers who, having been provided with the supplemental oxygen required under JCAR OPS 1.770, still need to breathe undiluted oxygen when the amount of supplemental oxygen has been exhausted.
2. When calculating the amount of first-aid oxygen, an operator should take into account the fact that, following a cabin depressurization, supplemental oxygen as calculated in accordance with Appendix 1 to JCAR OPS 1.770 should be sufficient to cope with hypoxic problems for:
  - a. All passengers when the cabin altitude is above 15 000 ft; and
  - b. A proportion of the passengers carried when the cabin altitude is between 10 000 ft and 15 000 ft.
3. For the above reasons, the amount of first-aid oxygen should be calculated for the part of the flight after cabin depressurization during which the cabin altitude is between 8 000 ft and 15 000 ft, when supplemental oxygen may no longer be available.
4. Moreover, following cabin depressurization an emergency descent should be carried out to the lowest altitude compatible with the safety of the flight. In addition, in these circumstances, the airplane should land at the first available aerodrome at the earliest opportunity.
5. The conditions above should reduce the period of time during which the first-aid oxygen may be required and consequently should limit the amount of first-aid oxygen to be carried on board.

## **IEM OPS 1.770**

### **Supplemental Oxygen – Pressurized Airplanes**

See JCAR OPS 1.770

1. A quick donning mask is the type of mask that:
  - a. Can be placed on the face from its ready position, properly secured, sealed, and supplying oxygen upon demand, with one hand and within 5 seconds and will thereafter remain in position, both hands being free;
  - b. Can be put on without disturbing eye glasses and without delaying the flight crew member from proceeding with assigned emergency duties;
  - c. After being put on, does not prevent immediate communication between the flight crew members and other crew members over the airplane intercommunication system;
  - d. Does not inhibit radio communications.
  
2. In determining the supplemental oxygen for the routes to be flown, it is assumed that the airplane will descend in accordance with the emergency procedures specified in the Operations Manual, without exceeding its operating limitations, to a flight altitude that will allow the flight to be completed safely (ie. flight altitudes ensuring adequate terrain clearance, navigational accuracy, hazardous weather avoidance etc.)

**AC OPS 1.770(b) (2) (v)**

**Supplemental Oxygen - Pressurized Airplanes (Not certificated to fly above 25 000 ft)**

See JCAR OPS 1.770 (b) (2) (v)

1. With respect to JCAR OPS 1.770(b)(2)(v) the maximum altitude up to which an airplane can operate, without a passenger oxygen system installed and capable of providing oxygen to each cabin occupant, should be established using an emergency descent profile which takes into account the following conditions:
  - a. 17 seconds time delay for pilot's recognition and reaction including mask donning, for trouble shooting and configuring the airplane for the emergency descent;
  - b. Maximum operational speed (VMO) or the airspeed approved in the Airplane Flight Manual for emergency descent, whichever is the less;
  - c. All engines operative;
  - d. The estimated mass of the airplane at the top of climb.
- 1.1 Emergency descent data (charts) established by the airplane manufacturer and published in the Airplane Operating Manual and/or Airplane Flight Manual should be used to ensure uniform application of the rule.
2. On routes where the oxygen is necessary to be carried for 10% of the passengers for the flight time between 10 000ft and 13 000ft the oxygen may be provided either:
  - a. By a plug-in or drop-out oxygen system with sufficient outlets and dispensing units uniformly distributed throughout the cabin so as to provide oxygen to each passenger at his own discretion when seated on his assigned seat; or:
  - b. By portable bottles when a fully trained cabin crew member is carried on board of each such flight.

## **AMC OPS 1.790**

### **Hand Fire Extinguishers**

See JCAR OPS 1.790

1. The number and location of hand fire extinguishers should be such as to provide adequate availability for use, account being taken of the number and size of the passenger compartments, the need to minimize the hazard of toxic gas concentrations and the location of toilets, galleys etc. These considerations may result in the number being greater than the minimum prescribed.
2. There should be at least one fire extinguisher suitable for both flammable fluid and electrical equipment fires installed on the flight deck. Additional extinguishers may be required for the protection of other compartments accessible to the crew in flight. Dry chemical fire extinguishers should not be used on the flight deck, or in any compartment not separated by a partition from the flight deck, because of the adverse effect on vision during discharge and, if non-conductive, interference with electrical contacts by the chemical residues.
3. Where only one hand fire extinguisher is required in the passenger compartments it should be located near the cabin crew member's station, where provided.
4. Where two or more hand fire extinguishers are required in the passenger compartments and their location is not otherwise dictated by consideration of paragraph 1 above, an extinguisher should be located near each end of the cabin with the remainder distributed throughout the cabin as evenly as is practicable.
5. Unless an extinguisher is clearly visible, its location should be indicated by a placard or sign. Appropriate symbols may be used to supplement such a placard or sign.



## **AMC OPS 1.810**

### **Megaphones**

See JCAR OPS 1.810

Where one megaphone is required, it should be readily accessible from a cabin crew member's assigned seat. Where two or more megaphones are required, they should be suitably distributed in the passenger cabin(s) and readily accessible to crew members assigned to direct emergency evacuations. This does not necessarily require megaphones to be positioned such that they can be reached by a crew member when strapped in a cabin crew member's seat.

## **AC OPS 1.820**

### **Emergency Locator Transmitter (ELT)**

See JCAR OPS 1.820, JCAR OPS 1.830(c) and JCAR OPS 1.835(b)

1. An Emergency Locator Transmitter (ELT) is a generic term describing equipment which broadcasts distinctive signals on designated frequencies and, depending on application, may be activated by impact or be manually activated. An ELT is one of the following:
  - a. Automatic Fixed (ELT (AF)). An automatically activated ELT which is permanently attached to an aircraft;
  - b. Automatic Portable (ELT (AP)). An automatically activated ELT which is rigidly attached to an aircraft but readily removable from the aircraft;
  - c. Automatic Deployable (ELT (AD)). An ELT which is rigidly attached to the aircraft and which is automatically deployed and activated by impact, and, in some cases, also by hydrostatic sensors, Manual deployment is also provided;
  - d. Survival ELT (ELT(S)). An ELT which is removable from an aircraft, stowed so as to facilitate its ready use in an emergency, and manually activated by survivors.
2. An automatic portable ELT, (ELT(AP)), as installed in accordance with JCAR OPS 1.820, may be used to replace one ELT(S) provided that it meets the ELT(S) requirements. Water activated ELT(S) is not an ELT (AP).

## **IEM OPS 1.825**

### **Life Jackets**

See JCAR OPS 1.825

For the purpose of JCAR OPS 1.825, seat cushions are not considered to be flotation devices.

## **AMC OPS 1.830(b) (2)**

### **Life-rafts and ELT for extended overwater flights**

See JCAR OPS 1.830(b) (2)

1. The following should be readily available with each life-raft:
  - a. Means for maintaining buoyancy;
  - b. A sea anchor;
  - c. Life-lines and means of attaching one life-raft to another;
  - d. Paddles for life-rafts with a capacity of 6 or less;
  - e. Means of protecting the occupants from the elements;
  - f. A water resistant torch;
  - g. Signaling equipment to make the pyrotechnical distress signals described in ICAO Annex 2;
  - h. 100 g of glucose tablet for each 4, or fraction of 4, persons which the life-raft is designed to carry;
  - i. At least 2 liters of drinkable water provided in durable containers or means of making sea water drinkable or a combination of both; and
  - j. First-aid equipment.
2. As far as practicable, items listed above should be contained in a pack.

## **IEM OPS 1.835**

### **Survival Equipment**

See JCAR OPS 1.835

1. The expression ‘Areas in which search and rescue would be especially difficult’ should be interpreted in the context of this JCAR as meaning:
  - a. Areas so designated by the State responsible for managing search and rescue; or
  - b. Areas that are largely uninhabited and where:
    - i. The State responsible for managing search and rescue has not published any information to confirm that search and rescue would not be especially difficult; and
    - ii. The State referred to in (a) above does not, as a matter of policy, designate areas as being especially difficult for search and rescue.

## **AMC OPS 1.835(c)**

### **Survival Equipment**

See JCAR OPS 1.835(c)

1. At least the following survival equipment should be carried when required:
  - a. 2 liters of drinkable water for each 50, or fraction of 50, persons on board provided in durable containers;
  - b. One knife;
  - c. One set of Air/Ground codes; In addition, when polar conditions are expected, the following should be carried:
  - d. A means for melting snow;
  - e. Sleeping bags for use by 1/3 of all persons on board and space blankets for the remainder or space blankets for all passengers on board;
  - f. 1 Arctic/Polar suit for each crew member carried.
2. If any item of equipment contained in the above list is already carried on board the airplane in accordance with another requirement, there is no need for this to be duplicated.

## Appendix 1 to AC OPS 1.720 /1.725

### Parameters to be recorded

See AC OPS 1.720 /1.725

**TABLE 1 – Parameters Performance Specifications**

Serial No.	Parameter	Range	Sampling Interval in seconds	Accuracy limits (sensor input compared to FDR readout)	Recommended Resolution in readout	Remarks
1	Time or relative time count	24 hours	4	±0.125% per hour	1 second	UTC time preferred where available, otherwise elapsed time
2	Pressured altitude	-1 000 ft to maximum certificated altitude of aircraft +5000 ft	1	±100 ft to ±700 ft	5 ft	For altitude record error see JAR JTSO C124
3	Indicated airspeed	50 kt to max $V_{SO}$ Max $V_{SO}$ to 1.2 $V_d$	1	±5% ±3 %	1kt	$V_{ES}$ stalling speed or minimum steady flight speed in the landing configuration $V_{LS}$ design diving speed
4	Heading	360°	1	±2°	0.5°	
5	Normal acceleration	-3 g to +6 g	0.125 ±	0.125 ±1% of maximum range excluding a datum error of ± 5%	0.004 g	
6	Pitch attitude	±75°	1	±2°	0.5°	
7	Roll attitude	±180°	1	±2°	0.5°	
8	Manual radio transmission keying	Discrete	1	-	-	On-off (one discrete). An FDR/CVR time synchronisation signal complying with EUROCAE Document ED55 dated May 1990 paragraph 4.2.1 is an acceptable alternative means of compliance
9	Power on each engine	Full range	Each engine each second	±2%	0.2% of full range	Sufficient parameters e.g. EPRM, or Torque/ $N_p$ as appropriate to the particular engine should be recorded to determine power
10	Trailing edge flap or cockpit control selection	Full range or each discrete position	2	±5% or as pilot's indicator	0.5% of full range	
11	Leading edge flap or cockpit control selection	Full range or each discrete position	2	-	0.5% of full range	
12	Thrust reverser position	Stowed, in transit, and reverse	Each reverser each second	±2% unless higher accuracy uniquely required	-	
13	Ground spoiler and/or speed brake selection	Full range or each discrete position	1	±2°	0.2% of full range	
14	Outside air temperatures or Total air temperature	Sensor range	2	-	0.3°	
15a	Autopilot engagement status					
15b	Autopilot operating modes; autothrottle and AFCS systems engagement status and operating modes	A suitable combination of discretely	1			

Appendix 1 to AC OPS 1.720 /1.725 Continue

TABLE 1 – Parameters Performance Specifications

Serial No.	Parameter	Range	Sampling Interval in seconds	Accuracy limits (sensor input compared to FDR readout)	Recommended Resolution in readout	Remarks
16	Longitudinal acceleration	± 1 g	0.25	± 1.5% of maximum range excluding a datum error of ± 5%	0.004 g	
17	Lateral acceleration	± 1 g	0.25	± 1.5% of maximum range excluding a datum error of ±5%	0.004 g	
18	Primary flight controls, Control surface positions and/or pilot input (pitch, roll, yaw)	Full range	1	±2% unless higher accuracy uniquely required	0.2% of full range	For aeroplanes with conventional control systems 'or' applies For aeroplanes with non-mechanical control systems 'and' applies For aeroplanes with split surfaces a suitable combination of inputs is acceptable in lieu of recording each surface separately
19	Pitch trim position	Full range	1	±3% unless higher accuracy uniquely required	0.3% of full range	
20	Radio altitude	-20 ft to +2500 ft	1	±2 ft or ±3% whichever is greater below 500 ft and ±5% above 500 ft	1 ft below 500 ft, 1 ft +5% of full range above 500 ft	As installed. Accuracy limits are recommended
21	Glide path deviation	Signal range	1	±3%	0.3% of full range	As installed. Accuracy limits are recommended
22	Localiser deviation	Signal range	1	±3%	0.3% of full range	As installed. Accuracy limits are recommended
23	Marker beacon passage	Discrete	1	-	-	A single discrete is acceptable for all markers
24	Master warning	Discrete	1	-	-	
25	NAV 1 and 2 frequency selection	Full range	4	As installed	-	
26	DME 1 and 2 distance	0-200 nm	4	As installed	-	Recording of latitude and longitude from INS or other navigation system is a preferred alternative
27	Landing gear squat switch status	Discrete	1	-	-	
28	Ground proximity warning system (GPWS)	Discrete	1	-	-	
29	Angle of attack	Full range	0.5	As installed	0.3% of full range	
30	Hydraulics	Discrete(s)	2	-	-	
31	Navigation data	As installed	1	As installed	-	
32	Landing gear or gear selector position	Discrete	4	As installed	-	

## **Appendix 1 to AC OPS 1.720 /1.725 Continue**

### **TABLE B – Additional information to be considered**

- (a) Operational information from electronic display systems, such as Electronic Flight Instruments Systems (EFIS), Electronic Centralized Aircraft Monitor (ECAM) and Engine Indications and Crew Alerting System (EICAS). Use the following order of priority:
1. Parameters selected by the flight crew relating to the desired flight path, e.g. barometric pressure setting, selected altitude, selected airspeed, decision height, and auto flight system engagement and mode indications if not recorded from another source;
  2. Display system selection/status, e.g. SECTOR, PLAN, ROSE, NAV, WXR, COMPOSITE, COPY;
  3. Warnings and alerts;
  4. The identity of displayed pages for emergency procedures and checklists.
- (b) Retardation information including brake application for use in the investigation of landing over-runs and rejected take-offs; and
- (c) Additional engine parameters (EPR, N1 EGT, fuel flow, etc.).

## **ACJ/AMC/IEM L**

### **Communication and Navigation Equipment**

#### **IEM OPS 1.845**

#### **Communication and Navigation Equipment - Approval and Installation**

See JCAR OPS 1.845

1. For Communication and Navigation Equipment required by JCAR OPS 1 Subpart L, “Approved” means that compliance with the applicable TSO design requirements and performance specifications, or equivalent, in force at the time of the equipment approval application, have been demonstrated. Where a TSO does not exist, the applicable airworthiness standards or equivalent apply unless otherwise prescribed in JCAR OPS 1.
2. “Installed” means that the installation of Communication and Navigation Equipment has been demonstrated to comply with the applicable airworthiness requirements of JCAR CS 23 / JCAR CS 25, or the relevant code used for Type Certification, and any applicable requirement prescribed in JCAR OPS 1.
3. Communication and Navigation Equipment approved in accordance with design requirements and performance specifications other than TSOs, before the applicability dates prescribed in JCAR OPS 1.001(b), are acceptable for use or installation on airplanes operated for the purpose of commercial air transportation provided that any relevant JCAR OPS requirement is complied with.
4. When a new version of a TSO (or of a specification other than a TSO) is issued, Communication and Navigation Equipment approved in accordance with earlier requirements may be used or installed on airplanes operated for the purpose of commercial air transportation provided that such Communication and Navigation Equipment are operational, unless removal from service or withdrawal is required by means of an amendment to JCAR OPS 1.

## **AMC OPS 1.865**

### **Combinations of Instruments and Integrated Flight Systems**

See JCAR OPS 1.865

Individual requirements of JCAR OPS 1.865 may be met by combinations of instruments or by integrated flight systems or by a combination of parameters on electronic displays provided that the information so available to each required pilot is not less than that provided by the instruments and associated equipment specified.

### **AC OPS 1.865(c) (1) (i)**

#### **IFR operations without ADF system**

See JCAR OPS 1.865(c) (1) (i)

1. To perform IFR operations without an ADF system installed, an operator should consider the following guidelines on equipment carriage, operational procedures and training criteria.
2. The removal/non installation of ADF equipment from an airplane may only be done where it is not essential for navigation, provided that alternative equipment giving equivalent or enhanced navigation capability is carried. This may be accomplished by the carriage of an additional VOR receiver or a GNSS receiver approved for IFR operations.
3. For IFR operations without ADF, an operator should ensure that:
  - a. Route segments that rely solely on ADF for navigation are not flown;
  - b. A firm commitment is made not to fly any ADF/NDB procedures;
  - c. That the MEL has been amended to take account of the non-carriage of ADF;
  - d. That the Operations Manual does not reference any procedures based on NDB signals for the airplanes concerned;
  - e. That flight planning and dispatch procedures are consistent with the above mentioned criteria
4. The removal of ADF should be taken into account by the operator in the initial and recurrent training of flight crew.



## **AC OPS 1.865(e)**

### **FM Immunity Equipment Standards**

See JCAR OPS 1.865(e)

1. FM immunity performance Standards for ILS Localizer, VOR receivers and VHF communication receivers have been incorporated in ICAO Annex 10, Volume I - Radio Navigation Aids Fifth Edition dated July 1996, Chapter 3, Paragraphs 3.1.4, 3.3.8 and Volume III, Part II - Voice Communications Systems, Paragraph 2.3.3.
2. Acceptable equipment standards, consistent with ICAO Annex 10, are contained in EUROCAE Minimum Operational Performance Specifications, documents ED-22B for VOR receivers, ED-23B for VHF communication receivers and ED-46B for LOC receivers and the corresponding RTCA documents DO-186, DO-195 and DO-196.

## **AC OPS 1.865(f)**

### **HF - Equipment on certain MNPS Routes**

See JCAR OPS 1.865(f)

1. An HF - system is considered to be Long Range Communication Equipment.
2. Other two way communication systems may be used if allowed by the relevant airspace procedures.
3. When using one communication system only, CARC may restrict the MNPS approval to the use of the specific routes.

## **AC OPS 1.870**

### **Additional Navigation Equipment for operations in MNPS Airspace**

See JCAR OPS 1.870

1. A Long Range Navigation System may be one of the following:
  - a. One Inertial Navigation System (INS).
  - b. One Global Navigation Satellite System (GNSS).
  - c. One navigation system using inputs from one or more Inertial Reference Systems (IRS), or any other MNPS approved sensor system.

2. To conform to the Long Range Navigation System Specification, a GNSS and its operational use should be approved in accordance with the relevant requirements for MNPS airspace.
3. An integrated navigation system which offers equivalent functional availability, integrity and redundancy, when approved may, for the purpose of this requirement, be considered as two independent Long Range Navigation Systems.

## **AC OPS 1.873**

### **Electronic navigation data management**

See JCAR OPS 1.873

1. Terminology
  - a. Navigation Database. Data (such as navigation information, flight planning waypoints, airways, navigation facilities, SID, STAR) that is stored electronically in a system that supports an airborne navigation application.
  - b. Navigation Database Supplier. The meaning of navigation database supplier in JCAR OPS 1.873 is equivalent to data application integrator (Refer to EASA OPINION Nr. 01/2005 on “The Acceptance of Navigation Database Suppliers” dated 14 January 2005).
  - c. Data Application Integrator. An organization that incorporates either State AIP (Aeronautical Information Publication) data or a generic database into a format compatible with specific target airborne navigation equipment with a defined intended function, Such organizations require an interface with the equipment design organization, and are eligible for a Type 2 Letter of Acceptance (LoA) under the Conditions for issuance of LoA for Navigation Database Suppliers by EASA (See paragraph 5.7 of “Guidance to Agency Conditions for Issue of a LoA for Navigation Database Suppliers”). This provides a list of equipment models and part numbers where compatibility has been demonstrated to the Agency, permitting the supply of navigation databases directly to end users/operators.

- d. Type 2 LoA. LoA granted where a navigation database supplier complies with ED-76/DO-200A and provides data compatible with specified avionics system(s). A Type 2 LoA confirms that the processes for producing navigation data comply with these conditions and the documented Data Quality Requirements for the avionics systems specified. The Data Quality Requirements must be provided by or agreed with the specified equipment design organization in accordance with a formal arrangement. A Type 2 LoA may release navigation databases directly to end users. Such releases may also include data packing tools, where the use of such tools has been demonstrated to be ED-76/DO-200A compliant. A Type 2 LoA holder may interface directly with data originators (such as State AIP providers and operators), or may use data supplied by a Type 1 LoA, in which case interfaces with data originators may not be necessary.
- e. Type 1 LoA. LoA granted where a navigation database supplier complies with ED-76/DO-200A with no identified compatibility with an aircraft system. A Type 1 LoA confirms that the processes for producing navigation data comply with these conditions and the documented Data Quality Requirements. A Type 1 LoA may not release navigation databases directly to end users.

Note: The term “navigation database supplier” in the Type 1 LoA above is equivalent to “Data Service Provider” as defined in “EASA Conditions for Issue of a LoA for Navigation Database Suppliers”.

- f. Data Service Provider. An organization (not including the State AIP provider), which collects, originates or processes aeronautical data and provides a navigation database in a generic format (such as ARINC 424). Such organizations are eligible for a Type 1 LoA under the Conditions for issuance of LoA for Navigation Database Suppliers by EASA (See paragraph 5.7 of “Guidance to Agency Conditions for Issue of an LoA for Navigation Database Suppliers”), showing that the generic database has been formatted under controlled conditions.
2. An EASA Type 2 LoA is issued by EASA in accordance with EASA OPINION Nr. 01/2005 on “The Acceptance of Navigation Database Suppliers” dated 14 Jan 05.

3. The FAA issues a Type 2 LoA in accordance with AC 20-153, while Transport Canada (TCCA) is issuing an Acknowledgement Letter of an Aeronautical Data Process using the same basis. Both acknowledgments are Seen to be equivalent to the EASA LoA.
4. EUROCAE/RTCA document ED-76/DO-200A Standards for Processing Aeronautical Data contains guidance relating to the processes that the supplier may follow.
5. The ultimate responsibility for ensuring that the data meets the quality for its intended application rests with the end-user of that data. This responsibility can be met by obtaining data from a supplier accredited against this standard by an appropriate organization. This does not alter the supplier's responsibility for any functions performed on the data.

**AC/AMC/IEM M**  
**Airplane Maintenance**

This Subpart has been entirely withdrawn due to the implementation of JCAR Part M

**AC/AMC/IEM N**  
**Flight Crew**

**AMC OPS 1.940(a) (4)**

**Crewing of inexperienced flight crew members**

See JCAR OPS 1.940(a) (4)

1. An operator should consider that a flight crew member is inexperienced, following completion of a Type Rating or command course, and the associated line flying under supervision, until he has achieved on the Type either:
  - a. 100 flying hours and flown 10 sectors within a consolidation period of 120 consecutive days; or
  - b. 150 flying hours and flown 20 sectors (no time limit).
2. A lesser number of flying hours or sectors, subject to any other conditions which CARC may impose, may be acceptable to CARC when:
  - a. A new operator is commencing operations; or
  - b. An operator introduces a new airplane type; or
  - c. Flight crew members have previously completed a type conversion course with the same operator; or
  - d. The airplane has a Maximum Take-off Mass below 10 tones or a Maximum Approved Passenger Seating Configuration of less than 20

## **AMC OPS 1.945**

### **Conversion Course Syllabus**

See JCAR OPS 1.945 & Appendix 1 to JCAR OPS 1.945

1. General
  - 1.1 Type rating training when required may be conducted separately or as part of conversion training. When the type rating training is conducted as part of conversion training, the conversion training program should include all the requirements of JCAR FCL.
2. Ground training
  - 2.1 Ground training should comprise a properly organized program of ground instruction by training staff with adequate facilities, including any necessary audio, mechanical and visual aids. However, if the airplane concerned is relatively simple, private study may be adequate if the operator provides suitable manuals and/or study notes.
  - 2.2 The course of ground instruction should incorporate formal tests on such matters as airplane systems, performance and flight planning, where applicable.
3. Emergency and safety equipment training and checking
  - 3.1 On the initial conversion course and on subsequent conversion courses as applicable, the following should be addressed:
    - a. Instruction on first aid in general (Initial conversion course only); Instruction on first aid as relevant to the airplane type of operation and crew complement including where no cabin crew are required to be carried (Initial and subsequent);
    - b. Aero medical topics including:
      - i. Hypoxia;
      - ii. Hyperventilation;
      - iii. Contamination of the skin/eyes by aviation fuel or hydraulic or other fluids;
      - iv. Hygiene and food poisoning; and
      - v. Malaria;

- c. The effect of smoke in an enclosed area and actual use of all relevant equipment in a simulated smoke-filled environment;
  - d. The operational procedures of security, rescue and emergency services.
  - e. Survival information appropriate to their areas of operation (e.g. polar, desert, jungle or sea) and training in the use of any survival equipment required to be carried.
  - f. A comprehensive drill to cover all ditching procedures should be practiced where flotation equipment is carried. This should include practice of the actual donning and inflation of a lifejacket, together with a demonstration or film of the inflation of life-rafts and/or slide-rafts and associated equipment. This practice should, on an initial conversion course, be conducted using the equipment in water, although previous certificated training with another operator or the use of similar equipment will be accepted in lieu of further wet-drill training.
  - g. Instruction on the location of emergency and safety equipment, correct use of all appropriate drills, and procedures that could be required of flight crew in different emergency situations. Evacuation of the airplane (or a representative training device) by use of a slide where fitted should be included when the Operations Manual procedure requires the early evacuation of flight crew to assist on the ground.
4. Airplane/FSTD (A) training.
- 4.1 Flying training should be structured and sufficiently comprehensive to familiarize the flight crew member thoroughly with all aspects of limitations and normal /abnormal and emergency procedures associated with the airplane and should be carried out by suitably qualified Type Rating Instructors and/or Type Rating Examiners. For specialized operations such as steep approaches, ETOPS, All Weather Operations, or QFE operations, additional training should be carried out.



- 4.2 In planning airplane/FSTD (A) training on airplanes with a flight crew of two or more, particular emphasis should be placed on the practice of Line Orientated Flying Training (LOFT) with emphasis on Crew Resource Management (CRM).
- 4.3 Normally, the same training and practice in the flying of the airplane should be given to copilots as well as commanders. The ‘flight handling’ sections of the syllabus for commanders and copilots alike should include all the requirements of the operator proficiency check required by JCAR OPS 1.965.
- 4.4 Unless the type rating training program has been carried out in a Flight Simulator usable for zero flight-time (ZFT) conversion, the training should include at least 3 takeoffs and landings in the airplane.
5. Line flying under supervision
  - 5.1 Following completion of airplane/FSTD (A) training and checking as part of the operator’s conversion course, each flight crew member should operate a minimum number of sectors and/or flying hours under the supervision of a flight crew member nominated by the operator and acceptable to CARC.
  - 5.2 The minimum sectors/hours should be specified in the Operations Manual and should be determined by the following:
    - a. Previous experience of the flight crew member;
    - b. Complexity of the airplane; and
    - c. The type and area of operation.
  - 5.3 A line check in accordance with JCAR OPS 1.945(a) (8) should be completed upon completion of line flying under supervision.

6. System Panel Operator

6.1 Conversion training for system panel operators should approximate to that of pilots.

6.2 If the flight crew includes a pilot with duties of a systems panel operator, he should, after training and the initial check in these duties, operate a minimum number of sectors under the supervision of a nominated additional flight crew member. The minimum figures should be specified in the Operations Manual and should be selected after due note has been taken of the complexity of the airplane and the experience of the flight crew member.

**IEM OPS 1.945**

**Line Flying under Supervision**

See JCAR OPS 1.945

1. Introduction

1.1 Line flying under supervision provides the opportunity for a flight crew member to carry into practice the procedures and techniques he has been made familiar with during the ground and flying training of a conversion course. This is accomplished under the supervision of a flight crew member specifically nominated and trained for the task. At the end of line flying under supervision the respective crew member should be able to perform a safe and efficient flight conducted within the tasks of his crewmember station.

1.2 The following minimum figures for details to be flown under supervision are guidelines for operators to use when establishing their individual requirements.

2. Turbo jet aircraft

a. Co-pilot undertaking first conversion course:

i. Total accumulated 100 hours or minimum 40 sectors;

b. Co-pilot upgrading to commander:

i. Minimum 20 sectors when converting to a new type;

ii. Minimum 10 sectors when already qualified on the airplane type.

## **AC OPS AMC 1.943/1.945 (a) (9)/1.955(b) (6)/1.965(e)**

### **Crew Resource Management (CRM)**

See JCAR OPS 1.943/1.945 (a) (9)/1.955(b) (6)/1.965(e)/1.965(a) (3) (iv)

See AC OPS IEM 1.943/1.945 (a) (9)/1.955(b) (6)/1.965(e)

#### 1. General

1.1 Crew Resource Management (CRM) is the effective utilization of all available resources (e.g. crew members, airplane systems, supporting facilities and persons) to achieve safe and efficient operation.

1.2 The objective of CRM is to enhance the communication and management skills of the flight crew member concerned. The emphasis is placed on the non-technical aspects of flight crew performance.

#### 2. Initial CRM Training

2.1 Initial CRM training programs are designed to provide knowledge of, and familiarity with, human factors relevant to flight operations. The course duration should be a minimum of one day for single pilot operations and two days for all other types of operations. It should cover all elements in Table 1, column (a) to the level required by column (b) (Initial CRM training).

2.2 a. A CRM trainer should possess group facilitation skills and should at least:

i. Have current commercial air transport experience as a flight crew member; and have either:

(A) Successfully passed the Human Performance and Limitations (HPL) examination whilst recently obtaining the ATPL (See the requirements applicable to the issue of Flight Crew Licenses); or,

(B) If holding a Flight Crew License acceptable under JCAR OPS 1.940(a) (3) prior to the introduction of HPL into the ATPL syllabus, followed a theoretical HPL course covering the whole syllabus of the HPL examination.

ii. Have completed initial CRM training; and

- iii. Be supervised by suitably qualified CRM training personnel when conducting their first initial CRM training session; and
  - iv. Have received additional education in the fields of group management, group dynamics and personal awareness.
- b. Notwithstanding paragraph (a) above, and when acceptable to CARC;
- i. A flight crew member holding a recent qualification as a CRM trainer may continue to be a CRM trainer even after the cessation of active flying duties;
  - ii. An experienced non-flight crew CRM trainer having knowledge of HPL may also continue to be a CRM trainer;
  - iii. A former flight crew member having knowledge of HPL may become a CRM trainer if he maintains adequate knowledge of the operation and airplane type and meets the provisions of paragraphs 2.2a ii, iii and iv.
- 2.3 An operator should ensure that initial CRM training addresses the nature of the operations of the company concerned, as well as the associated procedures and the culture of the company. This will include areas of operations which produce particular difficulties or involve adverse climatic conditions and any unusual hazards.
- 2.4 If the operator does not have sufficient means to establish initial CRM training, use may be made of a course provided by another operator, or a third party or training organization acceptable to CARC. In this event the operator should ensure that the content of the course meets his operational requirements. When crew members from several companies follow the same course, CRM core elements should be specific to the nature of operations of the companies and the trainees concerned.
- 2.5 A flight crew member's CRM skills should not be assessed during initial CRM training.

3 Conversion Course CRM training

- 3.1 If the flight crew member undergoes a conversion course with a change of airplane type, all elements in Table 1, column (a) should be integrated into all appropriate phases of the operator's conversion course and covered to the level required by column (c) (conversion course when changing type), unless the two operators use the same CRM training provider.
- 3.2 If the flight crew member undergoes a conversion course with a change of operator, all elements in Table 1, column (a) should be integrated into all appropriate phases of the operator's conversion course and covered to the level required by column (d) (conversion course when changing operator).
- 3.3 A flight crew member should not be assessed when completing elements of CRM training which are part of an operator's conversion course.

4. Command course CRM training

- 4.1 An operator should ensure that all elements in Table 1, column (a) are integrated into the command course and covered to the level required by column (e) (command course).
- 4.2 A flight crew member should not be assessed when completing elements of CRM training which are part of the command course, although feedback should be given.

5. Recurrent CRM training

- 5.1 An operator should ensure that:
  - a. Elements of CRM are integrated into all appropriate phases of recurrent training every year; and that all elements in Table 1, column (a) are covered to the level required by column (f) (recurrent training); and that modular CRM training covers the same areas over a maximum period of 3 years.
  - b. Relevant modular CRM training is conducted by CRM trainers qualified according to paragraph 2.2.
- 5.2 A flight crew member should not be assessed when completing elements of CRM training which are part of recurrent training.

6. Implementation of CRM

6.1 The following table indicates which elements of CRM should be included in each type of training:

**Table 1**

Core Elements (a)	Initial CRM Training (b)	Operator's conversion course when changing type (c)	Operator's conversion course when changing operator (d)	Command course (e)	Recurrent Training (f)
Human error and reliability, error chain, error prevention and detection	In depth	In depth	Overview	Overview	Overview
Company safety culture, Sops, organizational factors		Not required	In depth	In depth	
Stress, stress management, fatigue & vigilance			Overview		
Information acquisition and processing situation awareness, workload management		Overview		Overview	
Decision making				Overview	
Communication and coordination inside and outside the cockpit		Overview			
Leadership and team behavior synergy	As required	In depth	In depth	As required	As required
Automation, philosophy of the use of automation (if relevant to the type)		In depth	As required		
Specific type-related differences	In depth	In depth	Not required	In depth	As appropriate
Case based studies			In depth		

7. Co-ordination between flight crew and cabin crew training

7.1 Operators should, as far as is practicable, provide combined training for flight crew and cabin crew including briefing and debriefing.

7.2 There should be an effective liaison between flight crew and cabin crew training departments. Provision should be made for flight and cabin crew instructors to observe and comment on each other's training.

8. Assessment of CRM Skills (See AC OPS IEM1.943/1.945 (a) (9) / 1.955 (b) (6)/1.965(e), paragraph 4)

8.1 Assessment of CRM skills should:

- a. Provide feedback to the crew and the individual and serve to identify retraining where needed; and
- b. Be used to improve the CRM training system.

- 8.2 Prior to the introduction of CRM skills assessment, a detailed description of the CRM methodology including terminology used, acceptable to CARC, should be published in the Operations Manual.
- 8.3 Operators should establish procedures, including retraining, to be applied in the event that personnel do not achieve or maintain the required standards (Appendix 1 to OPS 1.1045, Section D, paragraph 3.2 refers).
- 8.4 If the operator proficiency check is combined with the Type Rating revalidation / renewal check, the assessment of CRM skills will satisfy the Multi Crew Co-operation requirements of the Type Rating revalidation / renewal. This assessment will not affect the validity of the Type Rating.

**AC OPS IEM 1.943/1.945 (a) (9)/1.955(b) (6)/1.965(e)**

**Crew Resource Management (CRM)**

See JCAR OPS 1.943/1.945 (a) (9)/1.955(b) (6)/1.965(e)

See AC OPS AMC 1.943/1.945 (a) (9)/1.955(b) (6)/1.965(e)

1. CRM training should reflect the culture of the operator and be conducted by means of both classroom training and practical exercises including group discussions and accident and serious incident reviews to analyze communication problems and instances or examples of a lack of information or crew management.
2. Whenever it is practicable to do so, consideration should be given to conducting relevant parts of CRM training in synthetic training devices which reproduce, in an acceptable way, a realistic operational environment and permit interaction. This includes, but is not limited to, simulators with appropriate LOFT scenarios.
3. It is recommended that, whenever possible, initial CRM training be conducted in a group session outside the company premises so that the opportunity is provided for flight crew members to interact and communicate away from the pressures of their usual working environment.

4. Assessment of CRM Skills

4.1 Assessment of CRM skills is the process of observing, recording, interpreting and debriefing crews' and crew member's performance and knowledge using an acceptable methodology in the context of overall performance. It includes the concept of self-critique, and feedback which can be given continuously during training or in summary following a check. In order to enhance the effectiveness of the program this methodology should, where possible, be agreed with flight crew representatives.

4.2 NOTECHS or other acceptable methods of assessment should be used. The selection criteria and training requirements of the assessors and their relevant qualifications, knowledge and skills should be established.

4.3 Methodology of CRM skills assessment:

a. An operator should establish the CRM training program including an agreed terminology. This should be evaluated with regard to methods, length of training, depth of subjects and effectiveness.

b. A training and standardization program for training personnel should then be established.

c. The assessment should be based on the following principles:

i. Only observable, repetitive behaviors are assessed,

ii. The assessment should positively reflect any CRM skills that result in enhanced safety,

iii. Assessments should include behavior which contributes to a technical failure, such technical failure being errors leading to an event which requires debriefing by the person conducting the line check,

iv. The crew and, where needed, the individual are orally debriefed.



- 4.4 De-identified summaries of all CRM assessments by the operator should be used to provide feedback to update and improve the operator's CRM training.
5. Levels of Training.
  - a. Overview. When Overview training is required it will normally be instructional in style. Such training should refresh knowledge gained in earlier training.
  - b. In Depth. When In Depth Training is required it will normally be interactive in style and should include, as appropriate, case studies, group discussions, role play and consolidation of knowledge and skills. Core elements should be tailored to the specific needs of the training phase being undertaken.

### **AMC OPS 1.945(a) (9)**

#### **Crew Resource Management - Use of Automation**

See JCAR OPS 1.945(a) (9)

1. The conversion course should include training in the use and knowledge of automation and in the recognition of systems and human limitations associated with the use of automation. An operator should therefore ensure that a flight crew member receives training on:
  - a. The application of the operations policy concerning the use of automation as stated in the Operations Manual; and
  - b. System and human limitations associated with the use of automation.
2. The objective of this training should be to provide appropriate knowledge, skills and behavioral patterns for managing and operating automated systems. Special attention should be given to how automation increases the need for crews to have a common understanding of the way in which the system performs, and any features of automation which make this understanding difficult

## **AMC OPS 1.965(c)**

### **Line checks**

See JCAR OPS 1.965(c)

1. Where a pilot is required to operate as pilot flying and pilot non-flying, he should be checked on one sector as pilot flying and on another sector as pilot non-flying.
2. However, where an operator's procedures require integrated flight preparation, integrated cockpit initialization and that each pilot performs both flying and non-flying duties on the same sector, then the line check may be performed on a single sector.

## **AMC OPS 1.965(d)**

### **Emergency and Safety Equipment Training**

See JCAR OPS 1.965(d)

1. The successful resolution of airplane emergencies requires interaction between flight crew and cabin crew and emphasis should be placed on the importance of effective coordination and two-way communication between all crew members in various emergency situations.
2. Emergency and Safety Equipment training should include joint practice in airplane evacuations so that all who are involved are aware of the duties other crew members should perform. When such practice is not possible, combined flight crew and cabin crew training should include joint discussion of emergency scenarios.
3. Emergency and safety equipment training should, as far as is practicable, take place in conjunction with cabin crew undergoing similar training with emphasis on coordinated procedures and two-way communication between the flight deck and the cabin.

## **IEM OPS 1.965**

### **Recurrent training and checking**

See JCAR OPS 1.965

1. Line checks, route and aerodrome competency and recent experience requirements are intended to ensure the crew member's ability to operate efficiently under normal conditions, whereas other checks and emergency and safety equipment training are primarily intended to prepare the crew member for abnormal/emergency procedures.
2. The line check is performed in the airplane. All other training and checking should be performed in the airplane of the same type or an FSTD (A) or, an approved flight simulator or, in the case of emergency and safety equipment training, in a representative training device. The type of equipment used for training and checking should be representative of the instrumentation, equipment and layout of the airplane type operated by the flight crew member.
3. Line Checks
  - 3.1 The line check is considered a particularly important factor in the development, maintenance and refinement of high operating standards, and can provide the operator with a valuable indication of the usefulness of his training policy and methods. Line checks are a test of a flight crew member's ability to perform a complete line operation satisfactorily, including preflight and post flight procedures and use of the equipment provided, and an opportunity for an overall assessment of his ability to perform the duties required as specified in the Operations Manual. The route chosen should be such as to give adequate representation of the scope of a pilot's normal operations. When weather conditions preclude a manual landing, an automatic landing is acceptable. The line check is not intended to determine competence on any particular route. The commander, or any pilot who may be required to relieve the commander, should also demonstrate his ability to 'manage' the operation and take appropriate command decisions.
4. Proficiency Training and Checking
  - 4.1 When an FSTD (A) is used, the opportunity should be taken, where possible, to use Line Oriented Flying Training (LOFT).
  - 4.2 Proficiency training and checking for System Panel Operators should, where practicable, take place at the same time a pilot is undergoing proficiency training and checking.

## **AMC to Appendix 1 to JCAR OPS 1.965**

### **Pilot incapacitation training**

See Appendix 1 to JCAR OPS 1.965; paragraph (a) (1)

1. Procedures should be established to train flight crew to recognize and handle pilot incapacitation. This training should be conducted every year and can form part of other recurrent training. It should take the form of classroom instruction, discussion or video or other similar means.
2. If a Flight Simulator is available for the type of airplane operated, practical training on pilot incapacitation should be carried out at intervals not exceeding 3 years.

## **AMC OPS 1.970**

### **Recency**

See JCAR OPS 1.970

When using a Flight Simulator for meeting the landing requirements in JCAR OPS 1.970(a) (1) and (a) (2), complete visual traffic patterns or complete IFR procedures starting from the Initial Approach Fix should be flown.

## **IEM OPS 1.970(a) (2)**

### **Co-pilot proficiency**

See JCAR OPS 1.970(a) (2)

A co-pilot serving at the controls means that that pilot is either pilot flying or pilot non-flying. The only required take-off and landing proficiency for a co-pilot is the operator's and JCAR FCL type rating proficiency checks.

## **AMC OPS 1.975**

### **Route and aerodrome competence qualification**

See JCAR OPS 1.975

1. Route competence
  - 1.1 Route competence training should include knowledge of:
    - a. Terrain and minimum safe altitudes;
    - b. Seasonal meteorological conditions;

- c. Meteorological, communication and air traffic facilities, services and procedures;
  - d. Search and rescue procedures; and
  - e. Navigational facilities associated with the route along which the flight is to take place.
- 1.2 Depending on the complexity of the route, as assessed by the operator, the following methods of familiarization should be used:
- a. For the less complex routes, familiarization by self-briefing with route documentation, or by means of programmed instruction; and
  - b. For the more complex routes, in addition to sub-paragraph 1.2.a above, in flight familiarization as a commander, co-pilot or observers under supervision, or familiarization in a Synthetic Training Device using a database appropriate to the route concerned.
2. Aerodrome competence
- 2.1 The Operations Manual should specify a method of categorization of aerodromes and specify the requirements necessary for each of these categories. If the least demanding aerodromes are Category A, Category B and C would be applied to progressively more demanding aerodromes. The Operations Manual should specify the parameters which qualify an aerodrome to be considered Category A and then provide a list of those aerodromes categorized as B or C.
- 2.2 All aerodromes to which an operator operates should be categorized in one of these three categories. The operator's categorization should be acceptable to CARC.
3. Category A. An aerodrome which satisfies all of the following requirements:
- a. An approved instrument approach procedure;
  - b. At least one runway with no performance limited procedure for take-off and/or landing;

- c. Published circling minima not higher than 1 000 feet above aerodrome level; and
  - d. Night operations capability.
4. Category B. An aerodrome which does not satisfy the Category A requirements or which requires extra considerations such as:
- a. Non-standard approach aids and/or approach patterns; or
  - b. Unusual local weather conditions; or
  - c. Unusual characteristics or performance limitations; or
  - d. Any other relevant considerations including obstructions, physical layout, lighting etc.
- 4.1 Prior to operating to a Category B aerodrome, the commander should be briefed, or self-briefed by means of programmed instruction, on the Category B aerodrome(s) concerned and should certify that he has carried out these instructions.
5. Category C. An aerodrome which requires additional considerations to a Category B aerodrome
- 5.1 Prior to operating to a Category C aerodrome, the commander should be briefed and visit the aerodrome as an observer and/or undertake instruction in a Flight Simulator. This instruction should be certified by the operator.

## **AC OPS 1.978**

### **Terminology**

See JCAR OPS 1.978 & Appendix 1 to JCAR OPS 1.978

1. Terminology
  - 1.1 Line Oriented Evaluation (LOE). LOE is an evaluation methodology used in the ATQP to evaluate trainee performance, and to validate trainee proficiency. LOEs consist of flight simulator scenarios that are developed by the operator in accordance with a methodology approved as part of the ATQP. The LOE should be realistic and include appropriate weather scenarios and in addition should fall within an acceptable range of difficulty. The LOE should include the use of validated event sets to provide the basis for event based assessment. See paragraph 1.4 below.
  - 1.2 Line Oriented Quality Evaluation (LOQE). LOQE is one of the tools used to help evaluate the overall performance of an operation. LOQEs consist of line flights that are observed by appropriately qualified operator personnel to provide feedback to validate the ATQP. The LOQE should be designed to look at those elements of the operation that are unable to be monitored by FDM or Advanced FDM programs.
  - 1.3 Skill based training. Skill based training requires the identification of specific knowledge and skills. The required knowledge and skills are identified within an ATQP as part of a task analysis and are used to provide targeted training.
  - 1.4 Event based Assessment. This is the assessment of flight crew to provide assurance that the required knowledge and skills have been acquired. This is achieved within an LOE. Feedback to the flight crew is an integral part of event based assessment.

## **AC to Appendix 1 to JCAR OPS 1.978(b) (1)** **Requirements, Scope and Documentation of the Program**

See Appendix 1 to JCAR OPS 1.978(b) (1)

1. The documentation should demonstrate how the operator should establish the scope and requirements of the program. The documentation should include:
  - 1.1 How the ATQP should enable the operator to establish an alternative training program that substitutes the requirements as listed in JCAR OPS 1 E and N. The program should demonstrate that the operator is able to improve the training and qualification standards of flight crew to a level that exceeds the standard prescribed in JCAR OPS 1.
  - 1.2 The operator's training needs and established operational and training objectives.
  - 1.3 How the operator defines the process for designing of and gaining approval for the operator's flight crew qualification programs. This should include quantified operational and training objectives identified by the operator's internal monitoring programs. External sources may also be used.
  - 1.4 How the program will:
    - a. Enhance safety;
    - b. Improve training and qualification standards of flight crew;
    - c. Establish attainable training objectives;
    - d. Integrate CRM in all aspects of training;
    - e. Develop a support and feedback process to form a self-correcting training system;
    - f. Institute a system of progressive evaluations of all training to enable consistent and uniform monitoring of the training undertaken by flight crew;
    - g. Enable the operator to be able to respond to the new airplane technologies and changes in the operational environment;
    - h. Foster the use of innovative training methods and technology for flight crew instruction and the evaluation of training systems;
    - i. Make efficient use of training resources, specifically to match the use of training media to the training needs.



## **AC to Appendix 1 to JCAR OPS 1.978(b) (2)**

### **Task Analysis**

See Appendix 1 to JCAR OPS 1.978(b) (2)

1. For each airplane type/class to be included within the ATQP the operator should establish a systematic review that determines and defines the various tasks to be undertaken by the flight crew when operating that type(s)/class. Data from other types/class may also be used. The analysis should determine and describe the knowledge and skills required to complete the various tasks specific to the airplane type/class and/or type of operation. In addition the analysis should identify the appropriate behavioral markers that should be exhibited. The task analysis should be suitably validated in accordance with Appendix 1 to JCAR OPS 1.978(c) (iii). The task analysis, in conjunction with the data gathering program(s) permit the operator to establish a program of targeted training together with the associated training objectives described in AC to Appendix 1 to JCAR OPS 1.978(b) (3) paragraph (c) below.

## **AC to Appendix 1 to JCAR OPS 1.978(b) (3)**

### **Training Program**

See Appendix 1 to JCAR OPS 1.978(b) (3)

1. The training program should have the following structure:
  - 1.1 Curriculum.
  - 1.2 Daily lesson plan.
2. The curriculum should specify the following elements:
  - 2.1 Entry requirements: A list of topics and content, describing what training level will be required before start or continuation of training.
  - 2.2 Topics: A description of what will be trained during the lesson;

## 2.3 Targets/Objectives

- a. Specific target or set of targets that have to be reached and fulfilled before the training course can be continued.
  - b. Each specified target should have an associated objective that is identifiable both by the flight crew and the trainers.
  - c. Each qualification event that is required by the program should specify the training that is required to be undertaken and the required standard to be achieved. (See paragraph 1.4 below)
3. Each lesson/course/training or qualification event should have the same basic structure. The topics related to the lesson have to be listed and the lesson targets should be unambiguous.
  4. Each lesson/course or training event whether classroom, CBT or simulator should specify the required topics with the relevant targets to be achieved.

### **AC to Appendix 1 to JCAR OPS 1.978(b) (4)**

#### **Training Personnel**

See Appendix 1 to JCAR OPS 1.978(b) (4)

1. Personnel who perform training and checking of flight crew in an operator's ATQP should receive the following additional training on:
  - 1.1 ATQP principles and goals;
  - 1.2 Knowledge/skills/behavior as learned from task analysis;
  - 1.3 LOE/ LOFT Scenarios to include triggers / markers / event sets / observable behavior;
  - 1.4 Qualification standards;
  - 1.5 Harmonization of assessment standards;
  - 1.6 Behavioral markers and the systemic assessment of CRM;

- 1.7 Event sets and the corresponding desired knowledge/skills and behavior of the flight crew;
- 1.8 The processes that the operator has implemented to validate the training and qualification standards and the instructors part in the ATQP quality control; and
- 1.9 LOQE.

### **AC to Appendix 1 to JCAR OPS 1.978(b) (5)**

#### **Feedback Loop**

See Appendix 1 to JCAR OPS 1.978(b) (5)

1. The feedback should be used as a tool to validate that the curricula are implemented as specified by the ATQP; this enables substantiation of the curriculum, and that proficiency and training objectives have been met. The feedback loop should include data from operations flight data monitoring, advanced FDM program and LOE/LOQE programs. In addition the evaluation process shall describe whether the overall targets/objectives of training are being achieved and shall prescribe any corrective action that needs to be undertaken.
2. The programs established quality control mechanisms should at least review the following:
  - 2.1 Procedures for approval of recurrent training;
  - 2.2 ATQP instructor training approvals;
  - 2.3 Approval of event set(s) for LOE/LOFT;
  - 2.4 Procedures for conducting LOE and LOQE.

## **AC to Appendix 1 to JCAR OPS 1.978(b) (6) Crew Performance Measurement and Evaluation**

See Appendix 1 to JCAR OPS 1.978(b) (6)

1. The qualification and checking programs should include at least the following elements:
  - 1.1 A specified structure;
  - 1.2 Elements to be tested / examined;
  - 1.3 Targets and/or standards to be attained;
  - 1.4 The specified technical and procedural knowledge and skills, and behavioral markers to be exhibited.
2. An LOE event should comprise of tasks and sub-tasks performed by the crew under a specified set of conditions. Each event has one or more specific training targets/objectives, which require the performance of a specific maneuver, the application of procedures, or the opportunity to practice cognitive, communication or other complex skills. For each event the proficiency that is required to be achieved should be established. Each event should include a range of circumstances under which the crews' performance is to be measured and evaluated. The conditions pertaining to each event should also be established and they may include the prevailing meteorological conditions (ceiling, visibility, wind, turbulence etc.); the operational environment (navigation aid inoperable etc.); and the operational contingencies (non-normal operation etc.).
3. The markers specified under the operator's ATQP should form one of the core elements in determining the required qualification standard. A typical set of markers are shown in the table below:

<b>Event</b>	<b>Marker</b>
Awareness	1 Monitors and reports changes in automation status.
of Airplane Systems	2 Applies closed loop principle in all relevant situations.
	3 Uses all channels for updates
	4 Is aware of remaining technical resources

4. The topics / targets integrated into the curriculum have to be measurable and progression on any training/course is only allowed if the targets are fulfilled.

## **AC to Appendix 1 to JCAR OPS 1.978(b) (9)**

### **Data Monitoring/Analysis Program**

See Appendix 1 to JCAR OPS 1.978(b) (9)

1. The data analysis program should consist of:
  - 1.1 A Flight Data Monitoring (FDM) program: This program should include systematic evaluation of operational data derived from equipment that is able to record the flight profile and relevant operational information during flights conducted by the operator's airplane. Data collection should reach a minimum of 60% of all relevant flights conducted by the operator before ATQP approval is granted. This proportion may be increased at the discretion of CARC.
  - 1.2 An Advanced FDM when an extension to the ATQP is requested: An advanced FDM program is determined by the level of integration with other safety initiatives implemented by the operator, such as the operator's Quality System. The program should include both systematic evaluations of data from an FDM program and flight crew training events for the relevant crews. Data collection should reach a minimum of 80% of all relevant flights and training conducted by the operator. This proportion may be varied at the discretion of CARC.
2. The purpose of either an FDM or advanced FDM program is to enable the operator to:
  - 2.1 Provide data to support the programs implementation and justify any changes to the ATQP;
  - 2.2 Establish operational and training objectives based upon an analysis of the operational environment;
  - 2.3 Monitor the effectiveness of flight crew training and qualification.

3. Data Gathering.

3.1 FDM programs should include a system that captures flight data, and then transforms the data into an appropriate format for analysis. The program should generate information to assist the operations safety personnel in analyzing the data. The analysis should be made available to the ATQP post holder.

3.2 The data gathered should:

- a. Include all fleets that plan to operate under the ATQP;
- b. Include all crews trained and qualified under the ATQP;
- c. Be established during the implementation phase of ATQP; and
- d. Continue throughout the life of the ATQP.

4. Data Handling.

4.1 The operator should establish a process, which ensures the strict adherence to any data handling protocols, agreed with flight crew representative bodies, to ensure the confidentiality of individual flight crew members.

4.2 The data handling protocol should define the maximum period of time that detailed FDM or advanced FDM program data, including exceedences, should be retained. Trend data may be retained permanently.

5. An operator that has an acceptable operations flight data monitoring program prior to the proposed introduction of ATQP may, with the approval of CARC, use relevant data from other fleets not part of the proposed ATQP.

## **AC to Appendix 1 to JCAR OPS 1.978(c) (1) (i)**

### **Safety Case**

See Appendix 1 to JCAR OPS 1.978(c) (1) (i)

1. Safety Case
  - 1.1 A documented body of evidence that provides a demonstrable and valid justification that the program (ATQP) is adequately safe for the given type of operation. The safety case should encompass each phase of implementation of the program and be applicable over the lifetime of the program that is to be overSeen.
  - 1.2 The safety case should:
    - a. Demonstrate the required level of safety;
    - b. Ensure the required safety is maintained throughout the lifetime of the program;
    - c. Minimize risk during all phases of the programs implementation and operation.
2. Elements of a Safety Case:
  - 2.1 Planning: Integrated and planned with the operation (ATQP) that is to be justified;
  - 2.2 Criteria: Develop the applicable criteria - See paragraph 3 below;
  - 2.3 Documentation: Safety related documentation – including a safety checklist;
  - 2.4 Program of implementation: To include controls and validity checks;
  - 2.5 Oversight: Review and audits.

3. Criteria for the establishment of a Safety Case.
  - 3.1 The Safety Case should:
    - a. Be able to demonstrate that the required or equivalent level of safety is maintained throughout all phases of the program, including as required by paragraph (c) below;
    - b. Be valid to the application and the proposed operation (ATQP);
    - c. Be adequately safe and ensure the required regulatory safety standards or approved equivalent safety standards are achieved;
    - d. Be applicable over the entire lifetime of the program;
    - e. Demonstrate Completeness and Credibility of the program;
    - f. Be fully documented;
    - g. Ensure integrity of the operation and the maintenance of the operations and training infra-structure;
    - h. Ensure robustness to system change;
    - i. Address the impact of technological advance, obsolescence and change;
    - j. Address the impact of regulatory change.
4. In accordance with Appendix 1 to JCAR OPS 1.978 paragraph (c) the operator may develop an equivalent method other than that specified above.



## **AMC OPS 1.980**

### **Operation on more than one type or variant**

See JCAR OPS 1.980

#### 1. Terminology

1.1 The terms used in the context of the requirement for operation of more than one type or variant have the following meaning:

- a. Base airplane. An airplane or a group of airplanes, designated by an operator and used as a reference to compare differences with other airplane types/variants within an operator's fleet
- b. Airplane variant. An airplane, or a group of airplanes, with the same characteristics but which have differences from a base airplane which require additional flight crew knowledge, skills, and or abilities that affect flight safety.
- c. Credit. The acceptance of training, checking or recent experience on one type or variant as being valid for another type or variant because of sufficient similarities between the two types or variants.
- d. Differences training. See JCAR OPS 1.950(a) (1).
- e. Familiarization training. See JCAR OPS 1.950(a) (2).
- f. Major change. A change, or changes, within an airplane type or related type, which significantly affect the flight crew interface with the airplane (e.g. flight characteristics, procedures, design/number of propulsion units, change in number of required flight crew).
- g. Minor change. Any change other than a major change.
- h. Operator Difference Requirements (ODRs). A formal description of differences between types or variants flown by a particular operator

## 1.2 Training and checking difference levels

### a. Level A

- i. Training. Level A training can be adequately addressed through self-instruction by a crew member through page revisions, bulletins or differences handouts. Level A introduces a different version of a system or component which the crew member has already shown the ability to use and understand. The differences result in no, or only minor, changes in procedures.
- ii. Checking. A check related to differences is not required at the time of training. However, the crew member is responsible for acquiring the knowledge and may be checked during proficiency checking.

### b. Level B

- i. Training. Level B training can be adequately addressed through aided instruction such as slide/tape presentation, computer based instruction which may be interactive, video or classroom instruction. Such training is typically used for part-task systems requiring knowledge and training with, possibly, partial application of procedures (eg. fuel or hydraulic systems etc.).
- ii. Checking. A written or oral check is required for initial and recurrent differences training.

### c. Level C

- i. Training. Level C training should be accomplished by use of “hands on” FSTDs A qualified according to JCAR FSTD (A) FTD, Level 1 or higher. The differences affect skills, abilities as well as knowledge but do not require the use of “real time” devices. Such training covers both normal and non-normal procedures (for example for flight management systems).

- ii. Checking. An FSTD A used for training level C or higher is used for a check of conversion and recurrent training. The check should utilize a “real time” flight environment such as the demonstration of the use of a flight management system. Maneuvers not related to the specific task do not need to be tested.

d. Level D

- i. Training. Level D training addresses differences that affect knowledge, skills and abilities for which training will be given in a simulated flight environment involving, “real time” flight maneuvers for which the use of an FSTD A qualified according to JCAR FSTD (A) FTD Level 1 would not suffice, but for which motion and visual clues are not required. Such training would typically involve an FSTD (A) as defined in JCAR FSTD (A) FTD Level 2.
- ii. Checking. A proficiency check for each type or variant should be conducted following both initial and recurrent training. However, credit may be given for maneuvers common to each type or variant and need not be repeated. Items trained to level D differences may be checked in FSTDs A qualified according to JCAR FSTD (A) FTD Level 2. Level D checks will therefore comprise at least a full proficiency check on one type or variant and a partial check at this level on the other.

e. Level E

- i. Training. Level E provides a realistic and operationally oriented flight environment achieved only by the use of Level C or D Flight Simulators or the airplane itself. Level E training should be conducted for types and variants which are significantly different from the base airplane and/or for which there are significant differences in handling qualities.

- ii. Checking. A proficiency check on each type or variant should be conducted in a level C or D Flight Simulator or the airplane itself. Either training or checking on each Level E type or variant should be conducted every 6 months. If training and checking are alternated, a check on one type or variant should be followed by training on the other so that a crew member receives at least one check every 6 months and at least one check on each type or variant every 12 months.

**AMC OPS 1.980(b)**

**Methodology - Use of Operator Difference Requirement (ODR) Tables**

See JCAR OPS 1.980(b) & IEM OPS 1.980(b)

- 1. General
  - 1.1 Use of the methodology described below is acceptable to CARC as a means of evaluating airplane differences and similarities to justify the operation of more than one type or variant, and when credit is sought.
- 2. ODR Tables
  - 2.1 Before requiring flight crew members to operate more than one type or variant, operators should first nominate one airplane as the Base Airplane from which to show differences with the second airplane type or variant, the ‘difference airplane’, in terms of technology (systems), procedures, pilot handling and airplane management. These differences, known as Operator Difference Requirements (ODR), preferably presented in tabular format, constitute part of the justification for operating more than one type or variant and also the basis for the associated differences/familiarization training for the flight crew.
- 3. The ODR Tables should be presented as follows:
  - 3.1 Table 1 - ODR 1 – General

Base Airplane: Difference Airplane:				Compliance Method		
GENERAL	DIFFERENCES	FLT CHAR	PROC CHNG	Training	Checking	Recent Experience
General description of Aircraft (dimensions weight, limitations, etc.)	Identification of the relevant differences between the base airplane and the difference airplane.	Impact on flight characteristics (performance and/or handling)	Impact on procedures (Yes or No)	Assessment of the difference levels according to Table 4		

3.2 Table 2 - ODR 2 - systems

<b>Base Airplane: Difference Airplane:</b>				<b>Compliance Method</b>		
SYSTEM	DIFFERENCES	FLT CHAR	PROC CHNG	Training	Checking	Recent Experience
Brief description of systems and subsystems classified according to the ATA 100 index	list of differences for each relevant subsystem between the base airplane and the difference airplane.	Impact on flight characteristics (performance and/or handling)	Impact on procedures (Yes or No)	Assessment of the difference levels according to Table 4		

3.3 Table 3 - ODR 3 - maneuvers

<b>Base Airplane: Difference Airplane:</b>				<b>Compliance Method</b>		
MANEUVERS	DIFFERENCES	FLT CHAR	PROC CHNG	Training	Checking	Recent Experience
Described according to phase of flight (gate, taxi, flight, taxi, gate)	List of relevant differences for each maneuver between the base airplane and the difference airplane.	Impact on flight characteristics (performance and/or handling)	Impact on procedures (Yes or No)	Assessment of the difference levels according to Table 4		

4. Compilation of ODR Tables

4.1 ODR 1 - Airplane general

- a. The general characteristics of the difference airplane should be compared with the base airplane with regard to:
  - i. General dimensions and airplane design;
  - ii. Flight deck general design;
  - iii. Cabin layout;
  - iv. Engines (number, type and position);
  - v. Limitations (flight envelope).

4.2 ODR 2 - Airplane systems

- a. Consideration should be given to differences in design between the difference airplane and the base airplane. This comparison should be completed using the ATA 100 index to establish system and subsystem classification and then an analysis performed for each index item with respect to main architectural, functional and/or operations elements, including controls and indications on the systems control panel.

#### 4.3 ODR 3 - Airplane maneuvers (operational differences)

- a. Operational differences encompass normal, abnormal and emergency situations and include any change in airplane handling and flight management. It is necessary to establish a list of operational items for consideration on which an analysis of differences can be made. The operational analysis should take the following into account:
  - i. Flight deck dimensions (e.g. size, cut-off angle and pilot eye height);
  - ii. Differences in controls (eg. design, shape, location, function);
  - iii. Additional or altered function (flight controls) in normal or abnormal conditions;
  - iv. Procedures;
  - v. Handling qualities (including inertia) in normal and abnormal configurations;
  - vi. Performance in maneuvers;
  - vii. Airplane status following failure;
  - viii. Management (e.g. ECAM, EICAS, nav.aid selection, automatic checklists).

4.4 Once the differences for ODR 1, ODR 2 and ODR 3 have been established, the consequences of differences evaluated in terms of Flight Characteristics (FLT CHAR) and Change of Procedures (PROC CHNG) should be entered into the appropriate columns.

#### 4.5 Difference Levels - crew training, checking and currency

4.5. The final stage of an operator's proposal to operate more than one type or variant is to establish crew training, checking and currency requirements. This may be established by applying the coded difference levels from Table 4 to the Compliance Method column of the ODR Tables.

5. Differences items identified in the ODR systems as impacting flight characteristics, and/or procedures, should be analyzed in the corresponding ATA section of the ODR maneuvers. Normal, abnormal and emergency situations should be addressed accordingly.

6. Table 4 - Difference Levels versus training

<b>Difference Level</b>	<b>Method/Minimum Specification for Training Device</b>
<b>A:</b> Represents knowledge requirement.	Self Instruction through operating bulletins or differences handouts
<b>B:</b> Aided instruction is required to ensure crew understanding, emphasize issues, aid retention of information, or : aided instruction with partial application of procedures	Aided instruction e.g. computer based training (CBT), class room instruction or video tapes. Interactive CBT
<b>C:</b> For variants having part task differences affecting skills or abilities as well as knowledge. Training device required to ensure attainment and retention of crew skills	JCAR FSTD (A) FTD) Level 1
<b>D:</b> Full task differences affecting knowledge, skills and/or abilities using FSTDs A capable of performing flight maneuvers	JCAR FSTD (A) FTD Level 2
<b>E:</b> Full tasks differences requiring high fidelity environment to attain and maintain knowledge skills and abilities.	JCAR FSTD (A) FFS Level C

Note. Levels A and B require familiarization training, levels C, D and E require differences training. For Level E, the nature and extent of the differences may be such that it is not possible to fly both types or variants with a credit in accordance with Appendix 1 to JCAR OPS 1.980, sub-paragraph (d)(7).

## **IEM OPS 1.980(b)**

### **Operation on more than one type or variant - Philosophy and Criteria**

See JCAR OPS 1.980(b)

1. Philosophy
  - 1.1 The concept of operating more than one type or variant depends upon the experience, knowledge and ability of the operator and the flight crew concerned.
  - 1.2 The first consideration is whether or not the two airplane types or variants are sufficiently similar to allow the safe operation of both.
  - 1.3 The second consideration is whether or not the types or variants are sufficiently similar for the training, checking and recent experience items completed on one type or variant to replace those required on the similar type or variant. If these airplanes are similar in these respects, then it is possible to have credit for training, checking and recent experience. Otherwise, all training, checking and recent experience requirements prescribed in Subpart N should be completed for each type or variant within the relevant period without any credit.
2. Differences between airplane types or variants
  - 2.1 The first stage in any operator's submission for crew multi-type or variant operations is to consider the differences between the types or variants. The principal differences are in the following three areas:
    - a. Level of technology. The level of technology of each aircraft type or variant under consideration encompasses at least the following design aspects:
      - i. Flight deck layout (e.g. design philosophy chosen by a manufacturer);
      - ii. Mechanical versus electronic instrumentation;
      - iii. Presence or absence of Flight Management System (FMS);
      - iv. Conventional flight controls (hydraulic, electric or manual controls) versus fly-by-wire;
      - v. Side-stick versus conventional control column;
      - vi. Pitch trim systems;
      - vii. Engine type and technology level (e.g. jet/turboprop/piston, with or without automatic protection systems).



- b. Operational differences. Consideration of operational differences involves mainly the pilot machine interface, and the compatibility of the following:
    - i. Paper checklist versus automated display of checklists or messages (e.g. ECAM, EICAS) during all procedures;
    - ii. Manual versus automatic selection of nav. aids;
    - iii. Navigation equipment;
    - iv. Aircraft weight and performance.
  - c. Handling characteristics. Consideration of handling characteristics includes control response, crew perspective and handling techniques in all stages of operation. This encompasses flight and ground characteristics as well as performance influences (eg. number of engines). The capabilities of the autopilot and auto thrust systems may affect handling characteristics as well as operational procedures.
3. Training, checking and crew management. Alternating training and proficiency checking may be permitted if the submission to operate more than one type or variant shows clearly that there are sufficient similarities in technology, operational procedures and handling characteristics.
4. An example of completed ODR tables for an operator’s proposal for flight crews to operate more than one type or variant may appear as follows:

Table 1 - ODR 1 - Airplane General

Base Airplane: ‘X’ Difference Airplane: ‘Y’				Compliance Method		
GENERAL	DIFFERENCES	FLT CHAR	PROC CHNG	Training	Checking	Recent Experience
Flight Deck	Same flight deck arrangement, 2 observers seats on ‘Y’	NO	NO	A	/	/
Cabin	‘Y’ max certificated Passenger capacity: 335, ‘X’: 179	NO	NO	A	/	/

Table 2 - ODR 2 - Systems

Base Airplane: 'X' Difference Airplane: 'Y'				Compliance Method		
SYSTEMS	DIFFERENCES	FLT CHAR	PROC CHNG	Training	Checking	Recent Experience
21 Air Conditioning	Trim air system	NO	YES	B	B	B
	packs	NO	NO			
	cabin temperature	NO	YES			
22 Auto flight	FMGS architecture	NO	NO	B	B	B
	FMGES functions	NO	YES	C	C	B
	reversion modes	NO	YES	D	D	D
23 Communications						

Table 3 - ODR 3 – Maneuvers

Base Airplane: 'X' Difference Airplane: 'Y'				Compliance Method		
MANEUVERS	DIFFERENCES	FLT CHAR	PROC CHNG	Training	Checking	Recent Experience
Taxi	Pilot eye height, turn radius	YES	NO	D	D	/
	two engine taxi (1&4)	NO	NO	A	/	/
Take-off	Flight Characteristics in ground law	YES	NO	E	E	E
Rejected take-off	Reverser actuation logic	YES	NO	D	D	D
Take-off engine failure	V1/Vr split	YES (P)*	NO	B	B	B
	Pitch attitude/ lateral Control	YES (H)*	NO	E	E	

\*P = Performance, H = Handling

## **IEM OPS 1.985**

### **Training records**

See JCAR OPS 1.985

A summary of training should be maintained by the operator to show a flight crew member's completion of each stage of training and checking.

## **ACJ/AMC/IEM O Cabin Crew**

### **IEM OPS 1.988**

#### **Additional crew members assigned to specialist duties**

See JCAR OPS 1.988

The additional crew members solely assigned to specialist duties to whom the requirements of Subpart O are not applicable include the following:

- i. Child minders/escorts;
- ii. Entertainers;
- iii. Ground engineers;
- iv. Interpreters;
- v. Medical personnel;
- vi. Secretaries; and
- vii. Security staff.

### **IEM OPS 1.990**

#### **Number and Composition of Cabin Crew**

See JCAR OPS 1.990

1. The demonstration or analysis referred to in JCAR OPS 1.990(b)(2) should be that which is the most applicable to the type, or variant of that type, and the seating configuration used by the operator.
2. With reference to JCAR OPS 1.990(b), CARC may require an increased number of cabin crew members in excess of the requirements of JCAR OPS 1.990 on certain types of airplane or operations. Factors which should be taken into account include:
  - a. The number of exits;
  - b. The type of exits and their associated slides;
  - c. The location of exits in relation to cabin crew seats and the cabin layout;

- d. The location of cabin crew seats taking into account cabin crew duties in an emergency evacuation including:
    - i. Opening floor level exits and initiating stair or slide deployment;
    - ii. Assisting passengers to pass through exits; and
    - iii. Directing passengers away from inoperative exits, crowd control and passenger flow management;
  - e. Actions required to be performed by cabin crew in ditching, including the deployment of slide-rafts and the launching of life-rafts.
3. When the number of cabin crew is reduced below the minimum required by JCAR OPS 1.990(b), for example in the event of incapacitation or non-availability of cabin crew, the procedures to be specified in the Operations Manual should result in consideration being given to at least the following:
- a. Reduction of passenger numbers;
  - b. Re-seating of passengers with due regard to exits and other applicable airplane limitations; and
  - c. Relocation of cabin crew and any change of procedures.
4. When scheduling cabin crew for a flight, an operator should establish procedures which take account of the experience of each cabin crew member such that the required cabin crew includes some cabin crew members who have at least 3 months operating experience as a cabin crew member.

### **AMC OPS 1.995(a) (2)**

#### **Minimum requirements**

See JCAR OPS 1.995(a) (2)

1. The initial medical examination or assessment and any re-assessment of cabin crew members should be conducted by, or under the supervision of, a medical practitioner acceptable to CARC.
2. An operator should maintain a medical record for each cabin crew member.

3. The following medical requirements are applicable for each cabin crew member:
  - a. Good health;
  - b. Free from any physical or mental illness which might lead to incapacitation or inability to perform cabin crew duties;
  - c. Normal cardio respiratory function;
  - d. Normal central nervous system;
  - e. Adequate visual acuity 6/9 with or without glasses;
  - f. Adequate hearing; and
  - g. Normal function of ear, nose and throat.

**IEM OPS 1.1000(c)**

**Senior Cabin Crew Training**

See JCAR OPS 1.1000(c)

Training for senior cabin crew members should include:

1. Pre-flight Briefing:
  - a. Operating as a crew;
  - b. Allocation of cabin crew stations and responsibilities; and
  - c. Consideration of the particular flight including:
    - i. Airplane type;
    - ii. Equipment;
    - iii. Area and type of operation including ETOPS; and
    - iv. Categories of passengers, including the disabled, infants and stretcher cases;

2. Co-operation within the crew:
  - a. Discipline, responsibilities and chain of command;
  - b. Importance of co-ordination and communication; and
  - c. Pilot incapacitation;
3. Review of operators' requirements and legal requirements:
  - a. Passengers safety briefing, safety cards;
  - b. Securing of galleys;
  - c. Stowage of cabin baggage;
  - d. Electronic equipment;
  - e. Procedures when fuelling with passengers on board;
  - f. Turbulence; and
  - g. Documentation;
4. Human Factors and Crew Resource Management (Where practicable, this should include the participation of Senior Cabin Crew Members in flight simulator Line Oriented Flying Training exercises);
5. Accident and incident reporting; and
6. Flight and duty time limitations and rest requirements.

## **AC OPS 1.1005/1.1010/1.1015**

### **Crew Resource Management Training**

See JCAR OPS 1.1005 / 1.1010 / 1.1015 & Appendix 2 to JCAR OPS 1.1005 / 1.1010 / 1.1015

1. Introduction
  - 1.1 Crew Resource Management (CRM) should be the effective utilization of all available resources (e.g. crew members, airplane systems, and supporting facilities) to achieve safe and efficient operation.
  - 1.2 The objective of CRM should be to enhance the communication and management skills of the crew member, as well as the importance of effective co-ordination and two-way communication between all crew members.
  - 1.3 CRM training should reflect the culture of the operator, the scale and scope of the operation together with associated operating procedures and areas of operation which produce particular difficulties.
2. General Principles for CRM Training for Cabin Crew
  - 2.1 Cabin crew CRM training should focus on issues related to cabin crew duties, and therefore, should be different from flight crew CRM training. However, the co-ordination of the tasks and functions of flight crew and cabin crew should be addressed.
  - 2.2 Whenever it is practicable to do so, operators should provide combined training for flight crew and cabin crew, including feedback, as appropriate to Appendix 2 to JCAR OPS 1.1005/1.1010/1.1015 Table 1, Columns (d), (e) and (f). This is of particular importance for senior cabin crew members.
  - 2.3 Where appropriate, CRM principles should be integrated into relevant parts of cabin crew training.
  - 2.4 CRM training should include group discussions and the review of accidents and incidents (case based studies).
  - 2.5 Whenever it is practicable to do so, relevant parts of CRM training should form part of the training conducted in cabin mock-ups or aircraft.

- 2.6 CRM training should take into account the items listed in Appendix 2 to JCAR OPS 1.1005/1.1010/1.1015 Table 1. CRM training courses should be conducted in a structured and realistic manner.
- 2.7 The operator should be responsible for the quality of all CRM training, including any training provided by sub-contractors/third parties (in accordance with JCAR OPS 1.035 and AMC OPS 1.035, paragraph 5.1).
- 2.8 CRM training for cabin crew should include an Introductory CRM Course, Operator's CRM Training, and Airplane Type Specific CRM, all of which may be combined.
- 2.9 There should be no assessment of CRM skills. Feedback from instructors or members of the group on individual performance should be given during training to the individuals concerned.
3. Introductory CRM Course
  - 3.1 The Introductory CRM Course should provide cabin crew members with a basic knowledge of Human Factors relevant to the understanding of CRM.
  - 3.2 Cabin crew members from different operators may attend the same Introductory CRM Course provided that operations are similar (See paragraph 1.3).
4. Operator's CRM Training.
  - 4.1 Operator's CRM training should be the application of the knowledge gained in the Introductory CRM Course to enhance communication and co-ordination skills of cabin crew members relevant to the operator's culture and type of operation.
5. Airplane Type Specific CRM
  - 5.1 Airplane Type Specific CRM should be integrated into all appropriate phases of the operator's conversion training on the specific airplane type.
  - 5.2 Airplane Type Specific CRM should be the application of the knowledge gained in previous CRM training on the specifics related to aircraft type, including, narrow/wide bodied airplanes, single/multi deck airplanes, and flight crew and cabin crew composition.



6. Annual Recurrent Training

- 6.1 When a cabin crew member undergoes annual recurrent training, CRM training should be integrated into all appropriate phases of the recurrent training and may include stand-alone modules.
- 6.2 When CRM elements are integrated into all appropriate phases of the recurrent training, the CRM elements should be clearly identified in the training syllabus.
- 6.3 Annual Recurrent CRM Training should include realistic operational situations.
- 6.4 Annual Recurrent CRM Training should include areas as identified by the operator's accident prevention and flight safety program (See JCAR OPS 1.037).

7. CRM Training for Senior Cabin Crew

- 7.1 CRM training for Senior Cabin Crew Members should be the application of knowledge gained in previous CRM training and operational experience relevant to the specific duties and responsibilities of a Senior Cabin Crew Member.
- 7.2 The senior cabin crew member should demonstrate ability to manage the operation and take appropriate leadership/management decisions.

8. CRM Instructor Qualifications

- 8.1 The operator should ensure that all personnel conducting relevant training are suitably qualified to integrate elements of CRM into all appropriate training programs.
- 8.2 A training and standardization program for CRM instructors should be established.

8.3 Cabin crew CRM instructors should:

- a. Have suitable experience of commercial air transport as a cabin crew member; and
- b. Have received instruction on Human Factors Performance Limitations (HPL); and
- c. Have completed an Introductory CRM Course and the Operator's CRM training; and
- d. Have received instructions in training skills in order to conduct CRM courses; and
- e. Be supervised by suitably qualified CRM instructors when conducting their first CRM training course.

8.4 An experienced non-cabin crew CRM instructor may continue to be a cabin crew CRM instructor, provided that the provisions of paragraph 8.3 b) to e) are satisfied and that a satisfactory knowledge has been demonstrated of the nature of the operation and the relevant specific airplane types. In such circumstances, the operator should be satisfied that the instructor has a suitable knowledge of the cabin crew working environment.

8.5 Instructors integrating elements of CRM into conversion, recurrent training, or Senior Cabin Crew Member training, should have acquired relevant knowledge of human factors and have completed appropriate CRM training.

9. Co-ordination between flight crew and cabin crew training departments

9.1 There should be an effective liaison between flight crew and cabin crew training departments. Provision should be made for flight and cabin crew instructors to observe and comment on each other's training. Consideration should be given to creating flight deck scenarios on video for playback to all cabin crew during recurrent training, and to providing the opportunity for cabin crew, particularly senior cabin crew, to participate in Flight Crew LOFT exercises.

## **AMC OPS 1.1012**

### **Familiarization**

See JCAR OPS 1.1012

1. New entrant cabin crew
  - 1.1 Each new entrant cabin crew member having no previous comparable operating experience should:
    - a. Participate in a visit to the airplane to be operated; and
    - b. Participate in familiarization flights as described in paragraph 3 below.
  2. Cabin crew operating on a subsequent airplane type
    - 2.1 A cabin crew member assigned to operate on a subsequent airplane type with the same operator should either:
      - a. Participate in a familiarization flight as described in paragraph 3 below; or
      - b. Participate in an airplane visit to the airplane to be operated.
3. Familiarization Flights
  - 3.1 During familiarization flights, the cabin crew member should be additional to the minimum number of cabin crew required by JCAR OPS 1.990.
  - 3.2 Familiarization flights should be conducted under the supervision of the senior cabin crew member.
  - 3.3 Familiarization flights should be structured and involve the cabin crew member in the participation of safety related pre-flight, in-flight and post-flight duties.
  - 3.4 Familiarizations flights should be operated with the cabin crew member in the operator's uniform.

3.5 Familiarization flights should form part of the training record for each cabin crew member.

4. Airplane visits

4.1 The purpose of airplane visits is to familiarize each cabin crew member with the airplane environment and its equipment. Accordingly, airplane visits should be conducted by suitably qualified persons and in accordance with a syllabus described in the Operations Manual, Part D. The airplane visit should provide an overview of the airplane's exterior, interior and systems including the following:

- a. Interphone and public address systems;
- b. Evacuation alarm systems;
- c. Emergency lighting;
- d. Smoke detection systems;
- e. Safety/emergency equipment;
- f. Flight deck;
- g. Cabin crew stations;
- h. Toilet compartments;
- i. Galleys, galley security and water shut-off;
- j. Cargo areas if accessible from the passenger compartment during flight;
- k. Circuit breaker panels located in the passenger compartment;
- l. Crew rest areas;
- m. Exit location and its environment.

4.2 An airplane familiarization visit may be combined with the conversion training required by JCAR OPS 1.1010(c) (3).

## **AC OPS 1.1005/1.1010/1.1015/1.1020**

### **Representative Training Devices**

See JCAR OPS 1.1005/1.1010/1.1015/1.1020

1. A representative training device may be used for the training of cabin crew as an alternative to the use of the actual airplane or required equipment.
2. Only those items relevant to the training and testing intended to be given should accurately represent the airplane in the following particulars:
  - a. Layout of the cabin in relation to exits, galley areas and safety equipment stowage;
  - b. Type and location of passenger and cabin crew seats;
  - c. Exits in all modes of operation (particularly in relation to method of operation, their mass and balance and operating forces) including failure of power assist systems where fitted; and
  - d. Safety equipment of the type provided in the airplane (such equipment may be 'training use only' items and, for oxygen and protective breathing equipment, units charged with or without oxygen may be used).
3. When determining whether an exit can be considered to be a variant of another type, the following factors should be assessed:
  - a. Exit arming/disarming;
  - b. Direction of movement of the operating handle;
  - c. Direction of exit opening;
  - d. Power assists mechanisms;
  - e. Assist means, e.g. evacuation slides]

## **IEM OPS 1.1015**

### **Recurrent training**

See JCAR OPS 1.1015

Operators should ensure that a formalized course of recurrent training is provided for cabin crew in order to ensure continued proficiency with all equipment relevant to the airplane types that they operate.

## **AMC OPS 1.1020**

### **Refresher Training**

See JCAR OPS 1.1020

In developing the content of any refresher training program prescribed in JCAR OPS 1.1020, operators should consider (in consultation with the CARC) whether, for airplanes with complex equipment or procedures, refresher training may be necessary for periods of absence that are less than the 6 months prescribed in JCAR OPS 1.1020(a).

## **IEM OPS 1.1020(a)**

### **Refresher training**

See JCAR OPS 1.1020(a) & AMC OPS 1.1020

An operator may substitute recurrent training for refresher training if the re-instatement of the cabin crew member's flying duties commences within the period of validity of the last recurrent training and checking. If the period of validity of the last recurrent training and checking has expired, conversion training is required.

## **AMC OPS 1.1025**

### **Checking**

See JCAR OPS 1.1025

1. Elements of training which require individual practical participation should be combined with practical checks.
2. The checks required by JCAR OPS 1.1025 should be accomplished by the method appropriate to the type of training including:
  - a. Practical demonstration; and/or
  - b. Computer based assessment; and/or
  - c. In-flight checks; and/or
  - d. Oral or written tests.

## **AC OPS 1.1030**

### **Operation on more than one type or variant**

See JCAR OPS 1.1030

1. For the purposes of JCAR OPS 1.1030(b) (1), when determining similarity of exit operation the following factors should be assessed to justify the finding of similarity:
  - a. Exit arming/disarming;
  - b. Direction of movement of the operating handle;
  - c. Direction of exit opening;
  - d. Power assists mechanisms;
  - e. Assist means, e.g. evacuation slides. Self-help exits, for example Type III and Type IV exits, need not be included in this assessment.
  
2. For the purposes of JCAR OPS 1.1030(a) (2) and (b) (2), when determining similarity of location and type of portable safety equipment the following factors should be assessed to justify the finding of similarity:
  - a. All portable safety equipment is stowed in the same, or in exceptional circumstances, in substantially the same location;
  - b. All portable safety equipment requires the same method of operation;
  - c. Portable safety equipment includes:
    - i. Fire fighting equipment;
    - ii. Protective Breathing Equipment (PBE);
    - iii. Oxygen equipment;
    - iv. Crew lifejackets;
    - v. Torches;
    - vi. Megaphones;
    - vii. First aid equipment;
    - viii. Survival equipment and signaling equipment;
    - ix. Other safety equipment where applicable.

- 3 For the purposes of sub-paragraph of JCAR OPS 1.1030(a) (2) and (b) (3), type specific emergency procedures include, but are not limited, to the following:
  - a. Land and water evacuation;
  - b. In-flight fire;
  - c. Decompression;
  - d. Pilot incapacitation.
  
- 4 When changing airplane type or variant during a series of flights, the cabin crew safety briefing required by AMC OPS 1.210(a) should include a representative sample of type specific normal and emergency procedures and safety equipment applicable to the actual airplane type to be operated.

### **IEM OPS 1.1035**

#### **Training records**

See JCAR OPS 1.1035

An operator should maintain a summary of training to show a trainee's completion of every stage of training and checking.

### **IEM to Appendix 1 to JCAR OPS 1.1005/1.1010/1.1015/1.1020**

#### **Crowd Control**

See Appendix 1 to JCAR OPS 1.1005/1.1010/1.1015/1.1020

1. Crowd control
  - 1.1 Operators should provide training in the application of crowd control in various emergency situations. This training should include:
    - a. Communications between flight crew and cabin crew and use of all communications equipment, including the difficulties of co-ordination in a smoke-filled environment;
    - b. Verbal commands;



- c. The physical contact that may be needed to encourage people out of an exit and onto a slide;
- d. The re-direction of passengers away from unusable exits;
- e. The marshalling of passengers away from the airplane;
- f. The evacuation of disabled passengers; and
- g. Authority and leadership.

### **IEM to Appendix 1 to JCAR OPS 1.1005/1.1010/1.1015/1.1020**

#### **Training Methods**

See Appendix 1 to JCAR OPS 1.1005/1.1010/1.1015/1.1020

Training may include the use of mock-up facilities, video presentations; computer based training and other types of training. A reasonable balance between the different training methods should be achieved.

### **IEM to Appendix 1 to JCAR OPS 1.1010/1.1015**

#### **Conversion and recurrent training**

See Appendix 1 to JCAR OPS 1.1010/1.1015

1. A review should be carried out of previous initial training given in accordance with JCAR OPS 1.1005 in order to confirm that no item has been omitted. This is especially important for cabin crew members first transferring to airplanes fitted with life-rafts or other similar equipment.
2. Fire and smoke training requirements

<b>Training requirement/interval</b>	<b>Required activity</b>		
First conversion to airplane type (e.g. new entrant)	Actual fire fighting and handling equipment		(Note 1)
Every year during recurrent training		Handling equipment	
Every 3 years during recurrent training	Actual fire fighting and handling equipment		(Note 1)
Subsequent a/c conversion	(Note 1)	(Note 1)	(Notes 2 & 3)
New firefighting equipment		Handling equipment	

#### **NOTES:**

1. Actual fire fighting during training must include use of at least one fire extinguisher and extinguishing agent as used on the airplane type. An alternative extinguishing agent may be used in place of Halon.

2. Fire fighting equipment is required to be handled if it is different to that previously used.
3. Where the equipment between airplanes types is the same, training is not required if within the validity of the 3 year check.

## **AMC/IEM P Manuals, Logs & Records**

### **IEM OPS 1.1040(b)**

#### **Elements of the Operations Manual subject to approval**

See JCAR OPS 1.1040(b)

1. A number of the provisions of JCAR OPS require the prior approval of CARC. As a consequence, the related sections of the Operations Manual should be subject to special attention. In practice, there are two possible options:
  - a. CARC approves a specific item (e.g. with a written response to an application) which is then included in the Operations Manual. In such cases, CARC merely checks that the Operations Manual accurately reflects the content of the approval. In other words, such text has to be acceptable to CARC; or
  - b. An operator's application for an approval includes the related, proposed, Operations Manual text in which case, CARC written approval encompasses approval of the text.
2. In either case, it is not intended that a single item should be subject to two separate approvals.
3. The following list indicates only those elements of the Operations Manual which require specific approval by CARC. (A full list of every approval required by JCAR OPS 1 in its entirety may be found in operations manual compliance list)

<b>Ops Manual Section (App. 1 to JCAR OPS 1.1045)</b>	<b>Subject</b>	<b>JCAR OPS Reference</b>
A 2.4	Operational Control	1.195
A 5.2(f)	Procedures for flight crew to operate on more than 1 type or variant	1.980
A 5.3(c)	Procedures for cabin crew to operate on four airplane types	1.1030(a)
A 8.1.1	Method of determination of minimum flight attitudes	1.250(b)
A 8.1.4	En-route single engine safe forced landing area for land planes	1.542(a)
A 8.1.8 Mass & balance:	(i) Standard mass values other than those specified in Subpart J	1.620(g)
	(ii) Alternative documentation and related procedures	1.625(c)
	(iii) Omission of data from documentation	App. 1, 1.625, § (a)(1)(ii)
	(iv) Special standard masses for the traffic load	App. 1, 1.605, § (b)
A 8.1.11	Tech Log	1.915(b)
A 8.4	Cat II/III Operations	1.440(a)(3), (b) & App. 1 to JCAR OPS 1.455, Note
A 8.5	ETOPS Approval	1.246
A 8.6	Use of MEL	1.030(a)
A 9	Dangerous Goods	1.1155
A 8.3.2(b)	MNPS	1.243
A 8.3.2(c)	RNAV (RNP)	1.243
A 8.3.2(f)	RVSM	1.241
B 1.1(b)	Max. approved passenger seating configuration	1.480(a)(6)
B 2(g)	Alternate method for verifying approach mass (DH < 200ft) - Performance Class A	1.510(b)
B 4.1(h)	Steep Approach Procedures and Short Landing Operations - Performance Class B	1.515(a)(3) & (a)(4) & 1.550(a)
B 6(b)	Use of on-board mass and balance systems	App. 1 to JCAR OPS 1.625, § (c)
B 9	MEL	1.030(a)
D 2.1	Cat II/III Training syllabus flight crew	1.450(a)(2)
	Recurrent training program flight crew	1.965(a)(2)
	Advanced qualification, program	1.978(a)
D 2.2	Initial training cabin crew	1.1005
	Recurrent training program cabin crew	1.1015(b)
D 2.3(a)	Dangerous Goods	1.1220(a)

## **IEM OPS 1.1040(c)**

### **Operations Manual - Language**

See JCAR OPS 1.1040(c)

1. JCAR OPS 1.1040(c) requires the Operations Manual to be prepared in the English language.

## **AMC OPS 1.1045**

### **Operations Manual Contents**

See JCAR OPS 1.1045

1. Appendix 1 to JCAR OPS 1.1045 prescribes in detail the operational policies, instructions, procedures and other information to be contained in the Operations Manual in order that operations personnel can satisfactorily perform their duties. When compiling an Operations Manual, an operator may take advantage of the contents of other relevant documents. Material produced by the operator for Part B of the Operations Manual may be supplemented with or substituted by applicable parts of the Airplane Flight Manual required by JCAR OPS 1.1050 or, where such a document exists, by an Airplane Operating Manual produced by the manufacturer of the airplane. In the case of performance class B airplanes. It is acceptable that a “Pilot Operating Handbook” (POH) or equivalent document is used as Part B of the Operations Manual, provided that the POH covers the necessary items. For Part C of the Operations Manual, material produced by the operator may be supplemented with or substituted by applicable Route Guide material produced by a specialized professional company.
2. If an operator chooses to use material from another source in his Operations Manual he should either copy the applicable material and include it directly in the relevant part of the Operations Manual, or the Operations Manual should contain a statement to the effect that a specific manual(s) (or parts thereof) may be used instead of the specified part(s) of the Operations Manual.
3. If an operator chooses to make use of material from an alternative source (e.g. a Route Manual producer, an airplane manufacturer or a training organization) as explained above, this does not absolve the operator from the responsibility of verifying the applicability and suitability of this material (See JCAR OPS 1.1040(k)). Any material received from an external source should be given its status by a statement in the Operations Manual.

## **IEM OPS 1.1045(c)**

### **Operations Manual Structure**

See JCAR OPS 1.1045(c) & Appendix 1 to JCAR OPS 1.1045

1. JCAR OPS 1.1045(a) prescribes the main structure of the Operations Manual as follows:
  - Part A – General/Basic;
  - Part B – Airplane Operating Matters – Type related;
  - Part C – Route and Aerodrome Instructions and Information;
  - Part D – Training
2. JCAR OPS 1.1045 (c) requires the operator to ensure that the detailed structure of the Operations Manual is acceptable to CARC.
3. Appendix 1 to JCAR OPS 1.1045 contains a comprehensively detailed and structured list of all items to be covered in the Operations Manual. Since it is believed that a high degree of standardization of Operations Manuals within the JCARs operators will lead to improved overall flight safety, it is strongly recommended that the structure described in this IEM should be used by operators as far as possible. A List of Contents based upon Appendix 1 to JCAR OPS 1.1045 is given below.
4. Manuals which do not comply with the recommended structure may require a longer time to be accepted / approved by CARC.
5. To facilitate comparability and usability of Operations Manuals by new personnel, formerly employed by another operator, operators are recommended not to deviate from the numbering system used in Appendix 1 to JCAR OPS 1.1045. If there are sections which, because of the nature of the operation, do not apply, it is recommended that operators maintain the numbering system described below and insert ‘Not applicable’ or ‘Intentionally blank’ where appropriate.

## **Operations Manual Structure (List of Contents)**

### **Part A GENERAL/BASIC**

#### **0 ADMINISTRATIONS AND CONTROL OF OPERATIONS MANUAL**

- 0.1 Introduction
- 0.2 System of amendment and revision

#### **1. ORGANIZATION AND RESPONSIBILITIES**

- 1.1 Organizational structure
- 1.2 Names of nominated post holders
- 1.3 Responsibilities and duties of operations management personnel
- 1.4 Authority, duties and responsibilities of the commander
- 1.5. Duties and responsibilities of crew members other than the commander

#### **2. OPERATIONAL CONTROL AND SUPERVISION**

- 2.1 Supervision of the operation by the operator
- 2.2 System of promulgation of additional operational instructions and information
- 2.3 Accident prevention and flight safety program
- 2.4 Operational control
- 2.5 Powers of Authority

#### **3. QUALITY SYSTEM**

#### **4. CREW COMPOSITION**

- 4.1 Crew Composition
- 4.2 Designation of the commander
- 4.3 Flight crew incapacitation
- 4.4 Operation on more than one type

#### **5. QUALIFICATION REQUIREMENTS**

- 5.1 Description of license, qualification/competency, training, checking requirements etc.
- 5.2 Flight crew
- 5.3 Cabin crew
- 5.4 Training, checking and supervisory personnel
- 5.5 Other operations personnel

**6. CREW HEALTH PRECAUTIONS**

6.1 Crew health precautions

**7. FLIGHT TIME LIMITATIONS**

7.1 Flight and Duty Time limitations and Rest requirements

7.2 Exceedances of flight and duty time limitations and/or reduction of rest periods

**8. OPERATING PROCEDURES**

8.1 Flight Preparation Instructions

8.1.1 Minimum Flight Altitudes

8.1.2 Criteria for determining the usability of aerodromes

8.1.3 Methods for the determination of Aerodrome Operating Minima

8.1.4 En-route Operating Minima for VFR flights or VFR portions of a flight

8.1.5 Presentation and Application of Aerodrome and En Route Operating Minima

8.1.6 Interpretation of meteorological information

8.1.7 Determination of the quantities of fuel, oil and water methanol carried

8.1.8 Mass and Centre of Gravity

8.1.9 ATS Flight Plan

8.1.10 Operational Flight Plan

8.1.11 Operator's Airplane Technical Log

8.1.12 List of documents, forms and additional information to be carried

8.2 Ground Handling Instructions

8.2.1 Fuelling procedures

8.2.2 Airplane, passengers and cargo handling procedures related to safety

8.2.3 Procedures for the refusal of embarkation

8.2.4 De-icing and Anti-icing on the Ground



8.3 Flight Procedures

8.3.1 VFR/IFR policy

8.3.2 Navigation Procedures

8.3.3 Altimeter setting procedures

8.3.4 Altitude alerting system procedures

8.3.5 Ground Proximity Warning System procedures

8.3.6 Policy and procedures for the use of TCAS/ACAS

8.3.7 Policy and procedures for in-flight fuel management

8.3.8 Adverse and potentially hazardous atmospheric conditions

8.3.9 Wake Turbulence

8.3.10 Crew members at their stations

8.3.11 Use of safety belts for crew and passengers

8.3.12 Admission to Flight Deck

8.3.13 Use of vacant crew seats

8.3.14 Incapacitation of crew members

8.3.15 Cabin Safety Requirements

8.3.16 Passenger briefing procedures

8.3.17 Procedures for airplanes operated whenever required cosmic or solar radiation detection equipment is carried

8.4 All Weather Operations

8.5 ETOPS

8.6 Use of the Minimum Equipment and Configuration Deviation List(s)

8.7 Non revenue flights

8.8 Oxygen Requirements

**9. DANGEROUS GOODS AND WEAPONS**

**10. SECURITY**

**11. HANDLING OF ACCIDENTS AND OCCURRENCES**

**12. RULES OF THE AIR**

**13. LEASING**

## **Part B AIRPLANE OPERATING MATTERS TYPE RELATED**

- 0 GENERAL INFORMATION AND UNITS OF MEASUREMENT**
- 1. LIMITATIONS**
- 2. NORMAL PROCEDURES**
- 3. ABNORMAL AND EMERGENCY PROCEDURES**
- 4. PERFORMANCE**
  - 4.1 Performance data
  - 4.2 Additional performance data
- 5. FLIGHT PLANNING**
- 6. MASS AND BALANCE**
- 7. LOADING**
- 8. CONFIGURATION DEVIATION LIST**
- 9. MINIMUM EQUIPMENT LIST**
- 10. SURVIVAL AND EMERGENCY EQUIPMENT INCLUDING OXYGEN**
- 11. EMERGENCY EVACUATION PROCEDURES**
  - 11.1 Instructions for preparation for emergency evacuation
  - 11.2 Emergency evacuation procedures
- 12. AIRPLANE SYSTEMS**

**Part C ROUTE AND AERODROME INSTRUCTIONS AND INFORMATION**

## **Part D TRAINING**

- 1. TRAINING SYLLABI AND CHECKING PROGRAMS – GENERAL**
- 2. TRAINING SYLLABI AND CHECKING**
  - 2.1 Flight Crew
  - 2.2 Cabin Crew
  - 2.3 Operations Personnel including Crew Members
  - 2.4. Operations Personnel other than Crew Members
- 3. PROCEDURES**
  - 3.1 Procedures for training and checking
  - 3.2 Procedures to be applied in the event that personnel do not achieve or maintain required standards
  - 3.3 Procedures to ensure that abnormal or emergency situations are not simulated during commercial air transportation flights
- 4. DOCUMENTATION AND STORAGE**

## **IEM OPS 1.1055(a) (12)**

### **Signature or equivalent**

See JCAR OPS 1.1055(a) (12)

1. JCAR OPS 1.1055 requires a signature or its equivalent. This IEM gives an example of how this can be arranged where normal signature by hand is impracticable and it is desirable to arrange the equivalent verification by electronic means.
2. The following conditions should be applied in order to make an electronic signature the equivalent of a conventional hand-written signature:
  - i. Electronic 'signing' should be achieved by entering a Personal Identification Number (PIN) code with appropriate security etc.
  - ii. Entering the PIN code should generate a print-out of the individual's name and professional capacity on the relevant document(s) in such a way that it is evident, to anyone having a need for that information, who has signed the document;
  - iii. The computer system should log information to indicate when and where each PIN code has been entered;
  - iv. The use of the PIN code is, from a legal and responsibility point of view, considered to be fully equivalent to signature by hand;
  - v. The requirements for record keeping remain unchanged; and.
  - vi. All personnel concerned should be made aware of the conditions associated with electronic signature and should confirm this in writing.

## **IEM OPS 1.1055(b)**

### **Journey log**

See JCAR OPS 1.1055(b)

The ‘other documentation’ referred to in this paragraph might include such items as the operational flight plan, the airplane technical log, flight report, crew lists etc

## **IEM to Appendix 1 to JCAR OPS 1.1045**

### **Operations Manual Contents**

1. With reference to Operations Manual Section A, paragraph 8.3.17, on cosmic radiation, limit values should be published in the Operations Manual only after the results of scientific research are available and internationally accepted.
2. With reference to Operations Manual Section B, paragraph 9 (Minimum Equipment List) and 12 (Airplane Systems) operators should give consideration to using the ATA number system when allocating chapters and numbers for airplane systems.

## **ACJ/AMC/IEM R**

### **Transport of Dangerous Goods by Air**

#### **AC OPS (IEM) 1.1150(a) (5) & (a) (6)**

##### **Terminology - Dangerous Goods Accident and Dangerous Goods Incident**

See JCAR OPS 1.1150(a) (5) & (a) (6)

As a dangerous goods accident (See JCAR OPS 1.1150(a) (5)) and dangerous goods incident (See JCAR OPS 1.1150(a) (6)) may also constitute an aircraft accident, serious incident or incident the criteria for the reporting both types of occurrence should be satisfied.

#### **AC OPS 1.1160(a)**

##### **Medical Aid for a Patient**

See JCAR OPS 1.1160(a)

1. Gas cylinders, medications, other medical material (such as sterilizing wipes) and wet cell or lithium batteries are the dangerous goods which are normally provided for use in flight as medical aid for a patient. However, what is carried may depend on the needs of the patient. These dangerous goods are not those which are a part of the normal equipment of the airplane.

#### **AC OPS (IEM) 1.1160(b)**

##### **Dangerous goods on an airplane in accordance with the relevant regulations or for operating reasons**

See JCAR OPS 1.1160(b)

1. Dangerous goods required to be on board an airplane in accordance with the relevant JCARs or for operating reasons are those which are for:
  - a. The airworthiness of the airplane;
  - b. The safe operation of the airplane; or
  - c. The health of passengers or crew.

2. Such dangerous goods include but are not limited to:
  - a. Batteries;
  - b. Fire extinguishers;
  - c. First-aid kits;
  - d. Insecticides/Air fresheners;
  - e. Life saving appliances; and
  - f. Portable oxygen supplies.

**AC OPS (IEM) 1.1160(c) (1)**

**Scope – Dangerous goods carried by passengers or crew**

See JCAR OPS 1.1160(c) (1)

1. The Technical Instructions exclude some dangerous goods from the requirements normally applicable to them when they are carried by passengers or crew members, subject to certain conditions.
2. For the convenience of operators who may not be familiar with the Technical Instructions, these requirements are repeated below.
3. The dangerous goods which each passenger or crew member can carry are:
  - a. Alcoholic beverages containing more than 24% but not exceeding 70% alcohol by volume, when in retail packaging's not exceeding 5 liters and with a total not exceeding 5 liters per person;
  - b. Non-radioactive medicinal or toilet articles (including aerosols, hair sprays, perfumes, medicines containing alcohol); and, in checked baggage only, aerosols which are non-flammable, non-toxic and without subsidiary risk, when for sporting or home use. Release valves on aerosols must be protected by a cap or other suitable means to prevent inadvertent release. The net quantity of each single article should not exceed 0.5 liter or 0.5 kg and the total net quantity of all articles should not exceed 2 liters or 2 kg;



- c. Safety matches or a lighter for the person's own use and when carried on the person. 'Strike anywhere' matches, lighters containing unabsorbed liquid fuel (other than liquefied gas), lighter fuel and lighter refills are not permitted;
- d. A hydrocarbon gas-powered hair curler, providing the safety cover is securely fitted over the heating element. Gas refills are not permitted;
- e. Small cylinders of a gas of division 2.2 worn for the operation of mechanical limbs and spare cylinders of a similar size if required to ensure an adequate supply for the duration of the journey;
- f. Radio isotopic cardiac pacemakers or other devices (including those powered by lithium batteries) implanted in a person, or radio-pharmaceuticals contained within the body of a person as a result of medical treatment;
- g. A small medical or clinical thermometer containing mercury, for the person's own use, when in its protective case;
- h. Dry ice, when used to preserve perishable items, providing the quantity of dry ice does not exceed 2 kg and the package permits the release of the gas. Carriage may be in carry-on (cabin) or checked baggage, but when in checked baggage the operator's agreement is required;
- i. When carriage is allowed by the operator, small gaseous oxygen or air cylinders for medical use;
- j. When carriage is allowed by the operator, not more than two small cylinders of carbon dioxide [or another suitable gas of division 2.2 fitted into a self-inflating life-jacket and not more than two spare cylinders;
- k. When carriage is allowed by the operator, wheelchairs or other battery-powered mobility aids with non-spill able batteries, providing the equipment is carried as checked baggage. The battery should be securely attached to the equipment, be disconnected and the terminals insulated to prevent accidental short circuits;

1. When carriage is allowed by the operator, wheelchairs or other battery-powered mobility aids with spill able batteries, providing the equipment is carried as checked baggage. When the equipment can be loaded, stowed, secured and unloaded always in an upright position, the battery should be securely attached to the equipment, be disconnected and the terminals insulated to prevent accidental short circuits. When the equipment cannot be kept upright, the battery should be removed and carried in a strong, rigid packaging, which should be leak-tight and impervious to battery fluid. The battery in the packaging should be protected against accidental short circuits, be held upright and be surrounded by absorbent material in sufficient quantity to absorb the total liquid contents. The package containing the battery should have on it 'Battery wet, with wheelchair' or 'Battery wet, with mobility aid', bear a 'Corrosives' label and be marked to indicate its correct orientation. The package should be protected from upset by securement in the cargo compartment of the airplane. The commander should be informed of the location of a wheelchair or mobility aid with an installed battery or of a packed battery;
  
- m. When carriage is allowed by the operator, cartridges for weapons, (UN0012 and UN0014 only) in division 1.4S, providing they are for that person's own use, they are securely boxed and in quantities not exceeding 5 kg gross mass and they are in checked baggage. Cartridges with explosive or incendiary projectiles are not permitted. Allowances for more than one person must not be combined into one or more packages;

Note: Division 1.4S is a classification assigned to an explosive. It refers to cartridges which are packed or designed so that any dangerous effects from the accidental functioning of one or more cartridges in a package are confined within the package unless it has been degraded by fire, when the dangerous effects are limited to the extent that they do not hinder fire fighting or other emergency response efforts in the immediate vicinity of the package. Cartridges for sporting use are likely to be within Division 1.4S.

- n. When carriage is allowed by the operator, a mercurial barometer or mercurial thermometer in carry-on (cabin) baggage when in the possession of a representative of a government weather bureau or similar official agency. The barometer or thermometer should be packed in a strong packaging having inside a sealed inner liner or bag of strong leak-proof and puncture resistant material impervious to mercury closed in such a way as to prevent the escape of mercury from the package irrespective of its position. The commander should be informed when such a barometer or thermometer is to be carried;
- o. When carriage is allowed by the operator, heat producing articles (i.e. battery operated equipment, such as under-water torches and soldering equipment, which if accidentally activated will generate extreme heat which can cause a fire), providing the articles are in carry-on (cabin) baggage. The heat producing component or energy source should be removed to prevent accidental functioning;
- p. With the approval of the operator(s), one avalanche rescue backpack per person equipped with a pyrotechnic trigger mechanism containing not more than 200 mg net of division 1.4S and not more than 250 mg of compressed gas in division 2.2. The backpack must be packed in such a manner that it cannot be accidentally activated. The airbags within the backpack must be fitted with pressure relief valves;
- q. Consumer electronic devices (watches, calculating machines, cameras, cell phones, lap top computers, camcorders, etc.) containing lithium or lithium ion cells or batteries when carried by passengers or crew for personal use. Spare batteries must be individually protected so as to prevent short circuits and carried in carryon baggage only. In addition, each spare battery must not exceed the following quantities:
- For lithium metal or lithium alloy batteries, lithium content of not more than 2 grams; or for lithium batteries, an aggregate equivalent lithium content of not more than 8 grams.
  - Lithium ion batteries with an aggregate equivalent lithium content of more than 8 grams but not more than 25 grams may be carried in carryon baggage if they are individually protected so as to prevent short circuits and are limited to two spare batteries per person.

4. The list in the Technical Instructions of items permitted for carriage by passengers or crew may be revised periodically and JCAR OPS may not always reflect the current list. Consequently the latest version of the Technical Instructions should also be consulted.

### **AC OPS (IEM) 1.1165(b)**

#### **Exemption and approval procedures of the Technical Instructions**

See JCAR OPS 1.1165(b)

1. The Technical Instructions provide that in certain circumstances dangerous goods, which are normally forbidden on an airplane, may be carried. These circumstances include cases of extreme urgency or when other forms of transport are inappropriate or when full compliance with the prescribed requirements is contrary to the public interest. In these circumstances all the States concerned may grant exemptions from the provisions of the Technical Instructions provided that every effort is made to achieve an overall level of safety which is equivalent to that provided by the Technical Instructions. Although exemptions are most likely to be granted for the carriage of dangerous goods which are not permitted in normal circumstances, they may also be granted in other circumstances, such as when the packaging to be used is not provided for by the appropriate packing method or the quantity in the packaging is greater than that permitted. The Instructions also make provision for some dangerous goods to be carried when an approval has been granted only by the State of Origin, providing specific conditions, which are laid down in the Technical Instructions, are met.
2. The States concerned are those of origin, transit, over flight and destination of the consignment and that of the operator. However, the Technical Instructions allow for the State of over flight to consider an application for exemption based solely on whether an equivalent level of safety has been achieved, if none of the other criteria for granting an exemption are relevant.
3. The Technical Instructions provide that exemptions and approvals are granted by the "appropriate national authority", which is intended to be the authority responsible for the particular aspect against which the exemption or approval is being sought. The Instructions do not specify who should Seek exemptions and, depending on the legislation of the particular State, this may mean the operator, the shipper or an agent. If an exemption or approval has been granted to other than an operator, the operator should ensure a copy has been obtained before the relevant flight. The operator should ensure all relevant conditions on an exemption or approval are met.

4. The exemption or approval referred to in JCAR OPS 1.1165(b) is in addition to the approval required by JCAR OPS 1.1155.

### **AC OPS 1.1215(c) (1)**

#### **Information to the Commander**

See JCAR OPS 1.1215(c) (1)

If the volume of information provided to the commander is such that it would be impracticable to transmit it in the event of an in-flight emergency, a summary of the information should be provided to the commander by the operator, containing at least the quantities and class or division of the dangerous goods in each cargo compartment.

### **AC OPS (AMC) 1.1215(e)**

#### **Information in the Event of an In-flight Emergency**

See JCAR OPS 1.1215(e)

1. To assist the ground services in preparing for the landing of an airplane in an emergency situation, it is essential that adequate and accurate information about any dangerous goods carried on board as cargo be given to the appropriate air traffic services unit. Wherever possible this information should include the proper shipping name and/or the UN/ID number, the class/division and for Class 1 the compatibility group, any identified subsidiary risks(s), the quantity and the location on board the airplane.
2. When it is not possible to include all the information, those parts thought most relevant in the circumstances should be given, such as the UN/ID numbers or classes/divisions and quantity or a summary of the quantities and class/division in each cargo compartment. As an alternative, a telephone number can be given from where a copy of the written information to the commander can be obtained during the flight.
3. It is accepted that due to the nature of the in-flight emergency, the situation may never permit the commander to inform the appropriate air traffic services unit of the dangerous goods carried as cargo on board the airplane.

## **AC (AMC) OPS 1.1220**

### **Training**

See JCAR OPS 1.1220

1. Application for Approval of Training Programs Applications for approval of training programs should indicate how the training will be carried out. Training intended to give general information and guidance may be by any means including handouts, leaflets, circulars, slide presentations, videos, etc, and may take place on-the-job or off-the-job. Training intended to give an in-depth and detailed appreciation of the whole subject or particular aspects of it should be by formal training courses, which should include a written examination, the successful passing of which will result in the issue of the proof of qualification. Applications for formal training courses should include the course objectives, the training program syllabus/curricula and examples of the written examination to be undertaken.
2. Instructors. Instructors should have knowledge not only of training techniques but also of the transport of dangerous goods by air, in order that the subject be covered fully and questions adequately answered.
3. Aspects of training. The aspects of training specified in the Technical Instructions are applicable whether the training is for general information and guidance or to give an in-depth and detailed appreciation. The extent to which any aspect of training should be covered is dependent upon whether it is for general information or to give in-depth appreciation. Additional aspects not identified in the Technical Instructions may need to be covered, or some aspects omitted, depending on the responsibilities of the individual.
4. Levels of Training
  - a. Where it is intended to give an in-depth and a detailed appreciation of the whole subject or of the area(s) being covered, such that the person being trained gains in knowledge so as to be able to apply the detailed requirements of the Technical Instructions. This training should include establishing, by means of a written examination covering all the areas of the training program, that a required minimum level of knowledge has been acquired; or

- b. Where it is intended to give general information and guidance about the area(s) being covered, such that the person being trained receives an overall awareness of the subject. This training should include establishing by means of a written or oral examination covering all areas of the training program, that a required minimum level of knowledge has been acquired.

## 5. How to Achieve Training

- 5.1 Training providing general information and guidance is intended to give a general appreciation of the requirements for the transport by air of dangerous goods. It may be achieved by means of handouts, leaflets, circulars, slide presentations, videos, etc, or a mixture of several of these means. The training does not need to be given by a formal training course and may take place 'on-the-job' or 'off-the-job'.
- 5.2 Training providing in-depth guidance and a detailed appreciation of the whole subject or particular areas of it is intended to give a level of knowledge necessary for the application of the requirements for the transport by air of dangerous goods. It should be given by a formal training course which takes place at a time when the person is not undertaking normal duties. The course may be by means of tuition or as a self-study program or a mixture of both of these. It should cover all the areas of dangerous goods relevant to the person receiving the training, although areas not likely to be relevant may be omitted (for instance, training in the transport of radioactive materials may be excluded where they will not be carried by the operator).

## 6. Training in Emergency Procedures.

- a. Except for crew members whose emergency procedures training is covered in subparagraphs 6 b or 6 c (as applicable) below:
  - i. Dealing with damaged or leaking packages; and
  - ii. Other actions in the event of ground emergencies arising from dangerous goods;
- b. For flight crew members:
  - i. Actions in the event of emergencies in flight occurring in the passenger cabin or in the cargo compartments; and
  - ii. The notification to Air Traffic Services should an in-flight emergency occur (See JCAR OPS 1.1215(e)).

- c. For crew members other than flight crew members:
  - i. Dealing with incidents arising from dangerous goods carried by passengers;  
or
  - ii. Dealing with damaged or leaking packages in flight.
- 7. Recurrent training should cover the areas relevant to initial Dangerous Goods training unless the responsibility of the individual has changed.
- 8. Test to verify understanding. It is necessary to have some means of establishing that a person has gained an understanding as a result of training; this is achieved by requiring the person to undertake a test. The complexity of the test, the manner of conducting it and the questions asked should be commensurate with the duties of the person being trained; and the test should demonstrate that the training has been adequate. If the test is completed satisfactorily a certificate should be issued confirming this.

### **AC OPS (AMC) 1.1225**

#### **Dangerous Goods Incident and Accident Reports**

See JCAR OPS 1.1225

Use of a standard form for the reporting of dangerous goods incidents and accidents would assist the Authorities and enable them to establish quickly the essential details of an occurrence. The following form has been developed for such use and its correct and full completion means that all the details required by Appendix 1 to JCAR OPS 1.1225 would have been covered. It may be sent to the relevant Authorities by any appropriate means including fax, mail, electronic mail, etc.



**DANGEROUS GOODS OCCURRENCE REPORT**

**DGOR NO:**

Using this form will meet the reporting requirements of JCAR OPS 1.1225 and JCAR OPS 3.1225. See the Notes on the reverse of this form. Those boxes where the heading is in italics need only be completed if applicable.

1. Operator:		2. Date of occurrence:		3. <i>Local time of occurrence:</i>	
4. <i>Flight date:</i>		5. <i>Flight no:</i>			
6. <i>Departure airport:</i>		7. <i>Destination airport:</i>			
8. <i>Aircraft type:</i>		9. <i>Aircraft registration:</i>			
10. Location of occurrence:		11. Origin of the goods:			
12. Description of the occurrence, including details of injury, damage, etc (if necessary continue on the reverse of this form):					
13. Proper shipping name (including the technical name):				14. UN/ID no (when known):	
15. Class/division (when known):	16. <i>Subsidiary risk(s):</i>	17. <i>Packing group:</i>	18. <i>Category (class 7 only):</i>		
19. <i>Type of packaging:</i>	20. <i>Packaging specification marking:</i>	21. <i>No of packages:</i>	22. <i>Quantity (or transport index, if applicable):</i>		
23. <i>Reference no of Air Waybill:</i>					
24. <i>Reference no of courier pouch, baggage tag, or passenger ticket:</i>					
25. Name and address of shipper, agent, passenger, etc:					
26. Other relevant information (including suspected cause, any action taken):					
27. Name and title of person making report:			28. Telephone no:		
29. Company:			30. <i>Reporters ref:</i>		
31. Address:			32. Signature:		
			33. Date:		

Description of the occurrence (continuation):

## NOTES

1. Any type of dangerous goods occurrence must be reported, irrespective of whether the dangerous goods are contained in cargo, mail or baggage.
2. A dangerous goods accident is an occurrence associated with and related to the transport of dangerous goods which results in fatal or serious injury to a person or major property damage. For this purpose serious injury is an injury which is sustained by a person in an accident and which: (a) requires hospitalization for more than 48 hours, commencing within 7 days from the date the injury was received; or (b) results in a fracture of any bones (except simple fractures of fingers, toes or nose); or (c) involves lacerations which cause severe hemorrhage, nerve, muscle or tendon damage; or (d) involves injury to any internal organ; or (e) involves second or third degree burns, or any burns affecting more than 5% of the body surface; or (f) involves verified exposure to infectious substances or injurious radiation. A dangerous goods accident may also be an aircraft accident; in which case the normal procedure for reporting of air accidents must be followed.

3. A dangerous goods incident is an occurrence, other than a dangerous goods accident, associated with and related to the transport of dangerous goods, not necessarily occurring on board an aircraft, which results in injury to a person, property damage, fire, breakage, spillage, leakage of fluid or radiation or other evidence that the integrity of the packaging has not been maintained. Any occurrence relating to the transport of dangerous goods which seriously jeopardizes the aircraft or its occupants is also deemed to constitute a dangerous goods incident.
4. This form should also be used to report any occasion when undeclared or miss declared dangerous goods are discovered in cargo, mail or unaccompanied baggage or when accompanied baggage contains dangerous goods which passengers or crew are not permitted to take on aircraft.
5. An initial report, which may be made by any means, must be dispatched within 72 hours of the occurrence, to the Authority of the State (a) of the operator; and (b) in which the incident occurred, unless exceptional circumstances prevent this. This occurrence report form, duly completed, must be sent as soon as possible, even if all the information is not available.
6. Copies of all relevant documents and any photographs should be attached to this report.
7. Any further information, or any information not included in the initial report, must be sent as soon as possible to authorities identified in 5.
8. Providing it is safe to do so, all dangerous goods, packaging's, documents, etc, relating to the occurrence must be retained until after the initial report has been sent to the Authorities identified in 5 and they have indicated whether or not these should continue to be retained.

## **AC S Security**

### **AC OPS 1.1240**

#### **Training programs**

See JCAR OPS 1.1240

Individual crew member knowledge and competence should be based on the relevant elements described in ICAO doc 9811, “Manual of the implementation of the Security provisions of annex 6” and ECAC DOC 30 part “Training for Cockpit and Cabin crew”.